



## Listing Constructional Data Report (CDR)

1.0 Reference and Address			
Report Number	18070260HKG-001	Original Issued: 10-Dec-2018	Revised: 13-Feb-2023
Standard(s)	Luminaires [UL 1598:2021 Ed.5+R:18Jun2021]		
	Luminaires [CSA C22.2#250.0:2021 Ed.5+U1]		
Applicant	Shenzhen goldsuno opto-electronic technology Co. Ltd.	Manufacturer	<b>Shenzhen goldsuno opto-electronic technology Co. Ltd.</b>
Address	4F & 5F, Building B, Nuofeng Technology Park, Yuzhang 5Rd, Da Shui Tian, LONGHUA DISTRICT, Shenzhen	Address	4F & 5F, Building B, Nuofeng Technology Park, Yuzhang 5Rd, Da Shui Tian, LONGHUA DISTRICT, Shenzhen
Country	China	Country	China
Contact	Chen Jun Long	Contact	Chen Jun Long
Phone	13902470589	Phone	13902470589
FAX	NA	FAX	NA
Email	cz@goldsuno.com	Email	cz@goldsuno.com

<b>2.0 Product Description</b>	
Product	LED recessed luminaire
Brand name	GOLDSUNO
Description	The products covered by this report is a type IC recessed luminaire provided with conduit opening and lead for supply connection. They were equipped with build-in LVLE/ non-isolated LED driver, suitable for Damp location use.
Models	<p>JXL-TZ04-T10W-CCT - or JXL-TZ06-T12W-CCT -; followed by 27 to 65.</p> <p>JXL-COB03-T07W-UDD, JXL-COB03-T10W-UDD, JXL-COB04-T10W-UDD, JXL-COF04-T10W-UDD, JXL-AF04-T10W-UDD, JXL-AF06-T15W-UDD, JXL-ZF03-T07W-UDD, JXL-ZF04-T12W-UDD, JXL-CA08-T25W-UDD, JXL-CF08-T25W-UDD, JXL-COB04-E15W-UDD, JXL-TE06-T25W-CCT, JXL-TE08-T25W-CCT, JXL-COB06-F25/18/15W-UDD, JXL-COB08-F25/18/15W-UDD, JXL-TE06-E25/18/15W-UDD, JXL-TE08-E25/18/15W-UDD, JXL-COB08-F36W-UDD or JXL-TE08-E36W-UDD; may be followed by -; may be followed by one to two numbers; may be followed by K; may be followed by W, WH, MW, B, BL, BC or BK.</p> <p>JXL-COB02-R08W-UDN, JXL-COB02-S08W-UDN, JXL-COB04-R12W-UDN, JXL-COB04-S12W-UDN, JXL-COB04-S15W-UDN, JXL-COB04-R15W-UDN, JXL-SMD04-G10W-UDN, JXL-COB04-G10W-UDN, JXL-COB04-G10W-CCT, JXL-SMD04-G10W-CCT, JXL-TE04-T12W-UDN, JXL-TEH04-T12W-UDN, JXL-TE06-G12W-UDN, JXL-TE06-T12W-UDN, JXL-TE08-T18W-UDN, JXL-TX05-T10W-UDN, JXL-TX10-T18W-UDN, JXL-TXH10-T18W-UDN, JXL-TZ04-T10W-UDN, JXL-TZ06-T12W-UDN, JXL-CA04-T10W-UDN, JXL-CA06-T12W-UDN, JXL-TZ04-R10W-CCT, JXL-TZ06-R12W-CCT, JXL-COB04-R12W-CCT, JXL-COB04-S12W-CCT, JXL-TXH03-T10W-CCT, JXL-TXH05-T18W-CCT, JXL-COB04-R15W-CCT, JXL-COB04-S15W-CCT, JXL-COB02-R08W-CCT, JXL-COB02-S08W-CCT, JXL-CA04-T10W-CCT, JXL-CA06-T12W-CCT, JXL-CM06-T12W-CCT, JXL-CM04-T10W-CCT, JXL-CF04-T10W-CCT or JXL-CF06-T12W-CCT; may be followed by -; may be followed by 27 to 65; may be followed by -; may be followed by S, SM, B or BF; may be followed by W, WH, MW, B, BL, BC, BK, WB, WHB, WBK, WBL or CM.</p> <p>JXL-TXH05-T10W-UDN may be followed by -; may be followed by 27 to 65; may be followed by -; may be followed by S, SM, B or BF; may be followed by W, WH, MW, B, BL, BC, BK, WB, WHB, WBK, WBL or CM; may be followed by -; may be followed by A.</p> <p>JXL-TZ04-T10W-5CCT, JXL-CM04-T10W-5CCT, JXL-TZ06-T12W-5CCT, JXL-CM06-T12W-5CCT, JXL-CA04-T10W-5CCT, JXL-CF04-T10W-5CCT, JXL-CA06-T12W-5CCT, JXL-CF06-T12W-5CCT, JXL-COB04-G12W-5CCT, JXL-TZ04-T10W-RGBCW, JXL-CA04-T10W-RGBCW, JXL-TZ06-T12W-RGBCW or JXL-CA06-T12W-RGBCW; may be followed by -; may be followed by 27 to 65; may be followed by W, WH, MW, B, BL, BC, BK, WB, WHB, WBK, WBL, CM or OB.</p> <p>JXL-TEH06-T18W-UDN may be followed by -; may be followed by 27 to 65; may be followed by W, WH, MW, B, BL, BC, BK, WB, WHB, WBK, WBL, CM or OB.</p> <p>JXL-COB02-R9W-5CCT, JXL-COB02-S9W-5CCT, JXL-COB04-R15W-5CCT, JXL-COB04-S15W-5CCT, JXL-COB04-R12W-5CCT, JXL-COB04-S12W-5CCT, JXL-COB06-R15W-5CCT, JXL-COB06-S15W-5CCT, JXL-TA08-T18W-5CCT, JXL-TF08-T18W-5CCT, JXL-TZ06-T15W-5CCT, JXL-CA06-T15W-5CCT, JXL-SMD04-G12W-5CCT, JXL-TXH05-T11W-5CCT, JXL-TXH10-T18W-5CCT, JXL-ZF03-T07W-5CCT, JXL-TZ03-T7W-5CCT, JXL-BK04-T10W-5CCT, JXL-BK06-T12W-5CCT or JXL-COB04-T10W-5CCT; may be followed by -; may be followed by 27 to 65; may be followed by W, WH, MW, B, BL, BC, BK, WB, WHB, WBK, WBL, CM or OB.</p>

**2.0 Product Description**

**Model Similarity** They are similar in electrical and mechanical construction. Differences among them are outlook and size, no. of LEDs, driver and ratings.

**Note:**

1. The number 27 to 65 or one to two numbers (represents as xx) denotes the CCT of LEDs.
- 1a. Suffix S, SM, B or BF denotes the different trim finish, for example, S or SM for Smooth Design; B or BF for Baffle design.
- 1b. Suffix W, WH, MW, B, BL, BC, BK, WB, WHB, WBK, WBL, CM or OB denotes finish color, for example, W or WH or MW for all white; B, BL, BC or BK for all black; WB, WHB, WBK or WBL for white with black, CM for Chrome, OB for oil brown.
3. LED driver model DM001A and DM001B with same schematic diagram and PCB layout, refer to Illustration 49 for the component difference table.
4. LED driver model TR120A, TR120B with same schematic diagram and PCB layout, refer to Illustration 86a for the component difference table.
5. Model JXL-TXH05-T10W-UDN with suffix A denotes equipped with driver TR-023A, without suffix A denotes equipped with driver TR120B.
6. LED driver model TR-053 and TR-054 with same schematic diagram and PCB layout, refer to Illustration 95a for the component difference table.

Model No.	LED driver	No. of LED	Dimensions of LED panel	Weight (kg)	Group
JXL-TZ04-T10W-CCT-xx	TR012	66	Ø122 X 11.5	0.41	--
JXL-TZ06-T12W-CCT-xx	TR012	78	Ø173 X 11.5	0.55	--
JXL-COB03-T07W-UDD-xx	TR017-A	1	Ø79 X 80	0.36	--
JXL-COB03-T10W-UDD-xx	TR017-A	1	Ø79 X 110	0.40	--
JXL-COB04-T10W-UDD-xx	TR017-A	1	Ø95 X 100	0.62	--
JXL-COF04-T10W-UDD-xx	TR017-A	1	95 X 95 X 100	0.66	--
JXL-ZF03-T07W-UDD-xx	TR-019	1	Ø85 X 48	0.39	--
JXL-CA08-T25W-UDD-xx	DM001A	84	Ø223 X 11.5	0.73	--
JXL-CF08-T25W-UDD-xx	DM001A	84	224 X 224 X 11.5	0.82	--
JXL-TE06-T25W-CCT-xx	TR018-B	120	Ø191 X 97	0.82	--
JXL-TE08-T25W-CCT-xx	TR018-B	120	Ø227 X 109	0.96	--
JXL-COB04-E15W-UDD-xx	DM001A	1	Ø130 X 74	0.56	
JXL-COB06-F25/18/15W-UDD-xx	DM001A	1	Ø191 X 97	0.82	--
JXL-COB08-F25/18/15W-UDD-xx	DM001A	1	Ø227 X 109	0.99	--
JXL-TE06-E25/18/15W-UDD-xx	DM001A	60	Ø191 X 97	0.82	--
JXL-TE08-E25/18/15W-UDD-xx	DM001A	60	Ø227 X 109	0.94	--
JXL-COB08-F36W-UDD-xx	DM001B	1	Ø227 X 109	0.99	--
JXL-TE08-E36W-UDD-xx	DM001B	84	Ø227 X 109	0.94	--

**2.0 Product Description**

<u>Model No.</u>	<u>LED driver, Alternative LED Driver</u>	<u>No. of LED</u>	<u>Dimensions of LED panel ( D X H or L X W X H) mm</u>	<u>Weight (kg)</u>	<u>Group</u>
JXL-COB02-R08W-UDN-XX	TR-019, TR120A	1	Ø80X65	0.24	1
JXL-COB02-S08W-UDN-XX	TR-019, TR120A	1	80X80X56	0.25	2
JXL-COB04-R12W-UDN-XX	TR-019, TR120B	1	Ø122X75	0.52	1
JXL-COB04-S12W-UDN-XX	TR-019, TR120B	1	122X122X70	0.54	2
JXL-COB04-S15W-UDN-XX	TR-018D	1	122X122X70	0.55	2
JXL-COB04-R15W-UDN-XX	TR-018D	1	Ø122X75	0.53	1
JXL-COB04-G10W-CCT	TR-012B	1	Ø122X56	0.60	4
JXL-SMD04-G10W-CCT	TR-012B	66	Ø122X56	0.58	3
JXL-TE04-T12W-UDN-XX	TR-023A	26	Ø122X56	0.43	5
JXL-TEH04-T12W-UDN-XX	TR-019	26	Ø122X56	0.43	5
JXL-TX05-T10W-UDN-XX	TR-023A	5	147x45x50	0.45	7
JXL-TX10-T18W-UDN-XX	TR-031A	10	280x45x50	0.64	7
JXL-TXH10-T18W-UDN-XX	TR-031A	10	280x45x50	0.64	8
JXL-TXH05-T10W-UDN-XX-A	TR-023A	5	147x45x50	0.45	8
JXL-TXH05-T10W-UDN-XX	TR120B				
JXL-TZ04-T10W-UDN-XX	TR-019, TR-319	33	Ø122x12	0.36	9
JXL-TZ06-T12W-UDN-XX	TR-019, TR-319	39	Ø173x11	0.48	9
JXL-CA04-T10W-UDN-XX	TR-019	33	Ø122x15	0.39	9
JXL-CA06-T12W-UDN-XX	TR-019	39	Ø173x15	0.50	9
JXL-TZ04-R10W-CCT	TR-012B	66	Ø122x12	0.37	9
JXL-TZ06-R12W-CCT	TR-012B	78	Ø173x11	0.50	9
JXL-COB04-R12W-CCT	TR-012B	1	Ø122X75	0.52	1
JXL-COB04-S12W-CCT	TR-012B	1	122X122X70	0.54	2
JXL-COB04-R15W-CCT	TR-030	1	Ø122X75	0.53	1

**2.0 Product Description**

<u>Model No.</u>	<u>LED driver, Alternative LED Driver</u>	<u>No. of LED</u>	<u>Dimensions of LED panel ( D X H or L X W X H) mm</u>	<u>Weight (kg)</u>	<u>Group</u>
JXL-COB04-S15W-CCT	TR-030	1	122X122X70	0.55	2
JXL-COB02-R08W-CCT	TR-012B	1	Ø80X65	0.35	1
JXL-COB02-S08W-CCT	TR-012B	1	80X80X56	0.37	2
JXL-CA04-T10W-CCT	TR-012B	66	Ø122x12	0.39	9
JXL-CA06-T12W-CCT	TR-012B	78	Ø173x15	0.50	9
JXL-CM06-T12W-CCT	TR-012B	78	170x170x12	0.52	11
JXL-CM04-T10W-CCT	TR-012B	66	120x120x12	0.39	11
JXL-CF04-T10W-CCT	TR-012B	66	120x120x14.5	0.41	11
JXL-CF06-T12W-CCT	TR-012B	78	170x170x15	0.56	11
JXL-TZ04-T10W-5CCT	TR-125 TR-063	66 or 44	Ø122X12	0.31	--
JXL-CM04-T10W-5CCT	TR-125 TR-063	66	120X120X12	0.33	--
JXL-TZ06-T12W-5CCT	TR-125 TR-063	78	Ø173X11	0.46	--
JXL-CM06-T12W-5CCT	TR-125 TR-063	78	170X170X12	0.46	--
JXL-CA04-T10W-5CCT	TR-125 TR-063	66 or 44	Ø122X12	0.31	--
JXL-CF04-T10W-5CCT	TR-125	66	120X120X14.5	0.35	--
JXL-CA06-T12W-5CCT	TR-125 TR-063	78	Ø173X15	0.46	--
JXL-CF06-T12W-5CCT	TR-125	78	170X170X12	0.51	--
JXL-COB04-G12W-5CCT	TR-125	1	Ø122X56	0.55	--
JXL-TZ04-T10W-RGBCW	TR-053 TR-054B	72	Ø122X12	0.37	--
JXL-CA04-T10W-RGBCW	TR-053	72	Ø122X12	0.37	--
JXL-TZ06-T12W-RGBCW	TR-054 TR-054B	96	Ø173X11	0.53	--
JXL-CA06-T12W-RGBCW	TR-054	96	Ø173X15	0.53	--
JXL-TEH06-T18W-UDN-XX	TR-018D	54	Ø190 X 75	0.78	--

2.0 Product Description						
JXL-COB02-R9W-5CCT	TR-071	1	∅80X65	0.36	--	
JXL-COB02-S9W-5CCT	TR-071	1	80X80X56	0.38	--	
JXL-COB04-R15W-5CCT	TR-062	1	∅122X75	0.53	--	
JXL-COB04-S15W-5CCT	TR-062	1	122X122X70	0.55	--	
JXL-COB04-R12W-5CCT	TR-063	1	∅122X75	0.53	--	
JXL-COB04-S12W-5CCT	TR-063	1	122X122X70	0.55	--	
JXL-COB06-R15W-5CCT	TR-062	1	∅178X80	0.66	--	
JXL-COB06-S15W-5CCT	TR-062	1	172X172X80	0.66	--	
JXL-TA08-T18W-5CCT	TR-062	108	∅223X11.5	0.65	--	
JXL-TF08-T18W-5CCT	TR-062	108	224X224X11.5	0.75	--	
JXL-TZ06-T15W-5CCT	TR-062	90	∅173X11	0.46	--	
JXL-CA06-T15W-5CCT	TR-062	90	∅173X15	0.46	--	
JXL-SMD04-G12W-5CCT	TR-063	24	∅95X100	0.63	--	
JXL-TXH05-T11W-5CCT	TR-063	10	147x45x50	0.45	--	
JXL-TXH10-T18W-5CCT	TR-062	20	280x45x50	0.64	--	
JXL-ZF03-T07W-5CCT	TR-071	1	∅85X48	0.39	--	
JXL-TZ03-T7W-5CCT	TR-071	32	∅85X11.5	0.29	--	
JXL-BK04-T10W-5CCT	TR-063	66	∅122x12	0.39	--	
JXL-BK06-T12W-5CCT	TR-063	78	∅173x15	0.50	--	
JXL-COB04-T10W-5CCT-XX	TR-071	1	∅95X100	0.28	--	

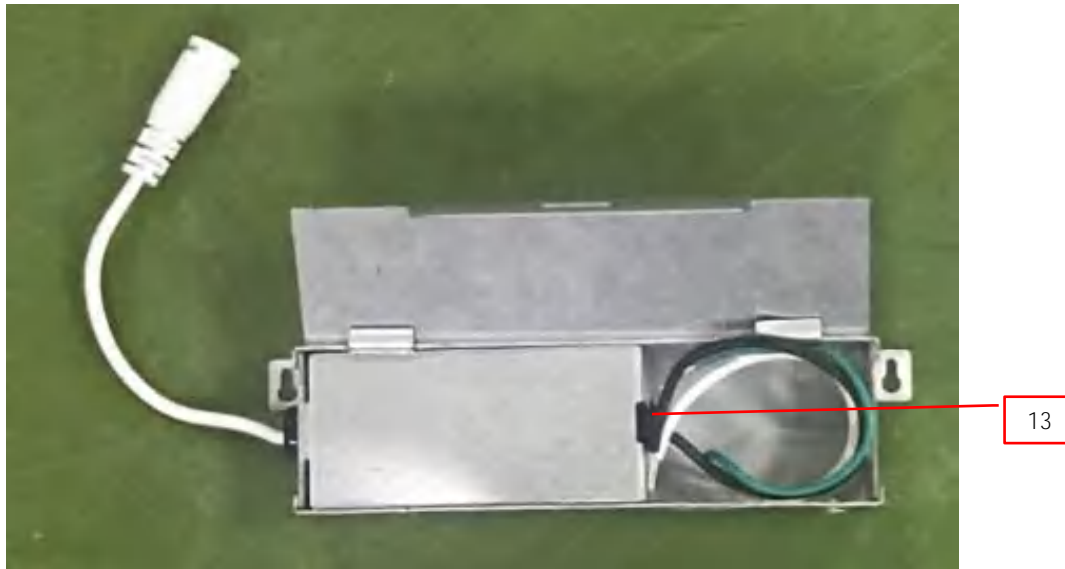
<b>2.0 Product Description</b>				
Ratings	<u>Model No.</u>	<u>Voltage (V) and frequency (Hz)</u>	<u>Wattage (W)</u>	<u>Dimmable or not (Y/N)</u>
	JXL-TZ04-T10W-CCT-xx	120V, 60Hz	10	Y
	JXL-TZ06-T12W-CCT-xx	120V, 60Hz	12	Y
	JXL-COB03-T07W-UDD-xx	120V, 60Hz	7	Y
	JXL-COB03-T10W-UDD-xx	120V, 60Hz	10	Y
	JXL-COB04-T10W-UDD-xx	120V, 60Hz	10	Y
	JXL-COF04-T10W-UDD-xx	120V, 60Hz	10	Y
	JXL-ZF03-T07W-UDD-xx	120V, 60Hz	7	Y
	JXL-CA08-T25W-UDD-xx	100-277V, 50-60Hz	25	Y
	JXL-CF08-T25W-UDD-xx	100-277V, 50-60Hz	25	Y
	JXL-TE06-T25W-CCT -xx	100-277V, 50-60Hz	25	Dimmable at 100-130V
	JXL-TE08-T25W-CCT -xx	100-277V, 50-60Hz	25	Dimmable at 100-130V
	JXL-COB04-E15W-UDD-xx	100-277V, 50-60Hz	15	Y
	JXL-COB06-F25/18/15W-UDD-xx	100-277V, 50-60Hz	Max. 25	Y
	JXL-COB08-F25/18/15W-UDD-xx	100-277V, 50-60Hz	Max. 25	Y
	JXL-TE06-E25/18/15W-UDD-xx	100-277V, 50-60Hz	Max. 25	Y
	JXL-TE08-E25/18/15W-UDD-xx	100-277V, 50-60Hz	Max. 25	Y
	JXL-COB08-F36W-UDD-xx	100-277V, 50-60Hz	36	Y
	JXL-TE08-E36W-UDD-xx	100-277V, 50-60Hz	36	Y
	JXL-COB02-R08W-UDN-XX	120V, 60Hz	8	Y
JXL-COB02-S08W-UDN-XX	120V, 60Hz	8	Y	

2.0 Product Description				
JXL-COB04-R12W-UDN-XX	120V, 60Hz	12	Y	
JXL-COB04-S12W-UDN-XX	120V, 60Hz	12	Y	
JXL-COB04-S15W-UDN-XX	100-277V, 50-60Hz	15	Y	
JXL-COB04-R15W-UDN-XX	100-277V, 50-60Hz	15	Y	
JXL-COB04-G10W-CCT	120V, 60Hz	10	Y	
JXL-SMD04-G10W-CCT	120V, 60Hz	10	Y	
JXL-TE04-T12W-UDN-XX	100-277V, 50-60Hz	12	Y	
JXL-TEH04-T12W-UDN-XX	120V, 60Hz	12	Y	
JXL-TX05-T10W-UDN-XX	100-277V, 50-60Hz	10	Y	
JXL-TX10-T18W-UDN-XX	100-277V, 50-60Hz	18	Y	
JXL-TXH10-T18W-UDN-XX	100-277V, 50-60Hz	18	Y	
JXL-TXH05-T10W-UDN-XX-A	100-277V, 50-60Hz	10	Y	
JXL-TXH05-T10W-UDN-XX	120V, 60Hz			
JXL-TZ04-T10W-UDN-XX	120V, 60Hz	10	Y	
JXL-TZ06-T12W-UDN-XX	120V, 60Hz	12	Y	
JXL-CA04-T10W-UDN-XX	120V, 60Hz	10	Y	
JXL-CA06-T12W-UDN-XX	120V, 60Hz	12	Y	
JXL-TZ04-R10W-CCT	120V, 60Hz	10	Y	
JXL-TZ06-R12W-CCT	120V, 60Hz	12	Y	
JXL-COB04-R12W-CCT	120V, 60Hz	12	Y	
JXL-COB04-S12W-CCT	120V, 60Hz	12	Y	
JXL-COB04-R15W-CCT	120V, 60Hz	15	Y	
JXL-COB04-S15W-CCT	120V, 60Hz	15	Y	
JXL-COB02-R08W-CCT	120V, 60Hz	8	Y	
JXL-COB02-S08W-CCT	120V, 60Hz	8	Y	
JXL-CA04-T10W-CCT	120V, 60Hz	10	Y	
JXL-CA06-T12W-CCT	120V, 60Hz	12	Y	
JXL-CM06-T12W-CCT	120V, 60Hz	12	Y	
JXL-CM04-T10W-CCT	120V, 60Hz	10	Y	
JXL-CF04-T10W-CCT	120V, 60Hz	10	Y	
JXL-CF06-T12W-CCT	120V, 60Hz	12	Y	

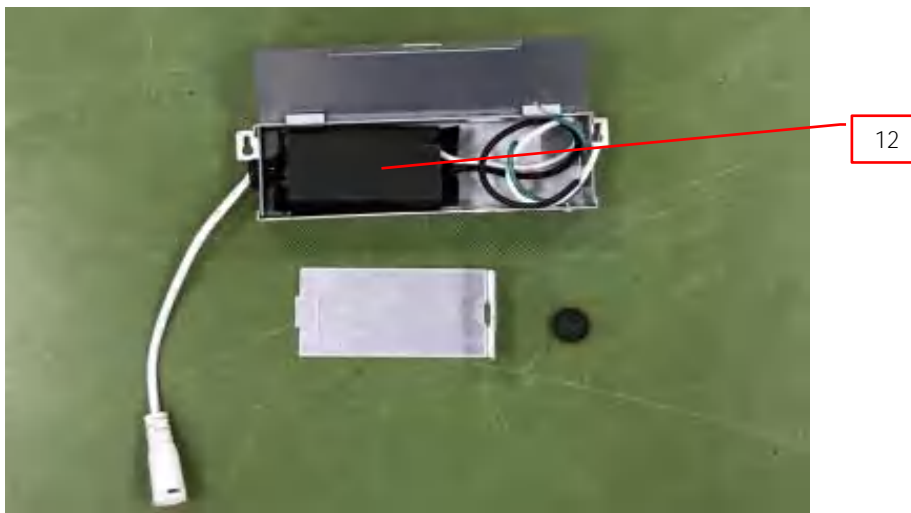
2.0 Product Description				
JXL-TZ04-T10W-5CCT	120V, 60Hz	10		Y
JXL-CM04-T10W-5CCT	120V, 60Hz	10		Y
JXL-TZ06-T12W-5CCT	120V, 60Hz	12		Y
JXL-CM06-T12W-5CCT	120V, 60Hz	12		Y
JXL-CA04-T10W-5CCT	120V, 60Hz	10		Y
JXL-CF04-T10W-5CCT	120V, 60Hz	10		Y
JXL-CA06-T12W-5CCT	120V, 60Hz	12		Y
JXL-CF06-T12W-5CCT	120V, 60Hz	12		Y
JXL-COB04-G12W-5CCT	120V, 60Hz	12		Y
JXL-TZ04-T10W-RGBCW	120V, 60Hz	10		N
JXL-CA04-T10W-RGBCW	120V, 60Hz	10		N
JXL-TZ06-T12W-RGBCW	120V, 60Hz	12		N
JXL-CA06-T12W-RGBCW	120V, 60Hz	12		N
JXL-TEH06-T18W-UDN-XX	100-277V, 50-60Hz	18		Y
JXL-COB02-R9W-5CCT	120V, 60Hz	9		Y
JXL-COB02-S9W-5CCT	120V, 60Hz	9		Y
JXL-COB04-R15W-5CCT	120V, 60Hz	15		Y
JXL-COB04-S15W-5CCT	120V, 60Hz	15		Y
JXL-COB04-R12W-5CCT	120V, 60Hz	12		Y
JXL-COB04-S12W-5CCT	120V, 60Hz	12		Y
JXL-COB06-R15W-5CCT	120V, 60Hz	15		Y
JXL-COB06-S15W-5CCT	120V, 60Hz	15		Y
JXL-TA08-T18W-5CCT	120V, 60Hz	18		Y
JXL-TF08-T18W-5CCT	120V, 60Hz	18		Y
JXL-TZ06-T15W-5CCT	120V, 60Hz	15		Y
JXL-CA06-T15W-5CCT	120V, 60Hz	15		Y
JXL-SMD04-G12W-5CCT	120V, 60Hz	12		Y
JXL-TXH05-T11W-5CCT	120V, 60Hz	11		Y
JXL-TXH10-T18W-5CCT	120V, 60Hz	18		Y
JXL-ZF03-T07W-5CCT	120V, 60Hz	7		Y
JXL-TZ03-T7W-5CCT	120V, 60Hz	7		Y
JXL-BK04-T10W-5CCT	120V, 60Hz	10		Y
JXL-BK06-T12W-5CCT	120V, 60Hz	12		Y
JXL-COB04-T10W-5CCT-XX	120V, 60Hz	10		Y
Other Ratings	NA			

### 3.0 Product Photographs

**Photo 11** - Internal view of junction box for model JXL-COB03-T07W-UDD-xx, JXL-COB03-T10W-UDD-xx, JXL-COB04-T10W-UDD-xx, JXL-COF04-T10W-UDD-xx, JXL-ZF03-T07W-UDD-xx

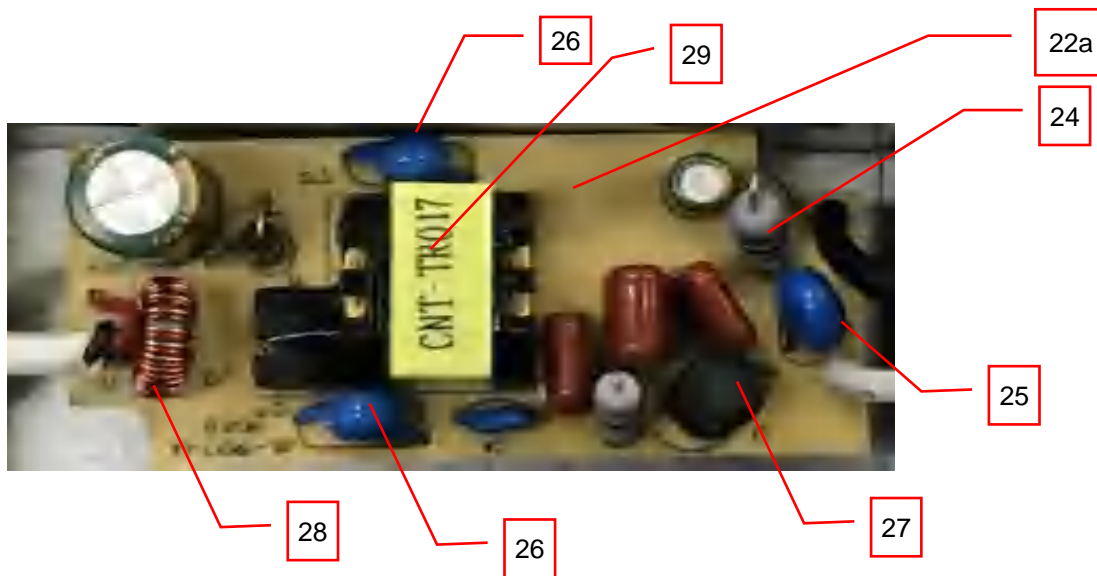


**Photo 11a** - Internal view of junction box for model JXL-COB03-T07W-UDD-xx, JXL-COB03-T10W-UDD-xx, JXL-COB04-T10W-UDD-xx, JXL-COF04-T10W-UDD-xx, JXL-ZF03-T07W-UDD-xx



### 3.0 Product Photographs

**Photo 18** - Front view of driver PCB of models JXL-COB03-T07W-UDD-xx, JXL-COB03-T10W-UDD-xx, JXL-COB04-T10W-UDD-xx, JXL-COF04-T10W-UDD-xx

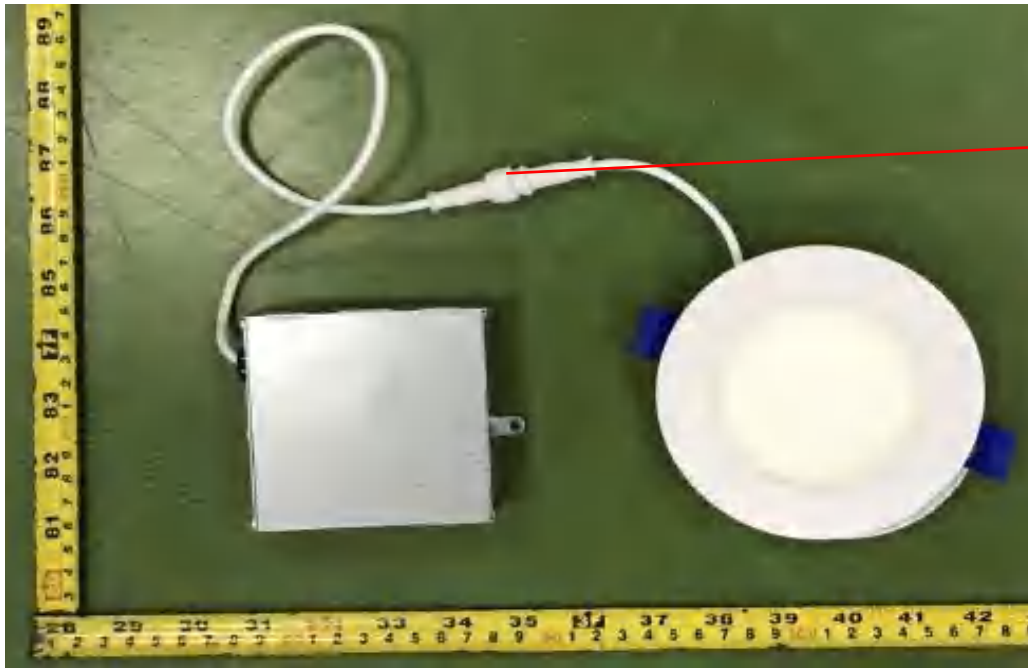


**Photo 19** - Rear view of driver PCB of models JXL-COB03-T07W-UDD-xx, JXL-COB03-T10W-UDD-xx, JXL-COB04-T10W-UDD-xx, JXL-COF04-T10W-UDD-xx



**3.0 Product Photographs**

**Photo 22** - External view of JXL-TZ04-T10W-CCT-xx



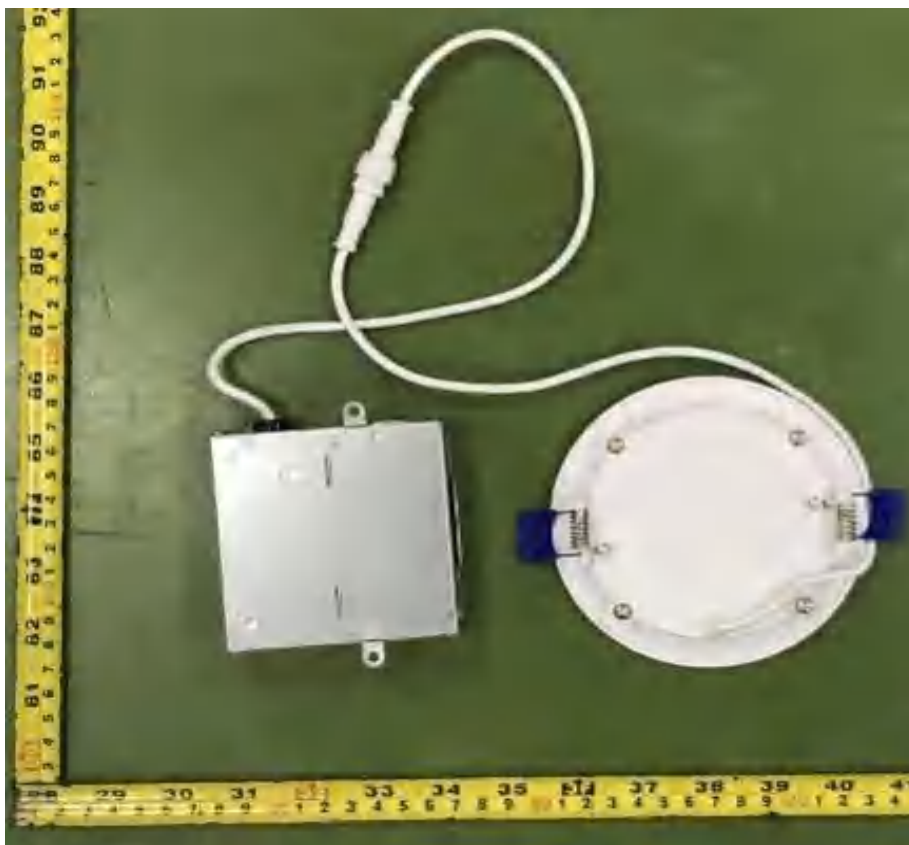
18

**Photo 22a** - External view of JXL-TZ06-T12W-CCT-xx



### 3.0 Product Photographs

**Photo 23** - Back view of JXL-TZ04-T10W-CCT-xx, it also represent model JXL-TZ06-T12W-CCT-xx

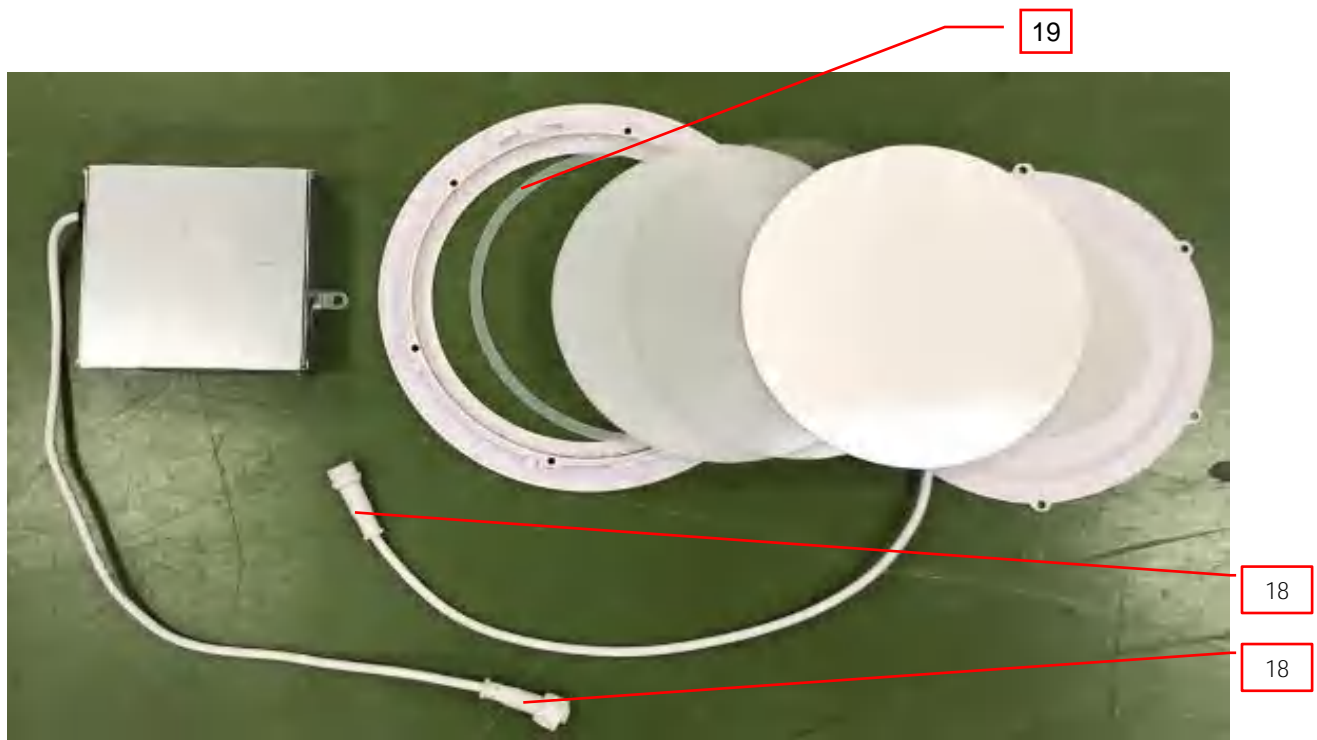


**Photo 24** - Internal view of JXL-TZ04-T10W-CCT-xx and JXL-TZ06-T12W-CCT-xx



**3.0 Product Photographs**

**Photo 25** - Internal view of JXL-TZ04-T10W-CCT-xx, it also represent model JXL-TZ06-T12W-CCT-xx



**Photo 26** - Internal view of JXL-TZ04-T10W-CCT-xx, it also represent model JXL-TZ06-T12W-CCT-xx

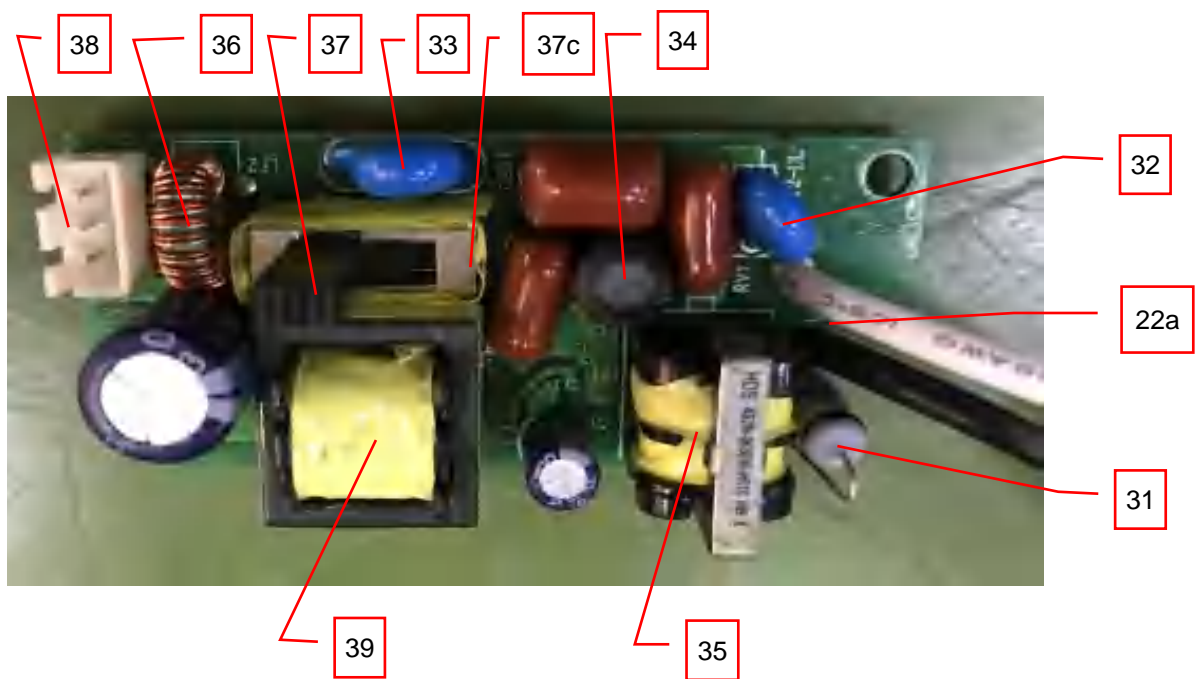


**3.0 Product Photographs**

**Photo 27** - Internal view of JXL-TZ04-T10W-CCT-xx and JXL-TZ06-T12W-CCT-xx



**Photo 28** - Front view of driver PCB of models JXL-TZ04-T10W-CCT-xx and JXL-TZ06-T12W-CCT-xx



**3.0 Product Photographs**

**Photo 29** - Rear View of driver PCB of models JXL-TZ04-T10W-CCT-xx and JXL-TZ06-T12W-CCT-xx



**Photo 39** - External view of JXL-COB03-T07W-UDD-xx

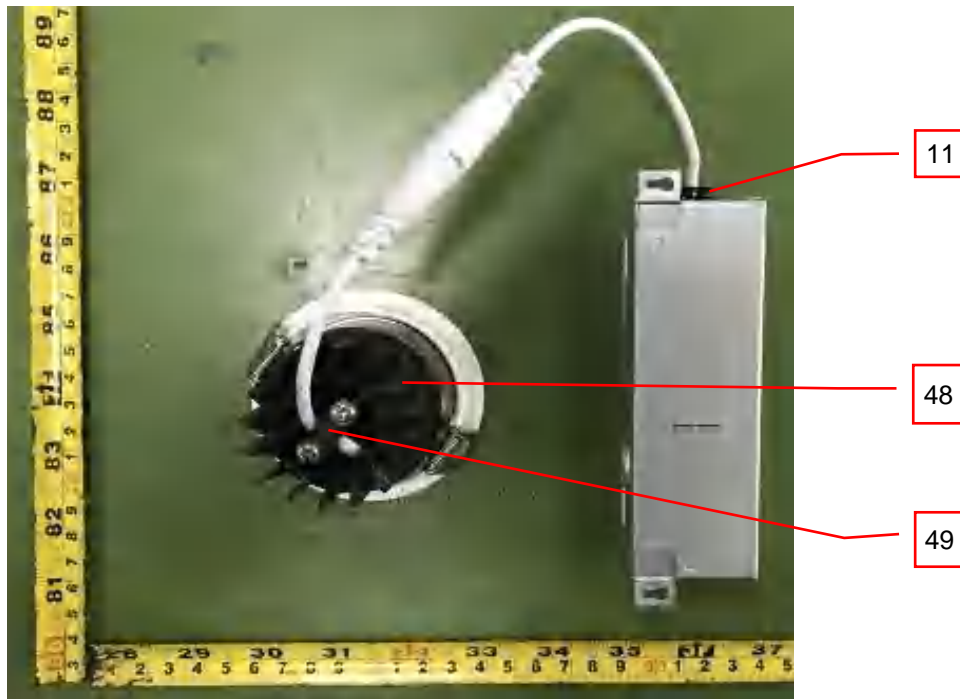


**3.0 Product Photographs**

**Photo 39a** - External view of alternative trim of model JXL-COB03-T07W-UDD-xx, JXL-COB03-T10W-UDD-xx

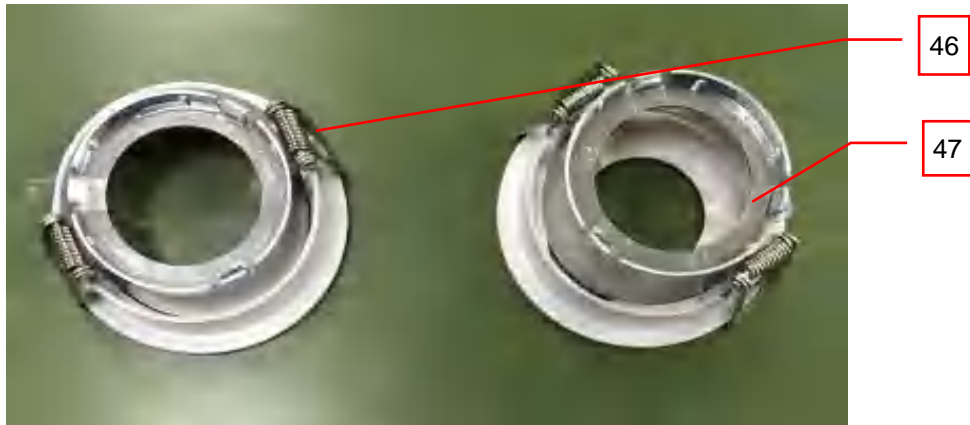


**Photo 40** - Back view of JXL-COB03-T07W-UDD-xx



**3.0 Product Photographs**

**Photo 40a** - Back view of alternative trim of model JXL-COB03-T07W-UDD-xx, JXL-COB03-T10W-UDD-xx



**Photo 41** - Internal view of JXL-COB03-T07W-UDD-xx



**3.0 Product Photographs**

**Photo 42** - Internal view of JXL-COB03-T07W-UDD-xx

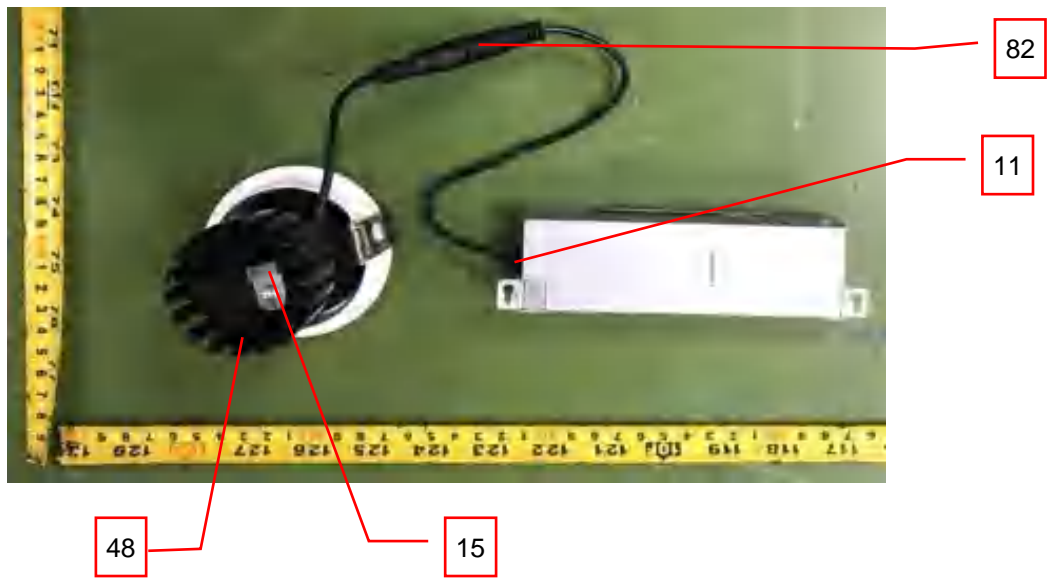


**Photo 43** - External view of JXL-COB03-T10W-UDD-xx



**3.0 Product Photographs**

**Photo 44** - Back view of JXL-COB03-T10W-UDD-xx

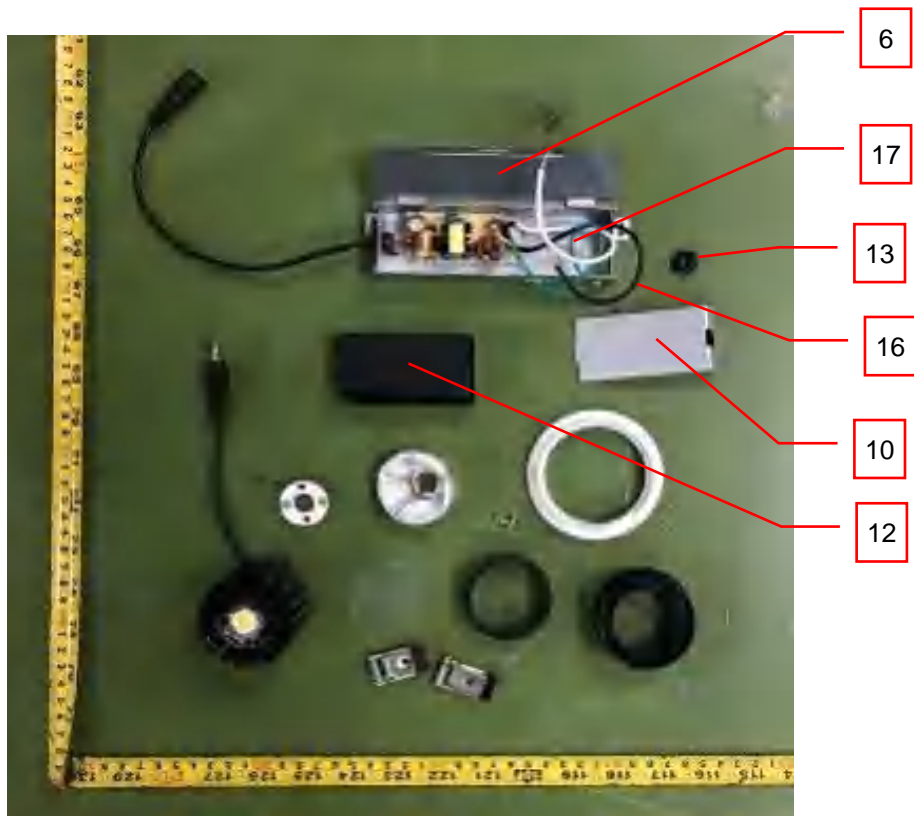


**Photo 45** - Internal view of JXL-COB03-T10W-UDD-xx, it also represent model JXL-COB04-T10W-UDD-xx, JXL-COF04-T10W-UDD-xx

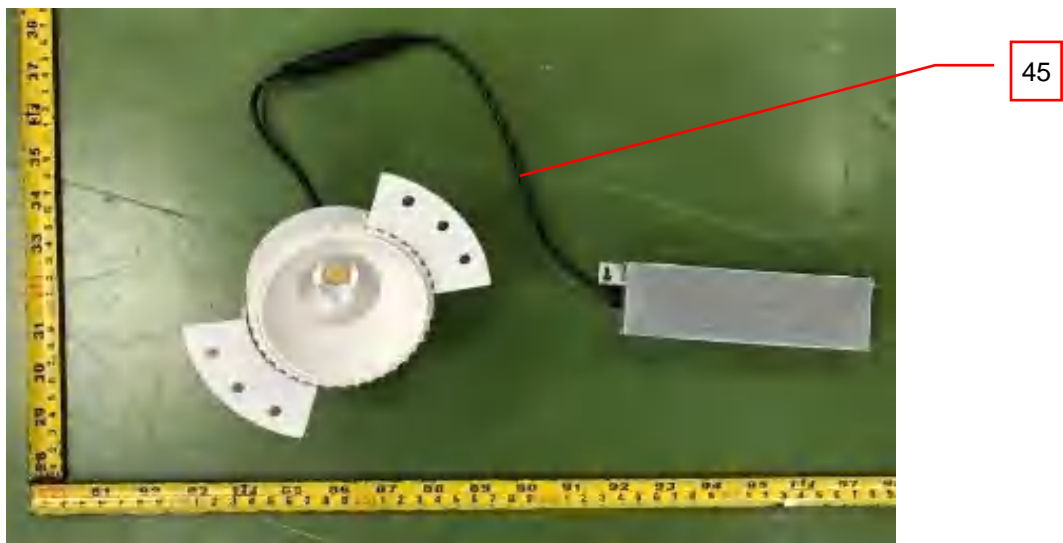


**3.0 Product Photographs**

**Photo 46** - Internal view of JXL-COB03-T10W-UDD-xx

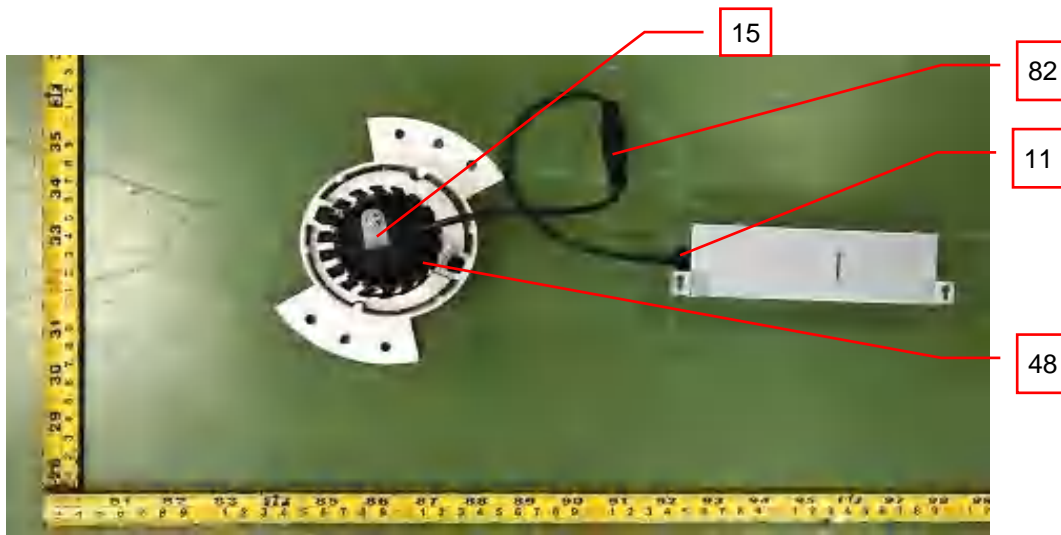


**Photo 54** - External view of JXL-COB04-T10W-UDD-xx

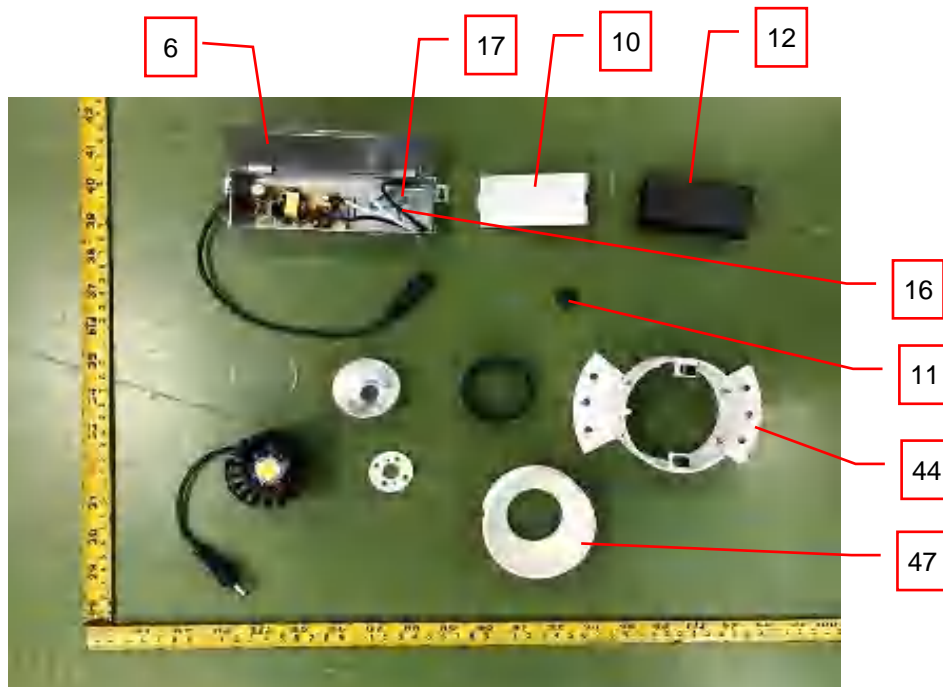


**3.0 Product Photographs**

**Photo 55 - Back view of JXL-COB04-T10-UDD-xx**

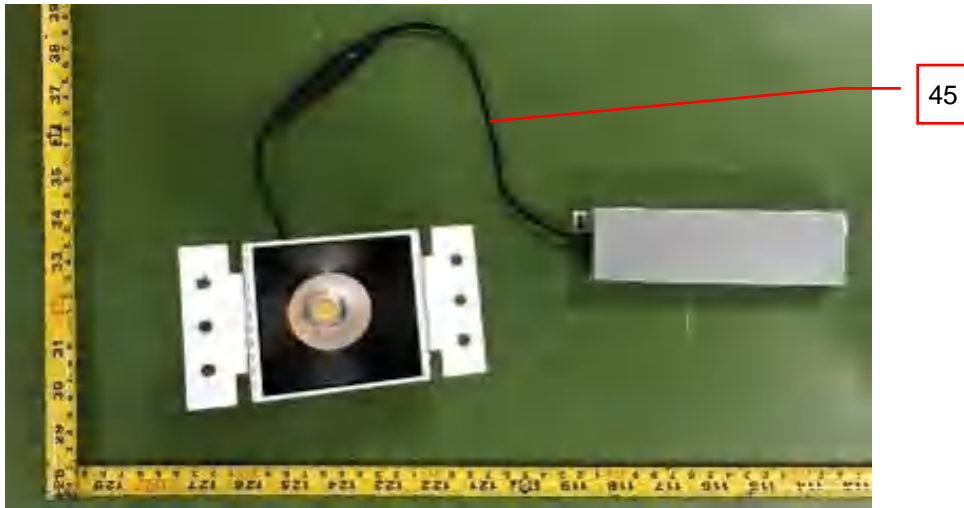


**Photo 56 - Internal view of JXL-COB04-T10W-UDD-xx**

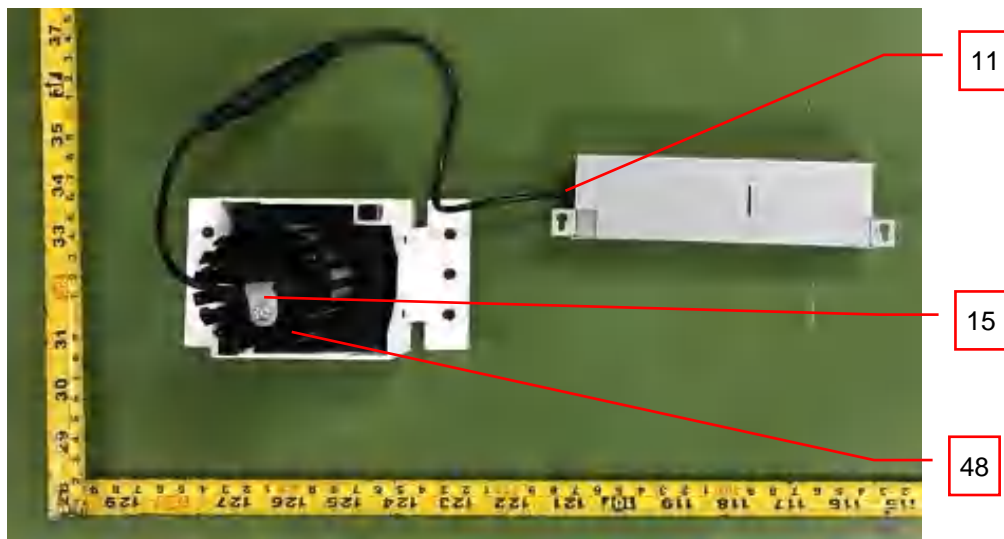


**3.0 Product Photographs**

**Photo 57** - External view of JXL-COF04-T10W-UDD-xx

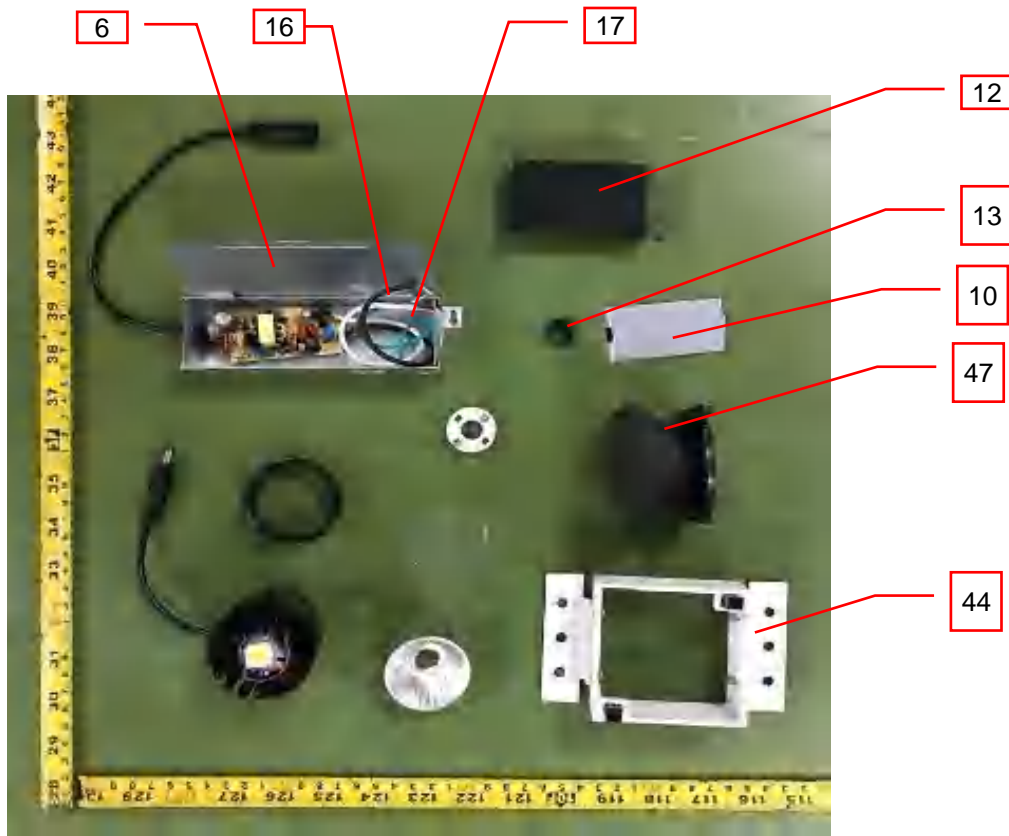


**Photo 58** - Back view of JXL-COF04-T10W-UDD-xx



**3.0 Product Photographs**

**Photo 59** - Internal view of JXL-COF04-T10W-UDD-xx

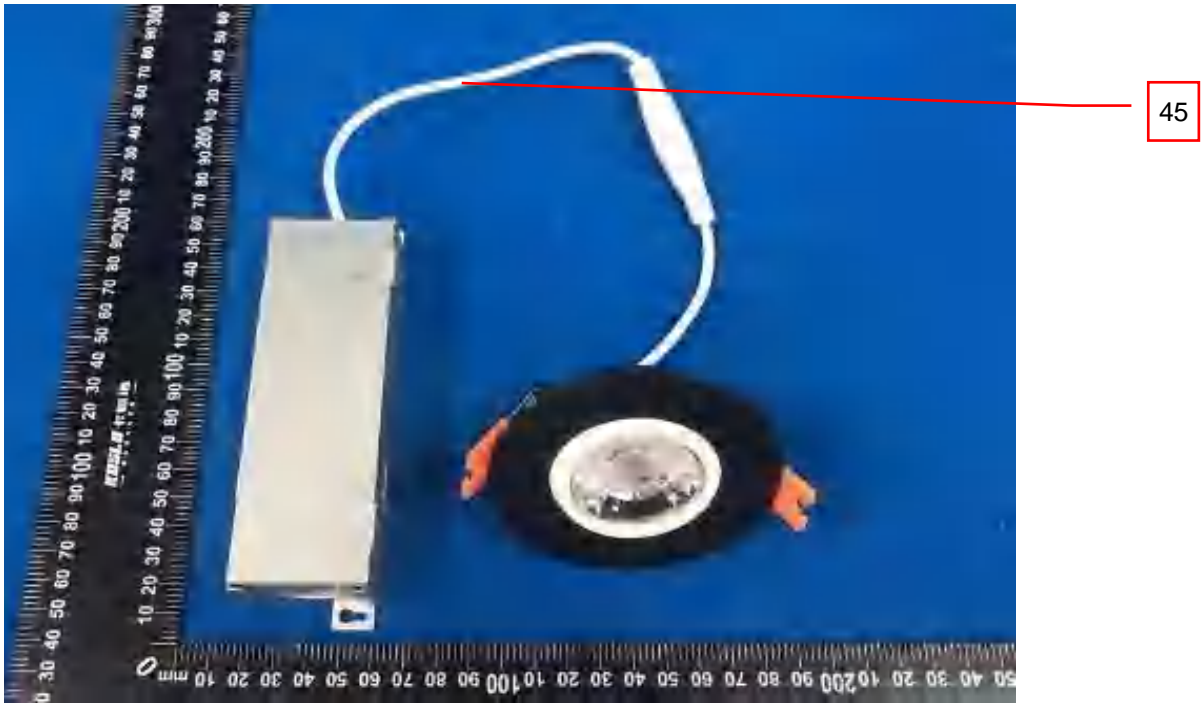


**Photo 95** - External view of JXL-ZF03-T07W-UDD-xx

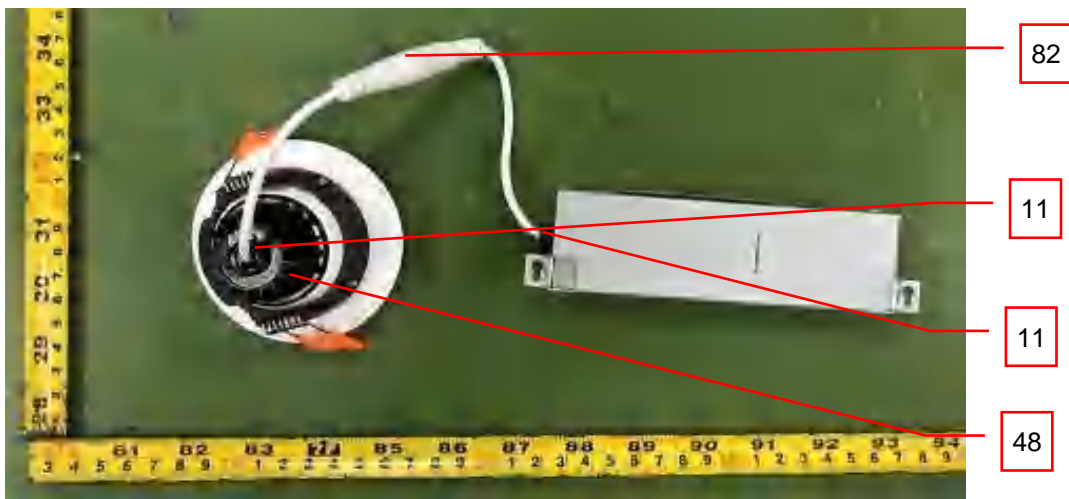


**3.0 Product Photographs**

**Photo 95a** - Alternative external view of JXL-ZF03-T07W-UDD-xx

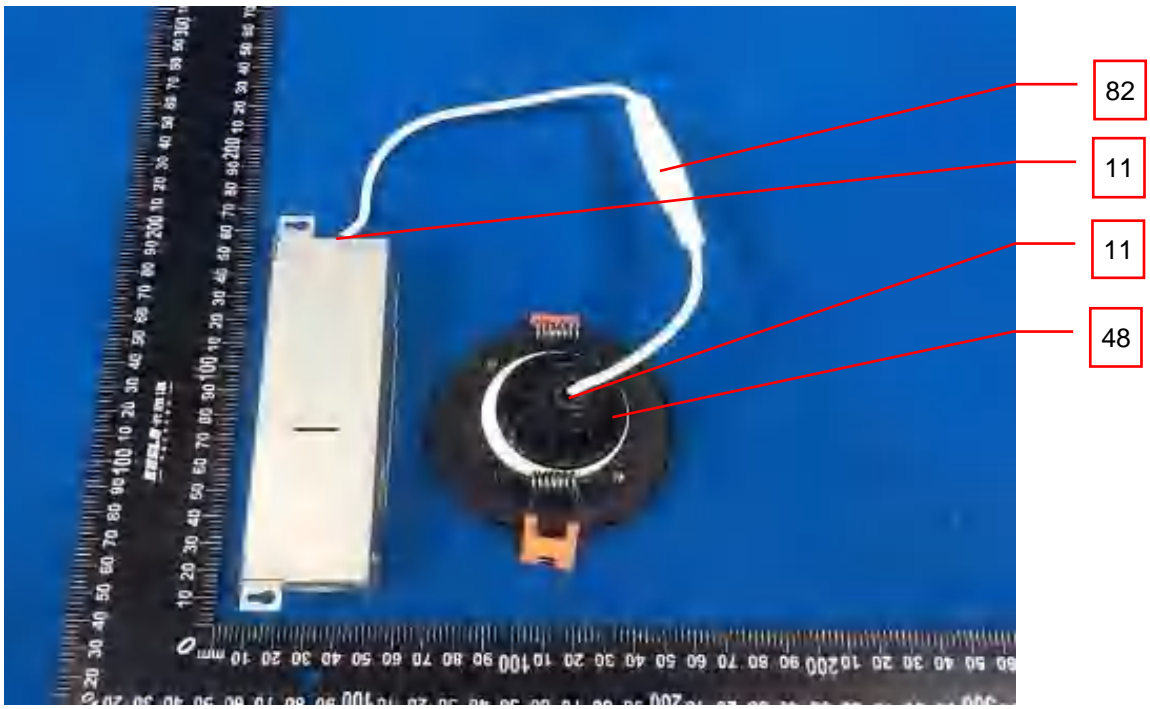


**Photo 96** - Back view of JXL-ZF03-T07W-UDD-xx

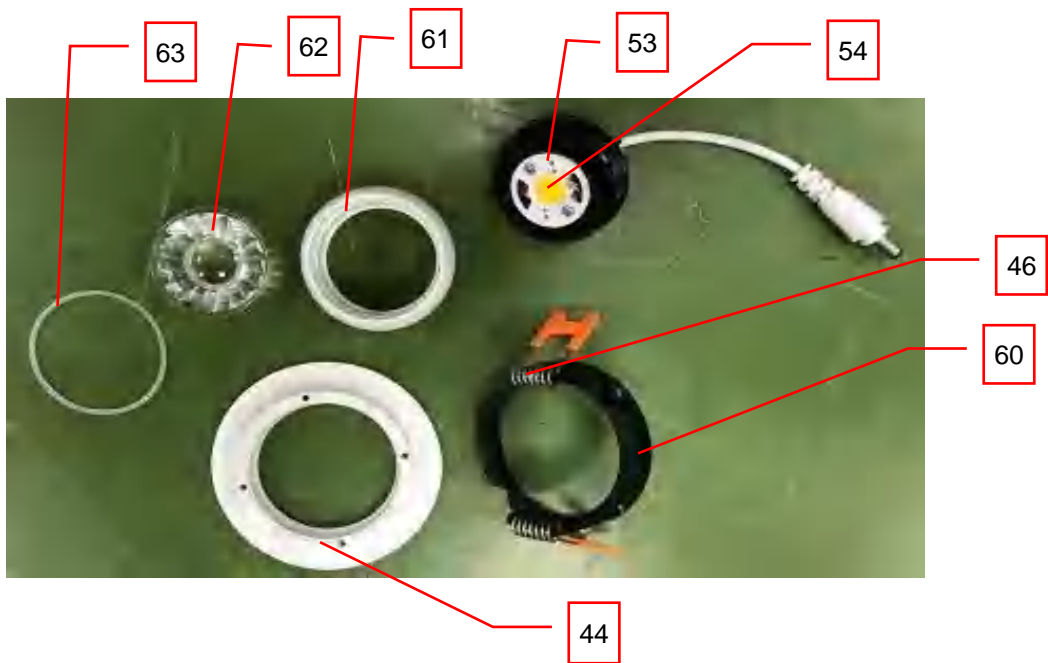


**3.0 Product Photographs**

**Photo 96a** - Alternative back view of JXL-ZF03-T07W-UDD-xx



**Photo 97** - Internal view of JXL-ZF03-T07W-UDD-xx

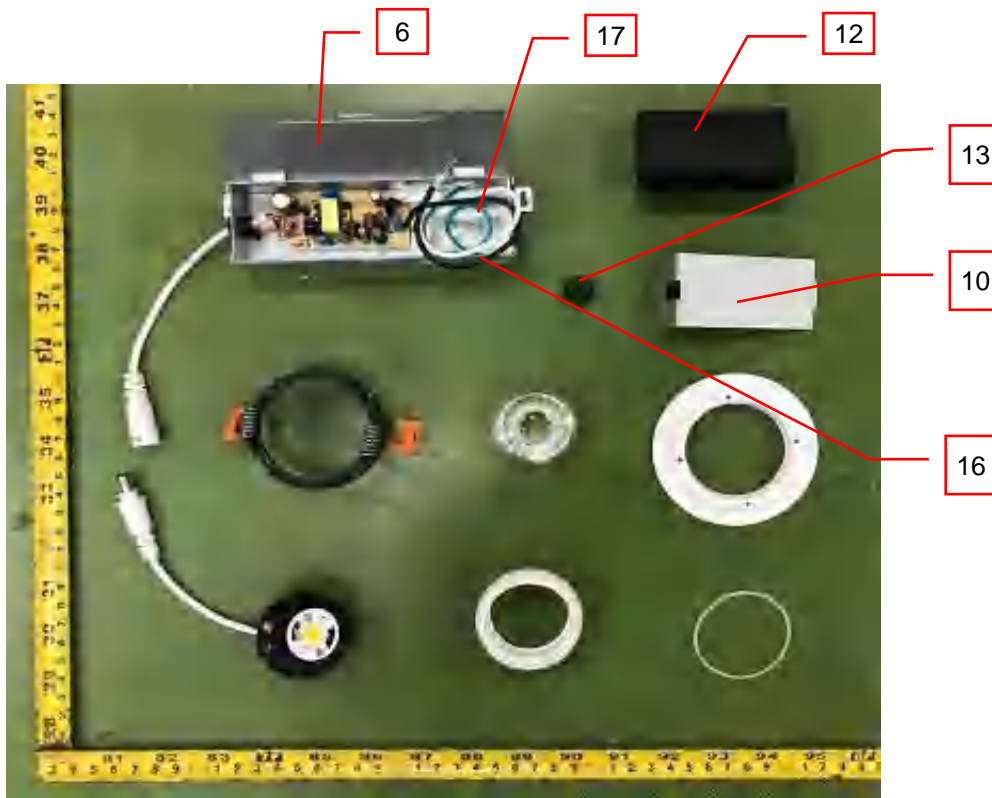


**3.0 Product Photographs**

**Photo 97a** - External view of alternative trim of model JXL-ZF03-T07W-UDD-xx

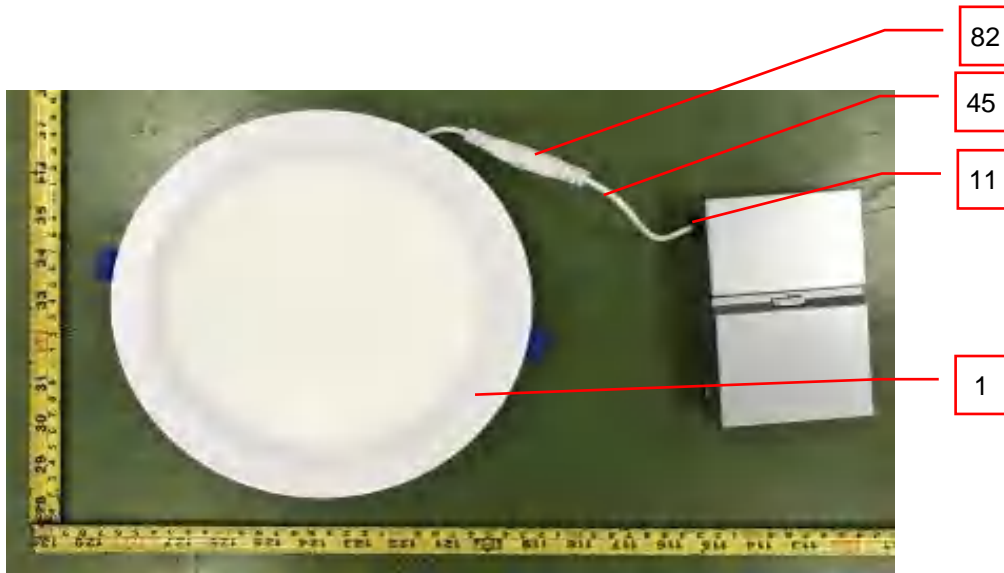


**Photo 98** - Internal view of JXL-ZF03-T07W-UDD-xx

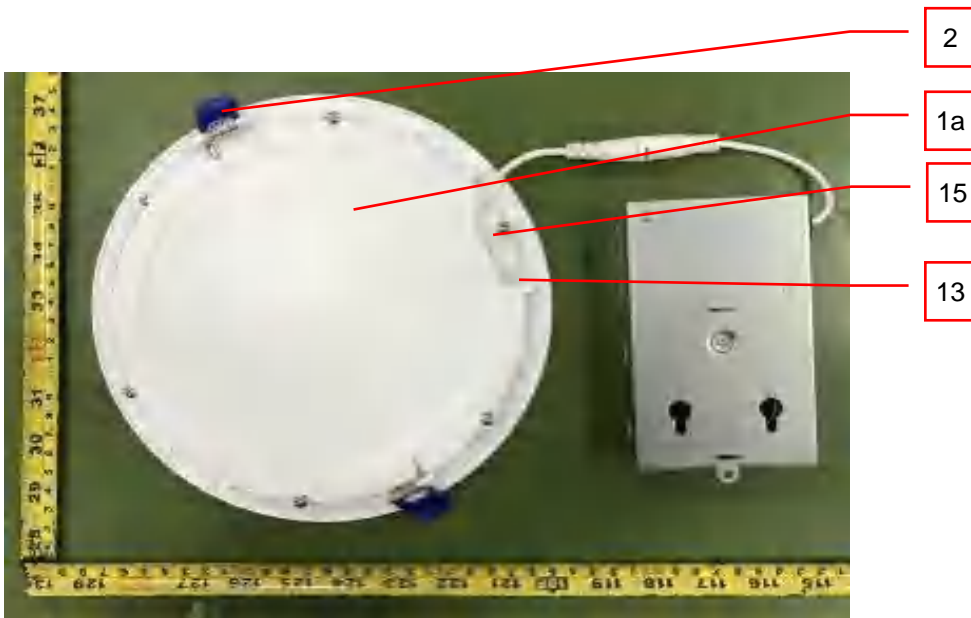


**3.0 Product Photographs**

**Photo 103** - External view of JXL-CA08-T25W-UDD-xx

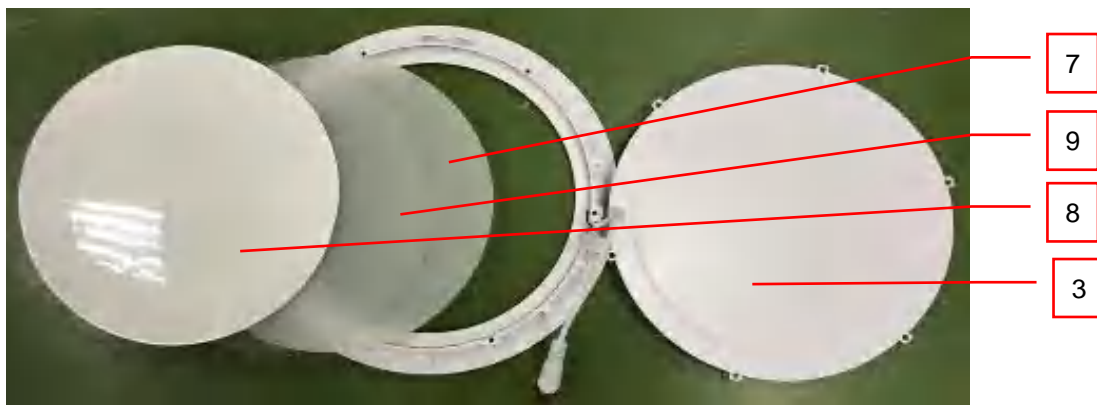


**Photo 104** - Back view of JXL-CA08-T25W-UDD-xx



### 3.0 Product Photographs

**Photo 105** - Internal view of JXL-CA08-T25W-UDD-xx

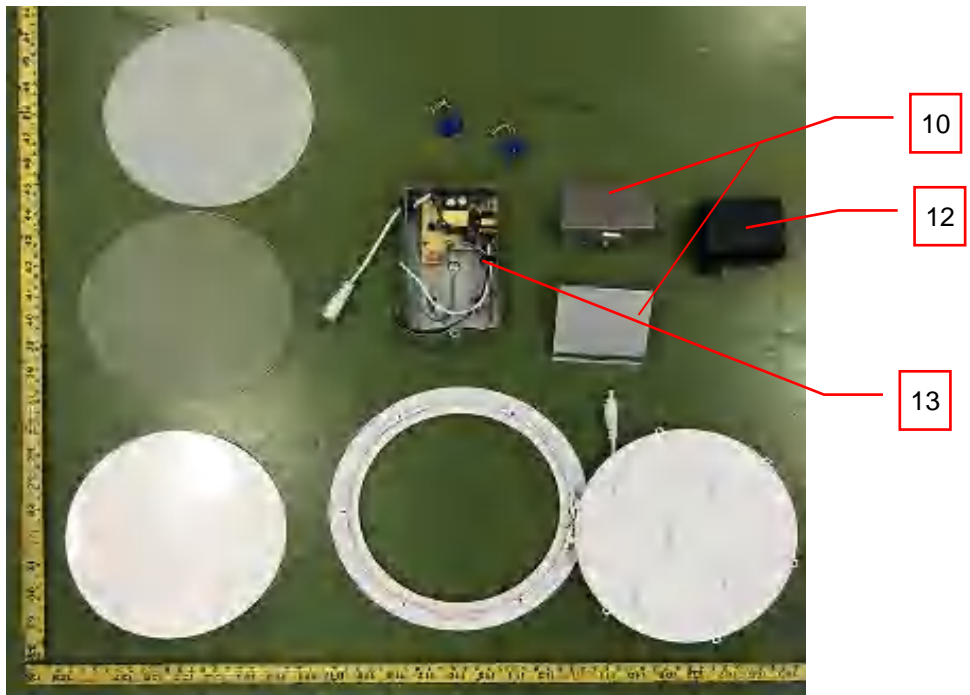


**Photo 106** - Internal view of JXL-CA08-T25W-UDD-xx

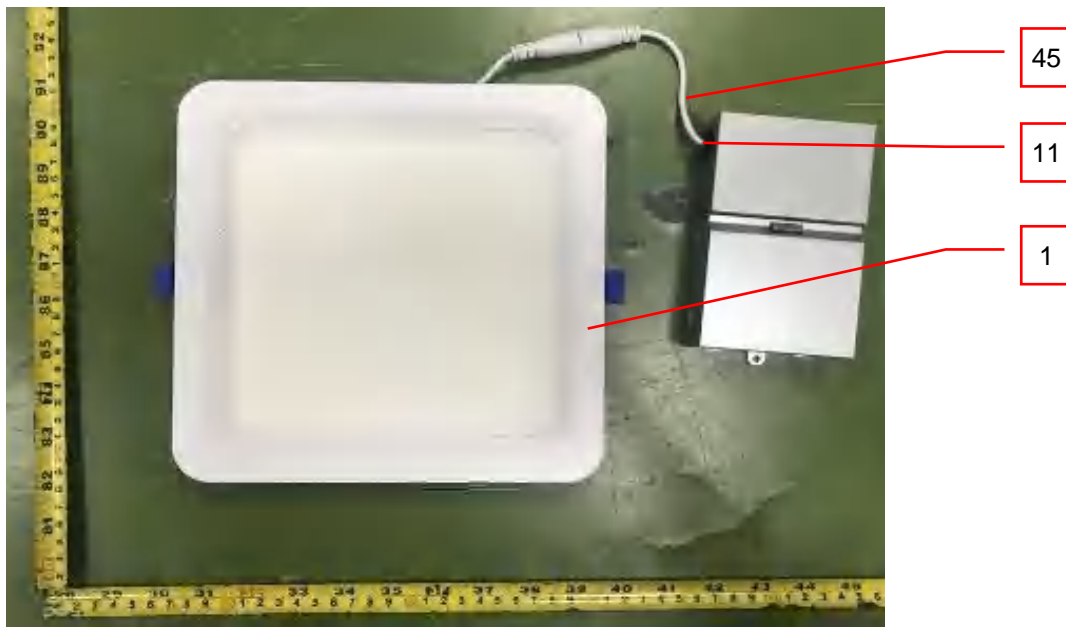


**3.0 Product Photographs**

**Photo 107** - Internal view of JXL-CA08-T25W-UDD-xx

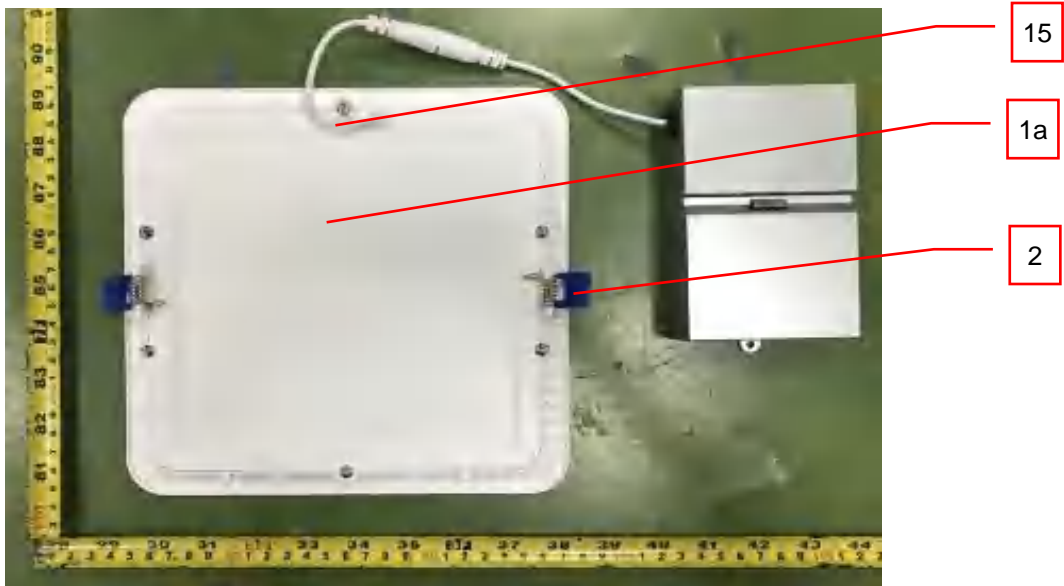


**Photo 108** - External view of JXL-CF08-T25W-UDD-xx

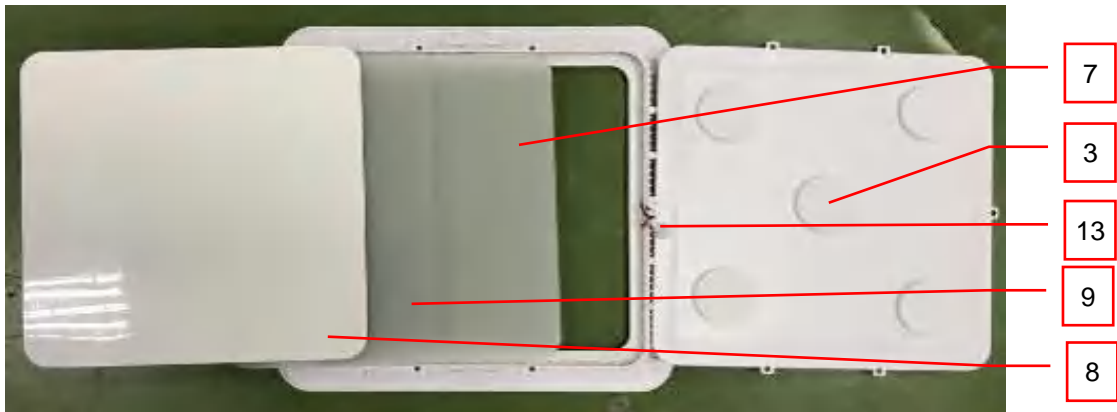


**3.0 Product Photographs**

**Photo 109** - Back view of JXL-CF08-T25W-UDD-xx

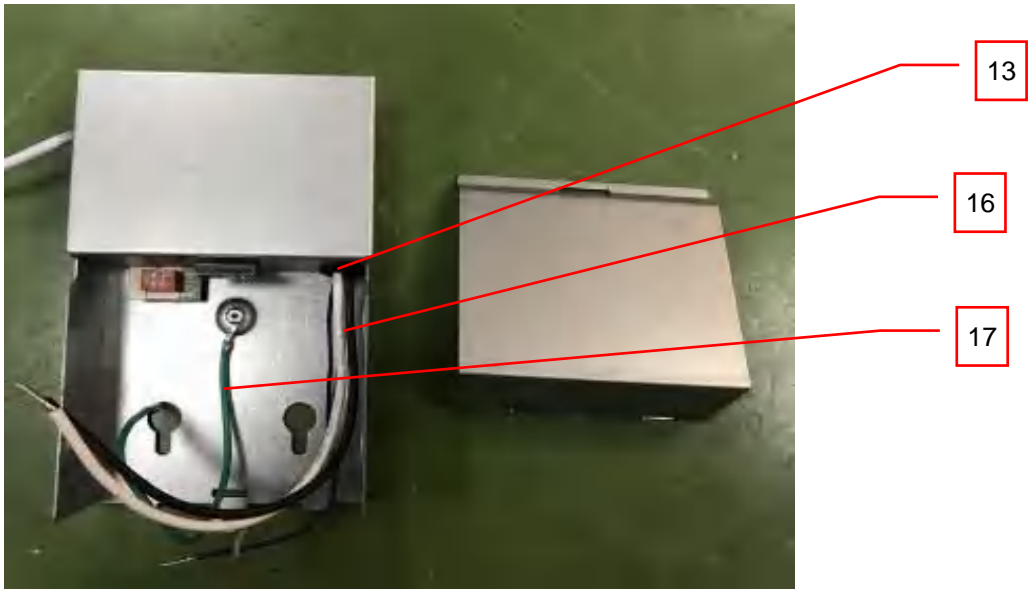


**Photo 110** - Internal view of JXL-CF08-T25W-UDD-xx

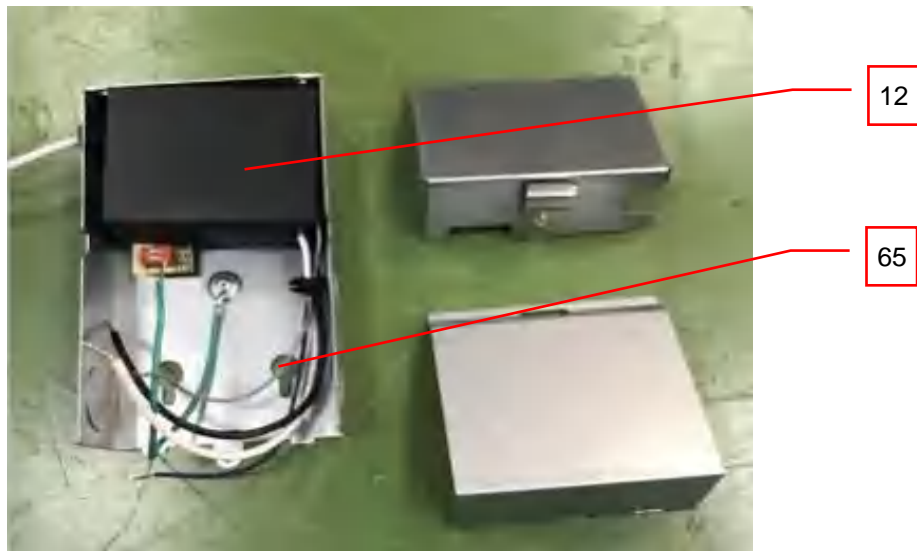


**3.0 Product Photographs**

**Photo 113** - Internal view of JXL-CA08-T25W-UDD-xx, it also represent model JXL-CF08-T25W-UDD-xx



**Photo 114** - Internal view of JXL-CA08-T25W-UDD-xx, it also represent model JXL-CF08-T25W-UDD-xx

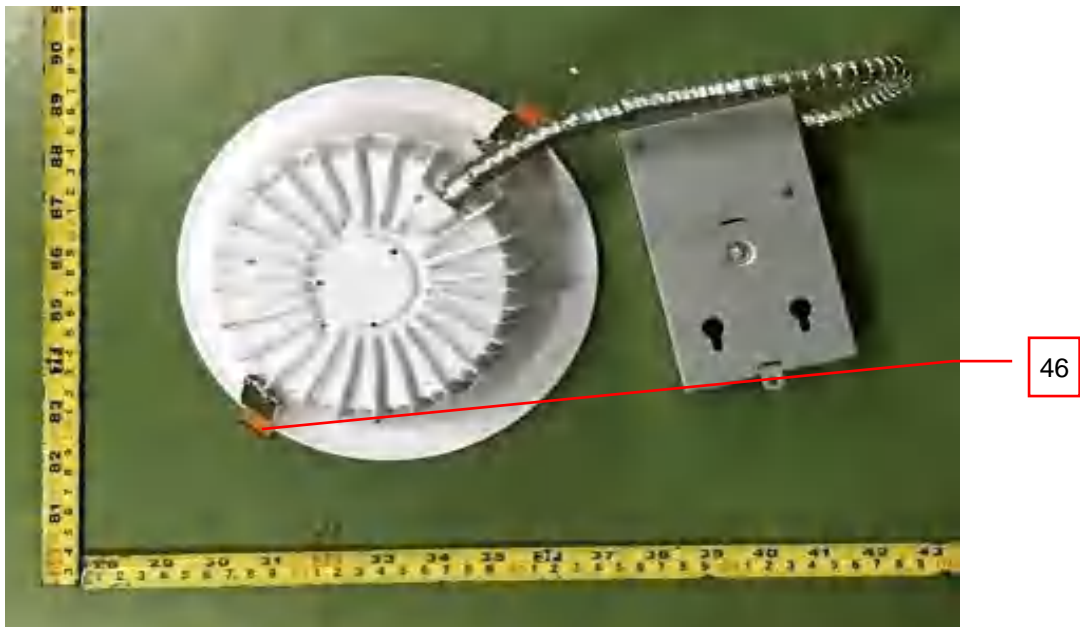


**3.0 Product Photographs**

**Photo 115** - External view of JXL-TE06-T25W-CCT-xx, it also represent model JXL-TE06-E25/18/15W-UDD-xx



**Photo 116** - Back view of JXL-TE06-T25W-CCT-xx, it also represent model JXL-TE06-E25/18/15W-UDD-xx



### 3.0 Product Photographs

**Photo 117** - External view of JXL-TE08-T25W-CCT-xx, it also represent model JXL-TE08-E25/18/15W-UDD-xx, JXL-TE08-E36W-UDD-xx

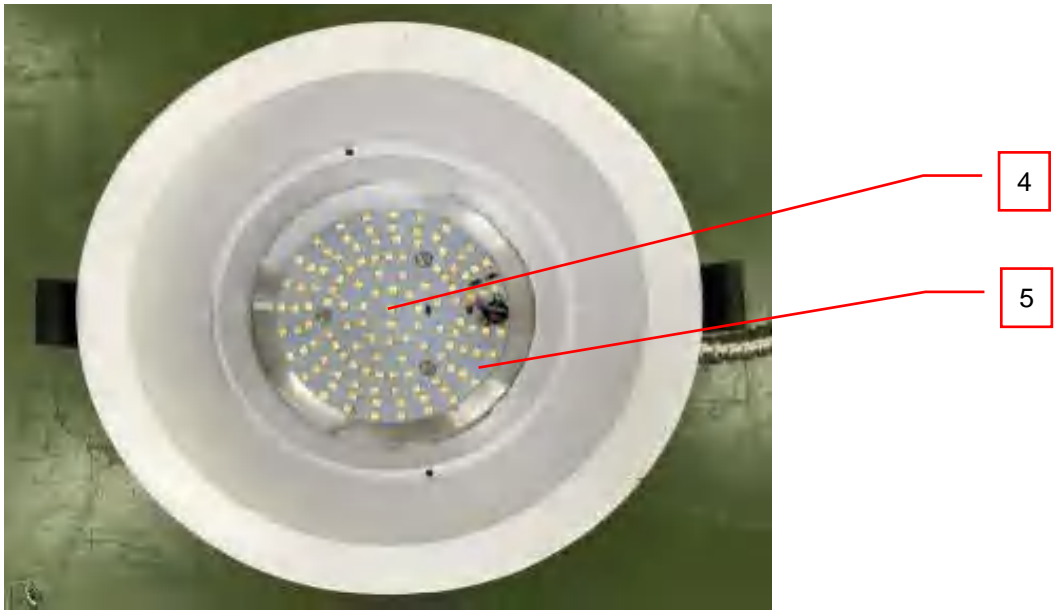


**Photo 118** - Back view of JXL-TE08-T25W-CCT-xx, it also represent model JXL-TE08-E25/18/15W-UDD-xx, JXL-TE08-E36W-UDD-xx

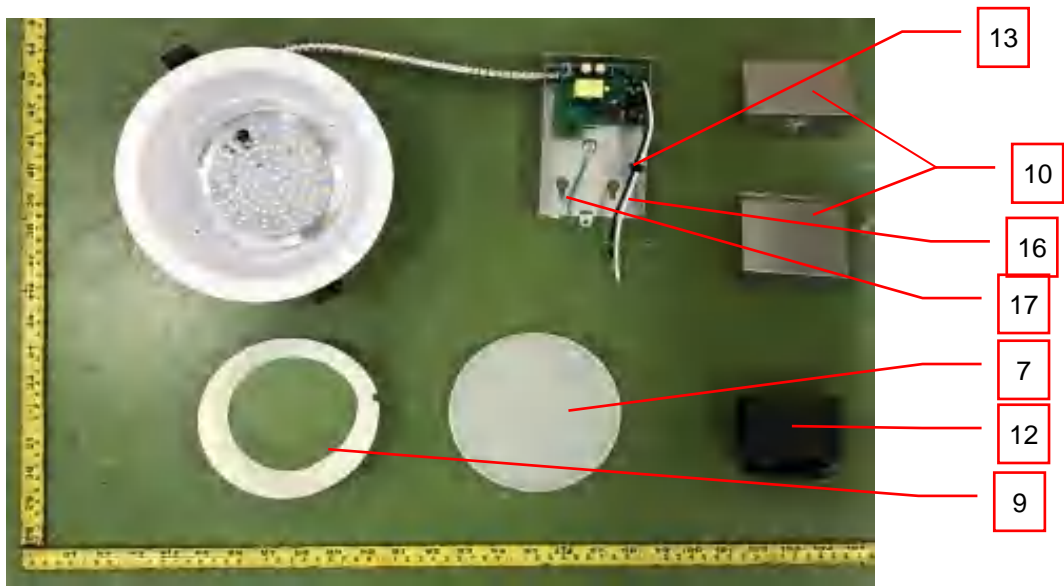


**3.0 Product Photographs**

**Photo 119** - Internal view of JXL-TE08-T25W-CCT-xx, it also represent model JXL-TE06-T25W-CCT-xx



**Photo 120** - Internal view of JXL-TE08-T25W-CCT-xx, it also represent model JXL-TE06-T25W-CCT-xx



**3.0 Product Photographs**

**Photo 121** - Internal view of JXL-TE08-E25/18/15W-UDD-xx, it also represent model JXL-TE06-E25/18/15W-UDD-xx

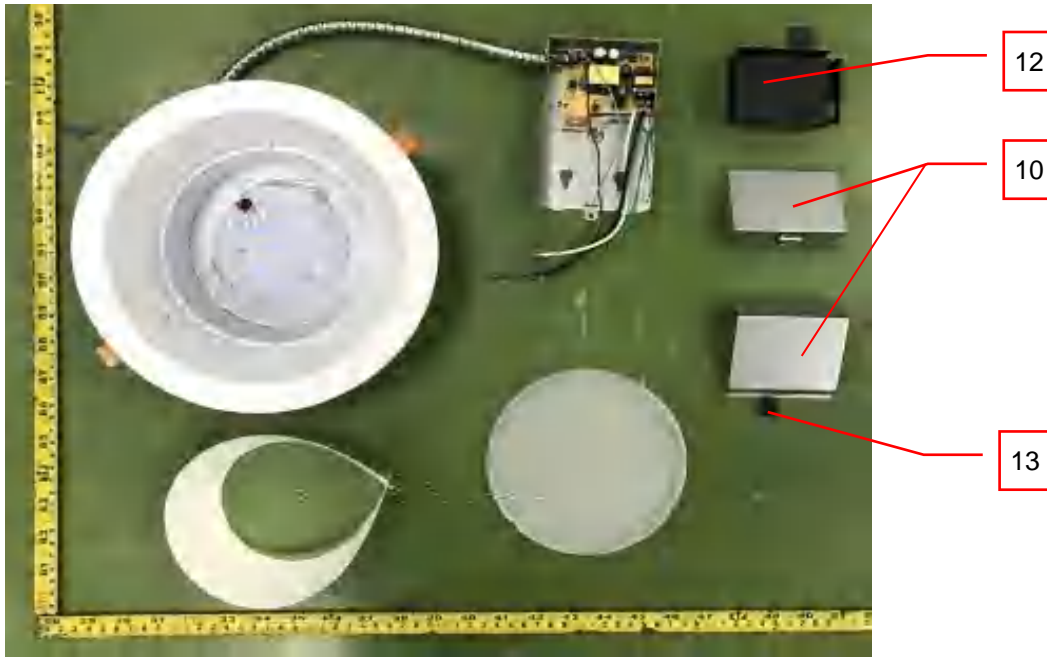


**Photo 121a** - Internal view of JXL-TE08-E36W-UDD-xx

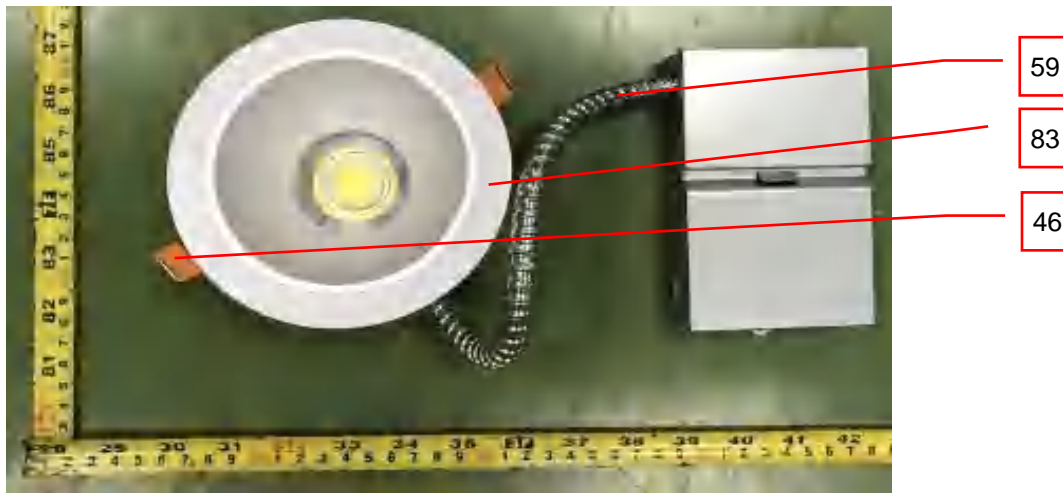


**3.0 Product Photographs**

**Photo 122** - Internal view of JXL-TE08-E25/18/15W-UDD-xx, it also represent model JXL-TE06-E25/18/15W-UDD-xx, JXL-TE08-E36W-UDD-xx



**Photo 123** - External view of JXL-COB04-E15W-UDD-xx

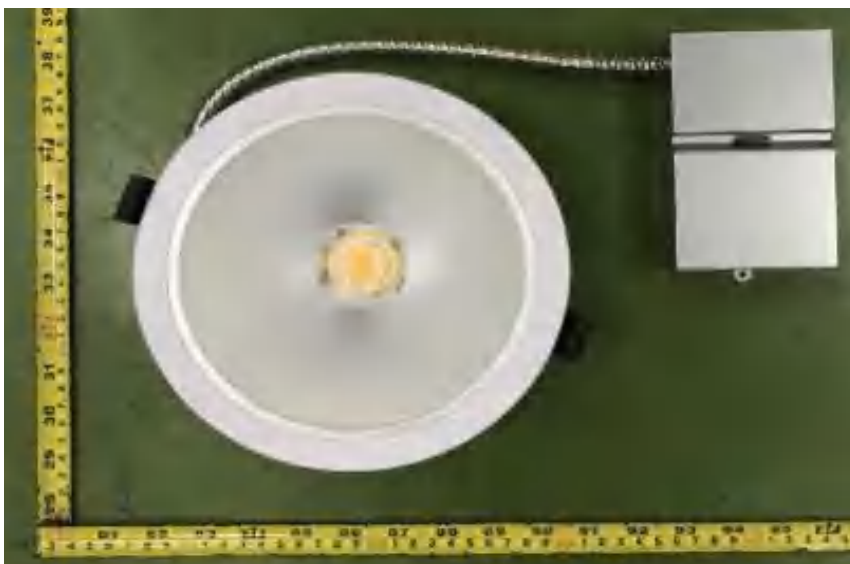


**3.0 Product Photographs**

**Photo 124** - Back view of JXL-COB04-E15W-UDD-xx



**Photo 125** - External view of JXL-COB06-F25/18/15W-UDD-xx

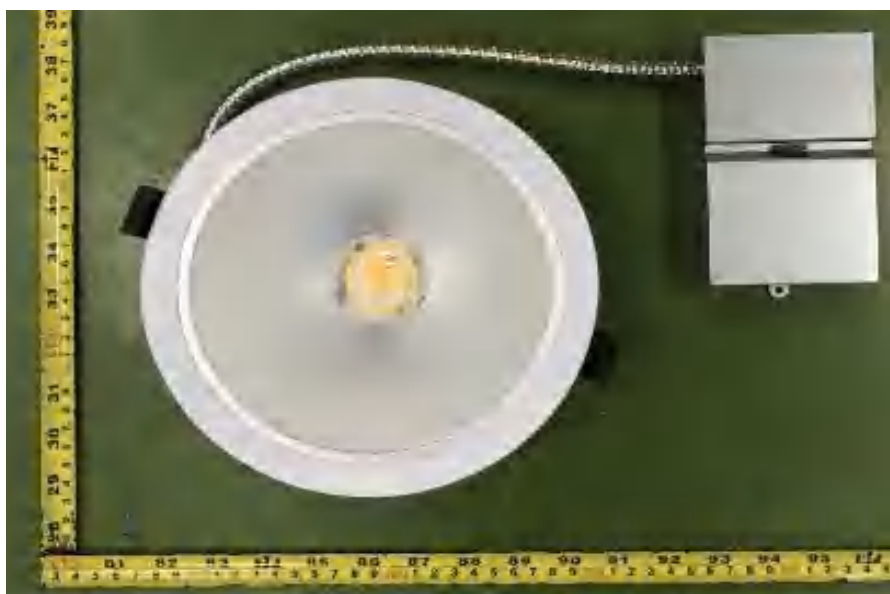


### 3.0 Product Photographs

**Photo 126** - Back view of JXL-COB06-F25/18/15W-UDD-xx



**Photo 127** - External view of JXL-COB08-F25/18/15W-UDD-xx



### 3.0 Product Photographs

**Photo 128** - External view of JXL-COB08-F36W-UDD-xx

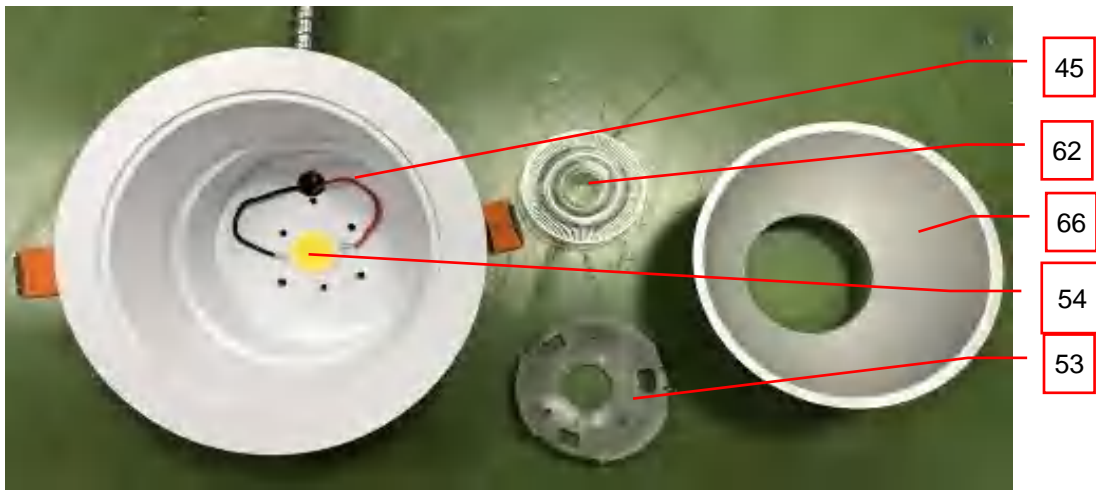


**Photo 129** - Back view of JXL-COB08-F25/18/15W-UDD-xx, it also represent model JXL-COB08-F36W-UDD-xx



**3.0 Product Photographs**

**Photo 130** - Internal view of JXL-COB04-E15W-UDD-xx, it also represent model JXL-COB06-F25/18/15W-UDD-xx, JXL-COB08-F25/18/15W-UDD-xx

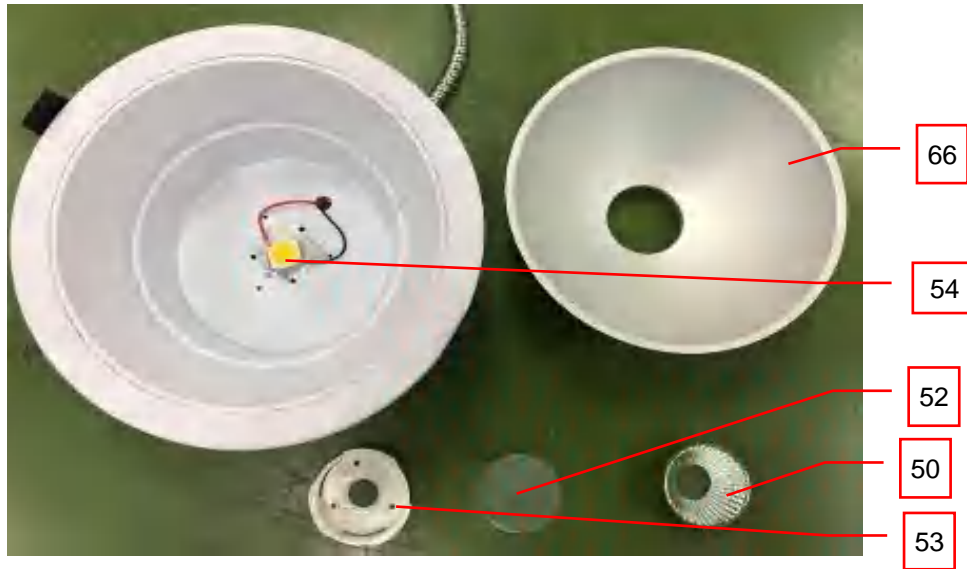


**Photo 131** - Internal view of JXL-COB04-E15W-UDD-xx, it also represent model JXL-COB06-F25/18/15W-UDD-xx, JXL-COB08-F25/18/15W-UDD-xx, JXL-COB08-F36W-UDD-xx



**3.0 Product Photographs**

**Photo 132** - Internal view of JXL-COB08-F36W-UDD-xx



**Photo 133** - Internal view of JXL-COB08-F36W-UDD-xx

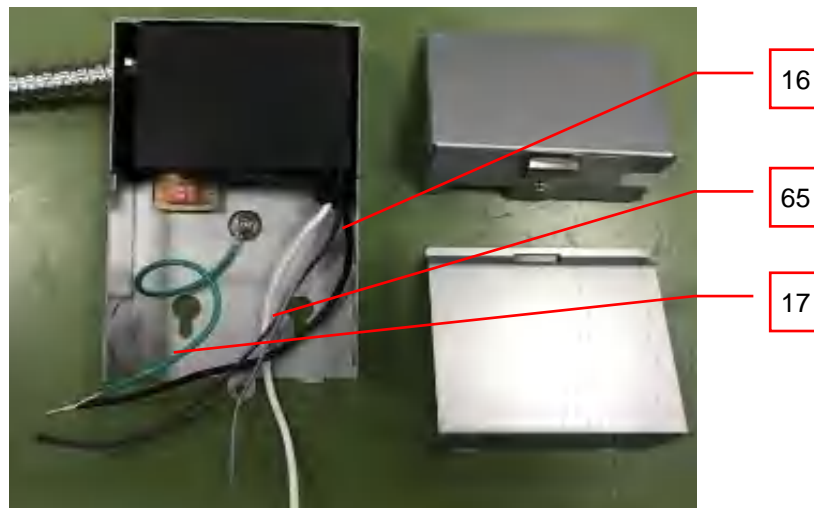


**3.0 Product Photographs**

**Photo 134** - Internal view of JXL-TE06-T25W-CCT-xx, it also represent model JXL-TE08-T25W-CCT-xx

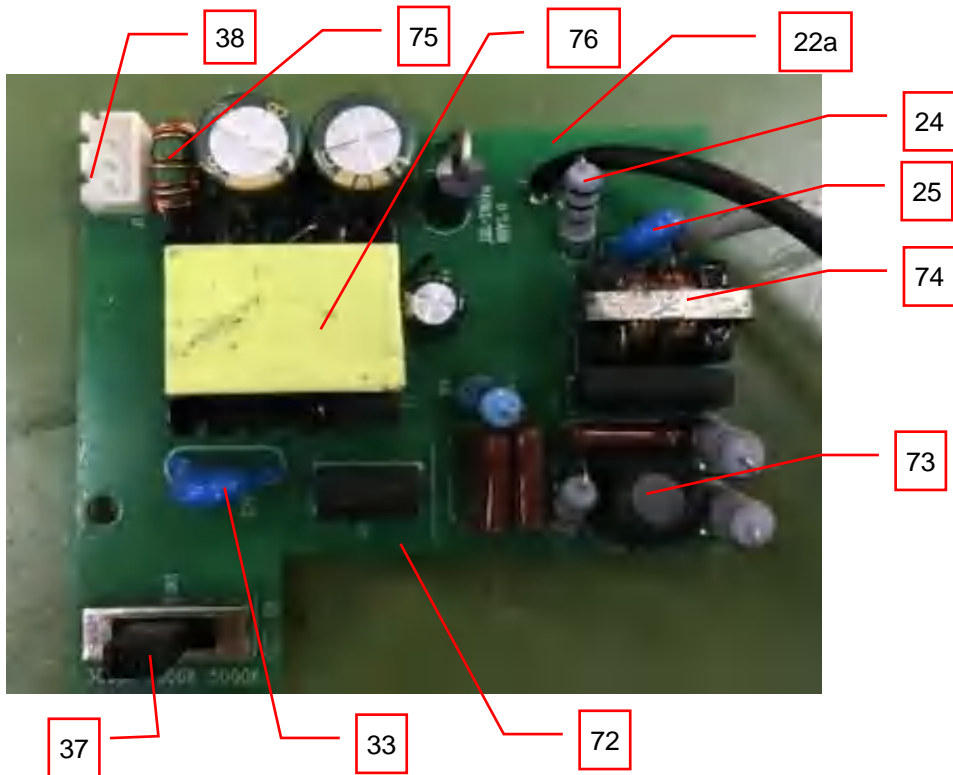


**Photo 135** - Internal view of JXL-TE06-E25/18/15W-UDD-xx, it also represent model JXL-TE08-E25/18/15W-UDD-xx, JXL-TE08-E36W-UDD-xx, JXL-CA08-T25W-UDD-xx, JXL-CF08-T25W-UDD-xx, JXL-COB04-E15W-UDD-xx, JXL-COB06-F25/18/15W-UDD-xx, JXL-COB08-F25/18/15W-UDD-xx, JXL-COB08-F36W-UDD-xx



**3.0 Product Photographs**

**Photo 138** - Front view of driver PCB of models JXL-TE06-T25W-CCT-xx, it also represent model JXL-TE08-T25W-CCT-xx

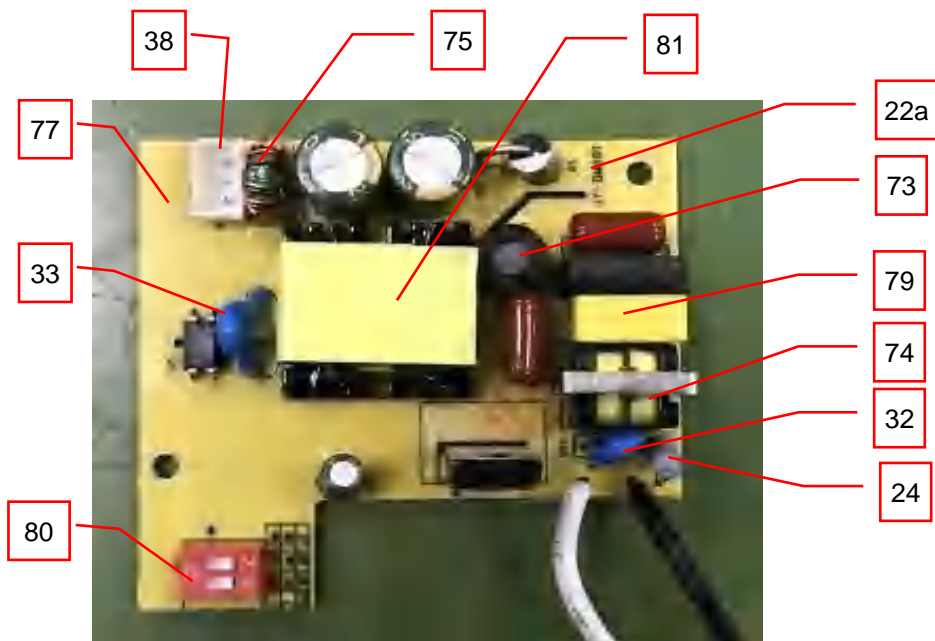


**Photo 139** - Rear view of driver PCB of models JXL-TE06-T25W-CCT-xx, it also represent model JXL-TE08-T25W-CCT-xx

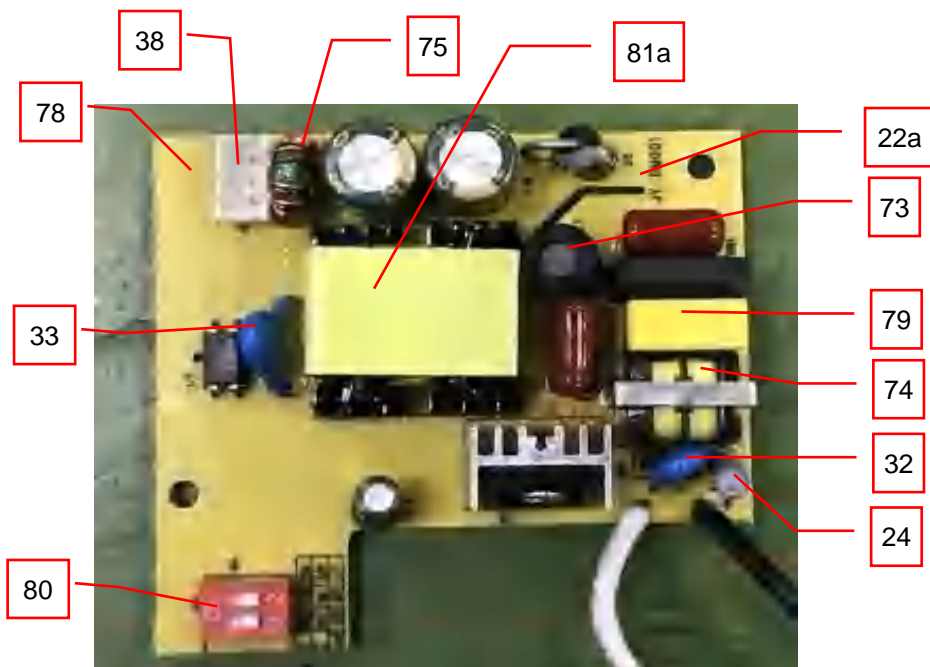


### 3.0 Product Photographs

**Photo 140** - Front view of driver PCB of models JXL-TE06-E25/18/15W-UDD-xx, it also represent model JXL-TE08-E25/18/15W-UDD-xx, JXL-CA08-T25W-UDD-xx, JXL-CF08-T25W-UDD-xx, JXL-COB04-E15W-UDD-xx, JXL-COB06-F25/18/15W-UDD-xx, JXL-COB08-F25/18/15W-UDD-xx



**Photo 141** - Front view of driver PCB of models JXL-TE08-E36W-UDD-xx, it also represent model JXL-COB08-F36W-UDD-xx



### 3.0 Product Photographs

**Photo 142** - Rear view of driver PCB of models JXL-TE06-E25/18/15W-UDD-xx, it also represent model JXL-TE08-E25/18/15W-UDD-xx, JXL-TE08-E36W-UDD-xx, JXL-CA08-T25W-UDD-xx, JXL-CF08-T25W-UDD-xx, JXL-COB04-E15W-UDD-xx, JXL-COB06-F25/18/15W-UDD-xx, JXL-COB08-F25/18/15W-UDD-xx, JXL-COB08-F36W-UDD-xx



**Photo 143** - External view of JXL-COB02-R08W-UDN-XX, JXL-COB04-R12W-UDN-XX, JXL-COB04-R15W-UDN-XX, JXL-COB04-R12W-CCT, JXL-COB04-R15W-CCT, JXL-COB02-R08W-CCT (Group 1)

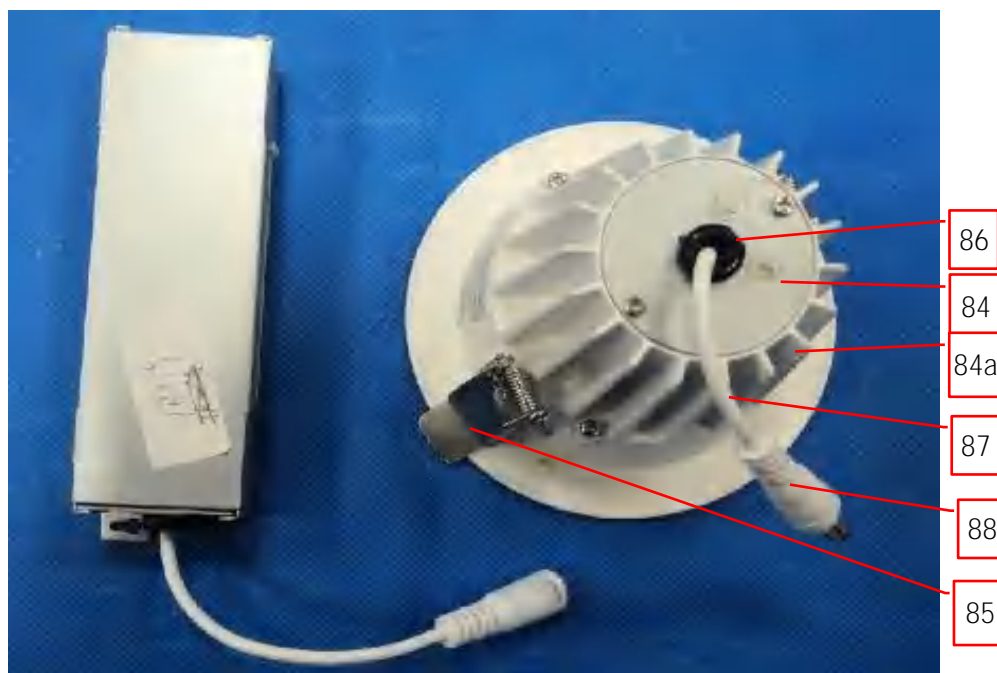


**3.0 Product Photographs**

**Photo 144** - External view of JXL-COB02-R08W-UDN-XX, JXL-COB04-R12W-UDN-XX, JXL-COB04-R15W-UDN-XX, JXL-COB04-R12W-CCT, JXL-COB04-R15W-CCT, JXL-COB02-R08W-CCT (Group 1)

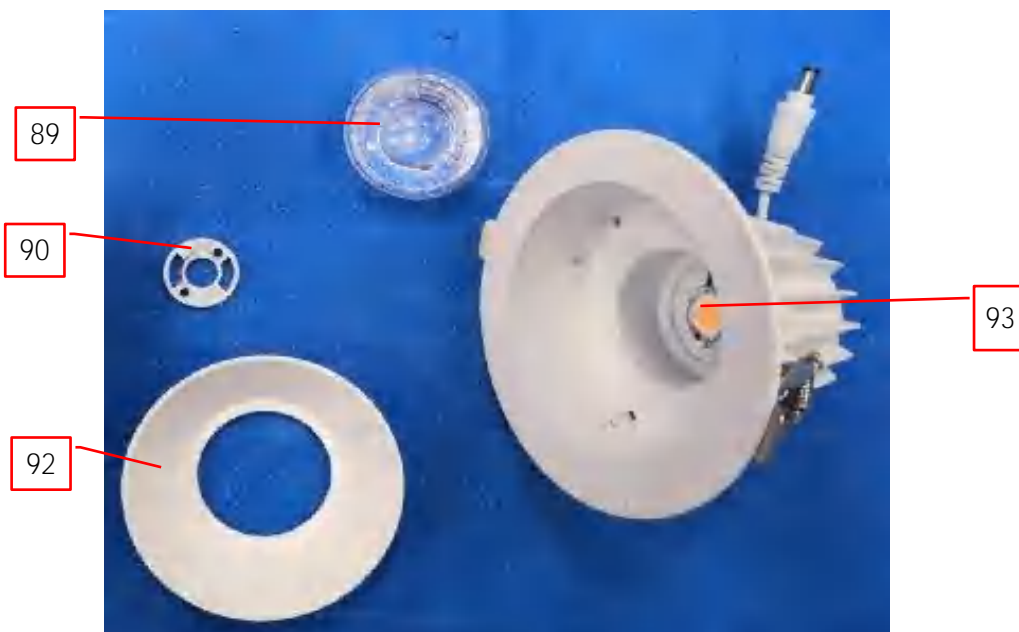


**Photo 145** - External view of JXL-COB02-R08W-UDN-XX, also represent JXL-COB04-R12W-UDN-XX, JXL-COB04-R15W-UDN-XX, JXL-COB04-R12W-CCT, JXL-COB04-R15W-CCT, JXL-COB02-R08W-CCT(Group 1)

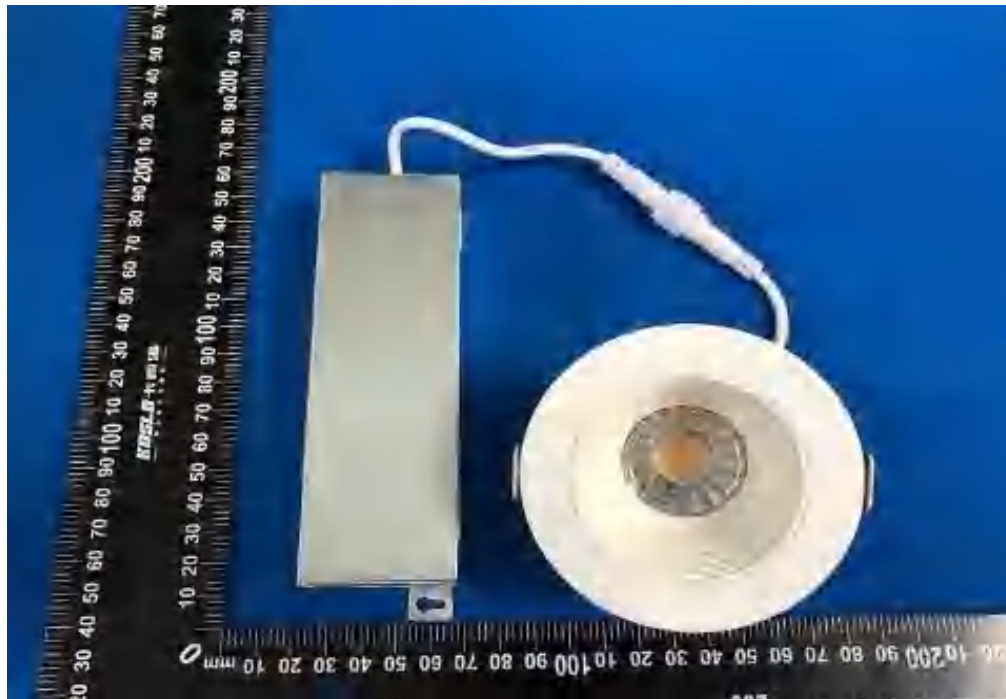


### 3.0 Product Photographs

**Photo 146** - Internal view of LED Panel for model JXL-COB02-R08W-UDN-XX, also represent JXL-COB04-R12W-UDN-XX, JXL-COB04-R15W-UDN-XX, JXL-COB04-R12W-CCT, JXL-COB04-R15W-CCT, JXL-COB02-R08W-CCT(Group 1)

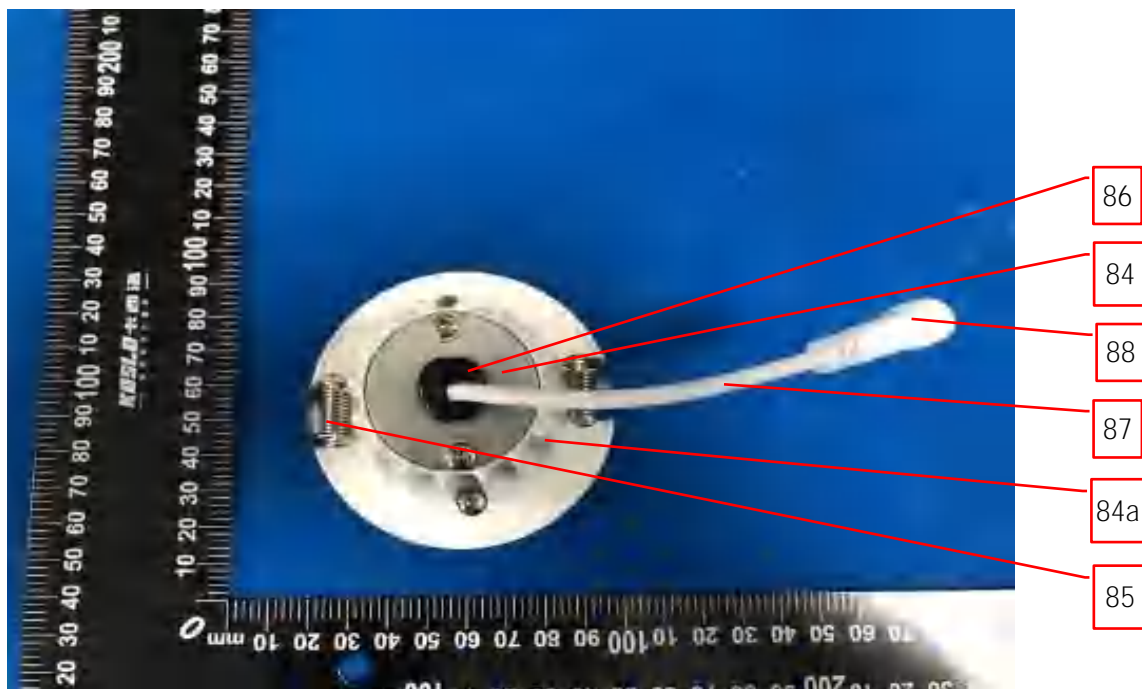


**Photo 146a** - Alternative external view of JXL-COB02-R08W-CCT

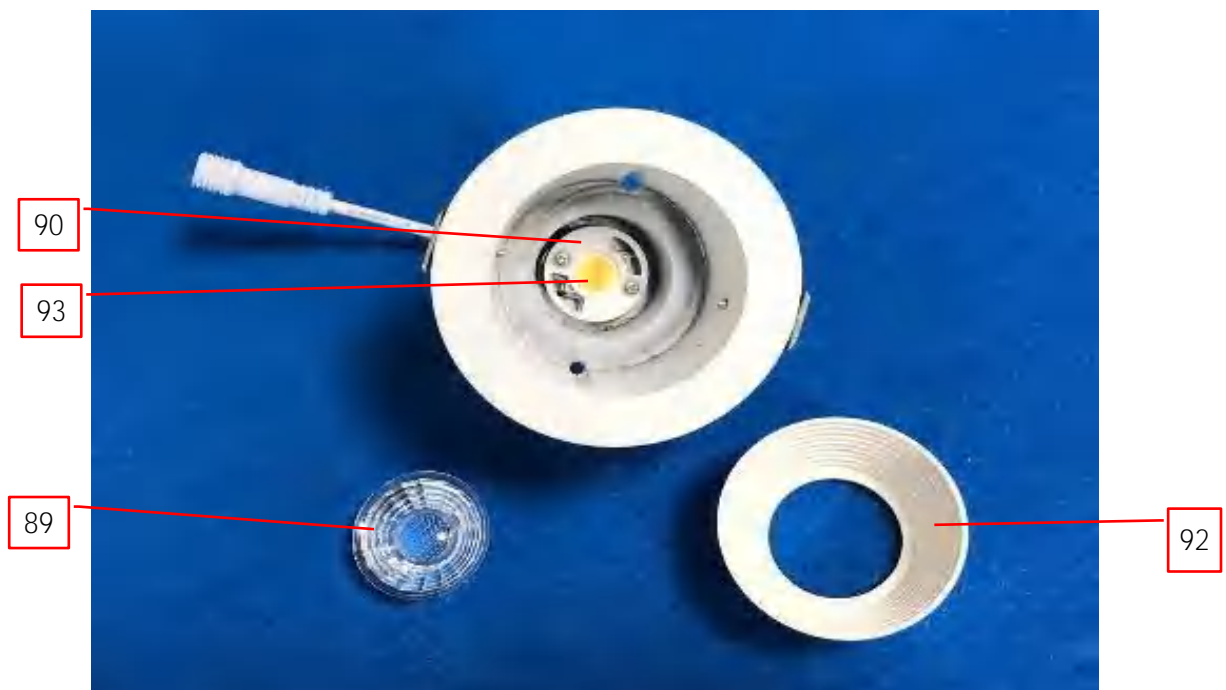


**3.0 Product Photographs**

**Photo 146b** - Alternative external view of JXL-COB02-R08W-CCT

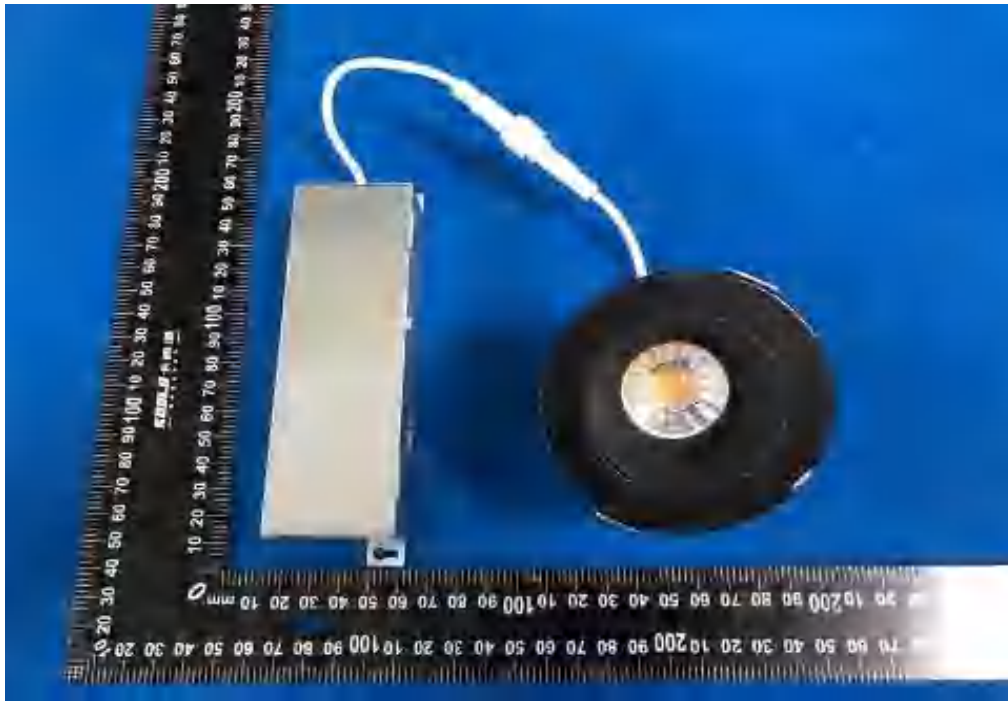


**Photo 146c** - Alternative internal view of JXL-COB02-R08W-CCT

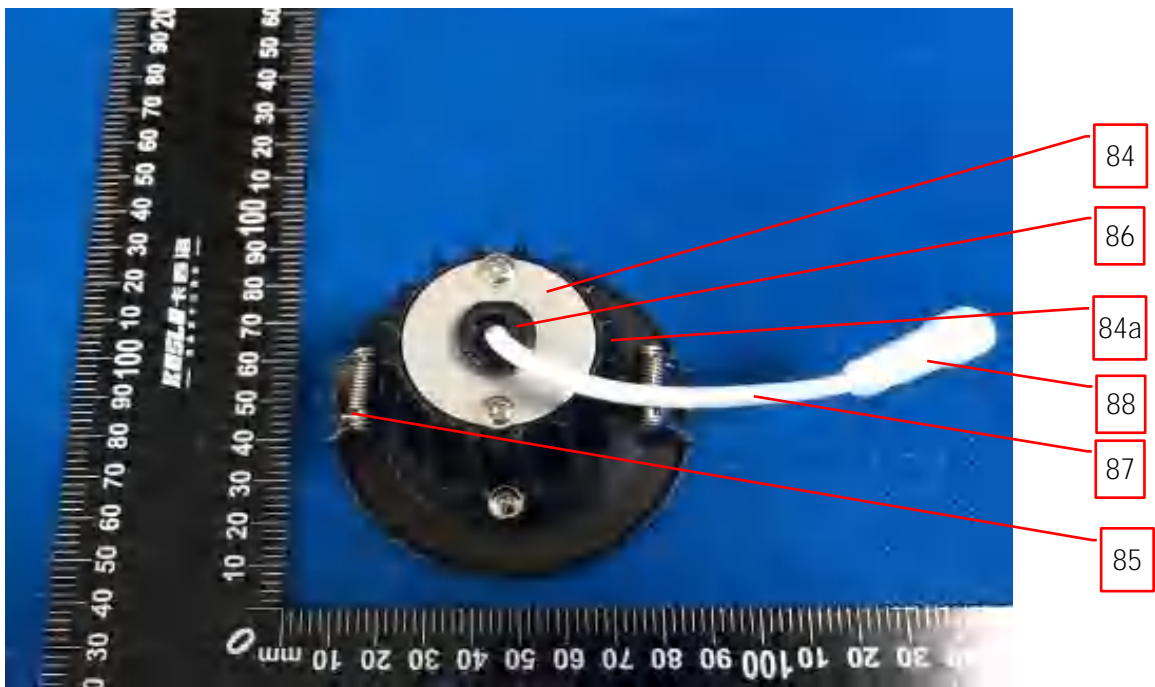


**3.0 Product Photographs**

**Photo 146d** - Alternative external view of JXL-COB02-R08W-CCT

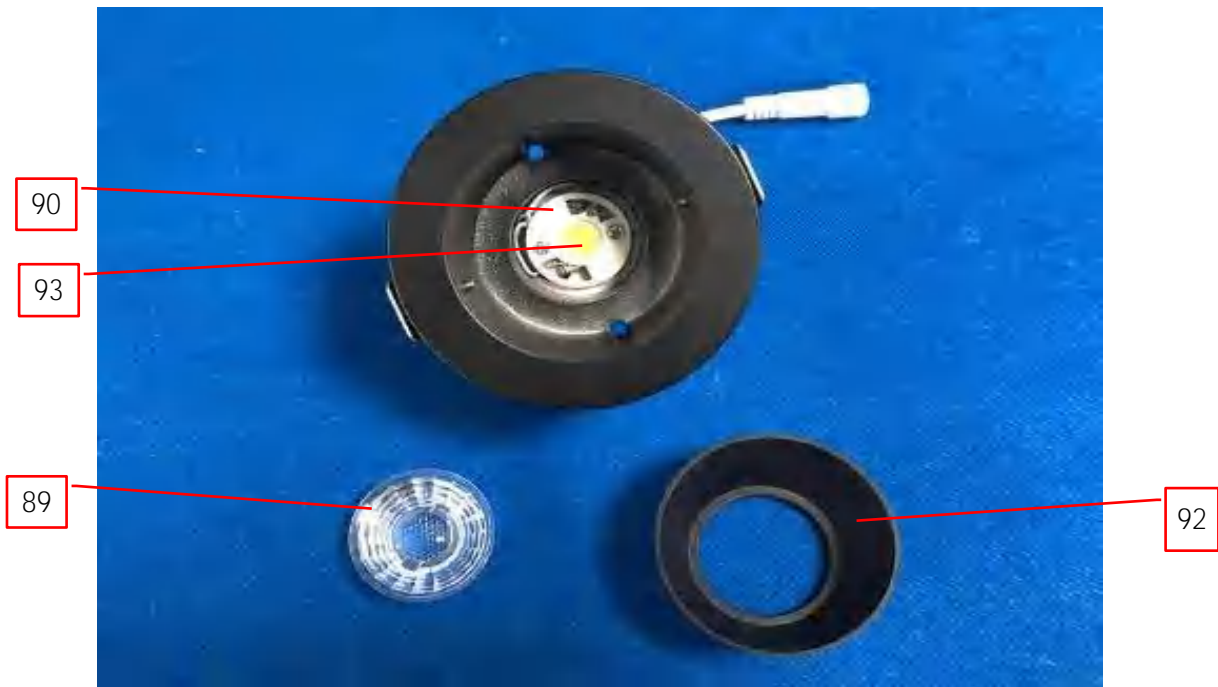


**Photo 146e** - Alternative external view of JXL-COB02-R08W-CCT

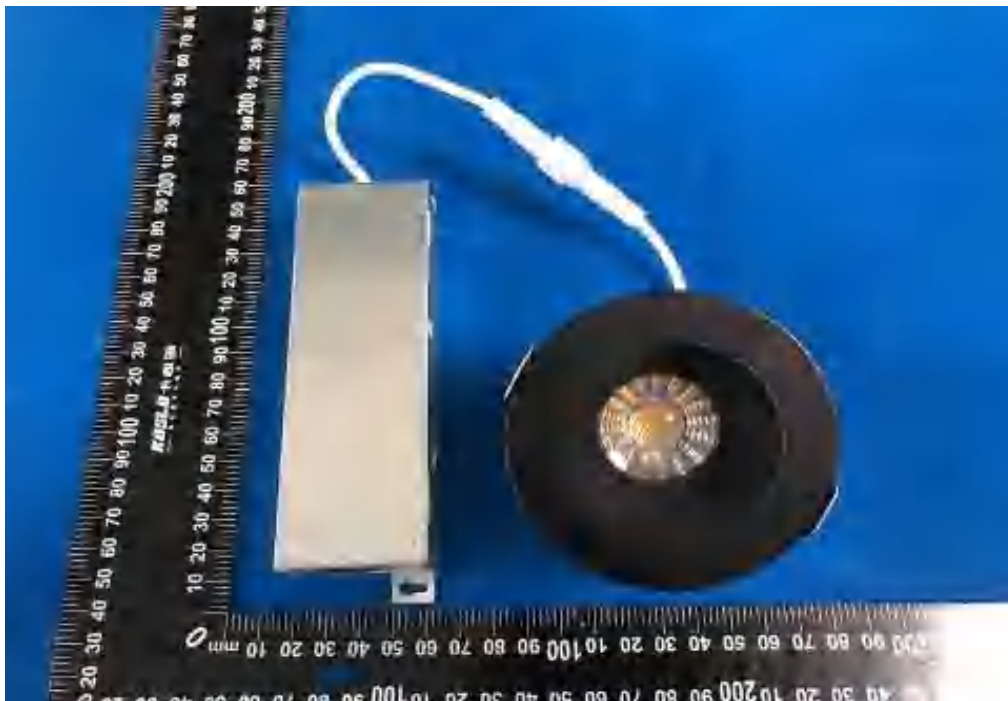


**3.0 Product Photographs**

**Photo 146f** - Alternative internal view of JXL-COB02-R08W-CCT

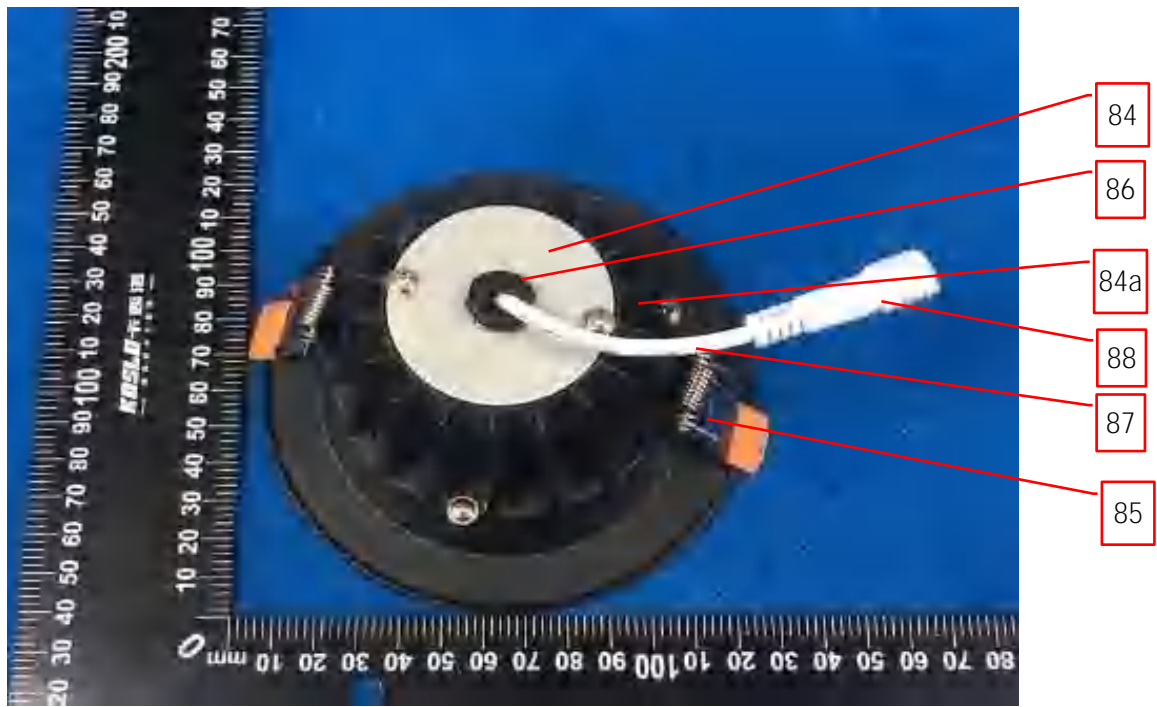


**Photo 146g** - Alternative external view of JXL-COB02-R08W-CCT



**3.0 Product Photographs**

**Photo 146h** - Alternative external view of JXL-COB02-R08W-CCT



**Photo 146i** - Alternative internal view of JXL-COB02-R08W-CCT

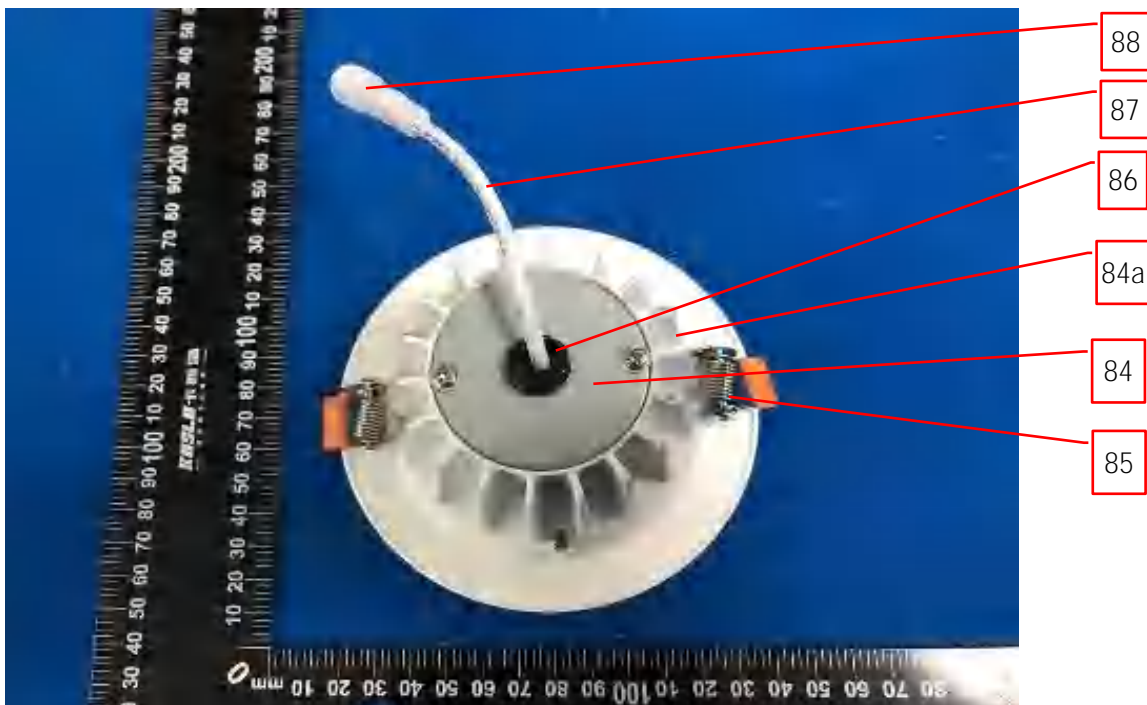


**3.0 Product Photographs**

**Photo 146j** - Alternative external view of JXL-COB04-R15W-CCT

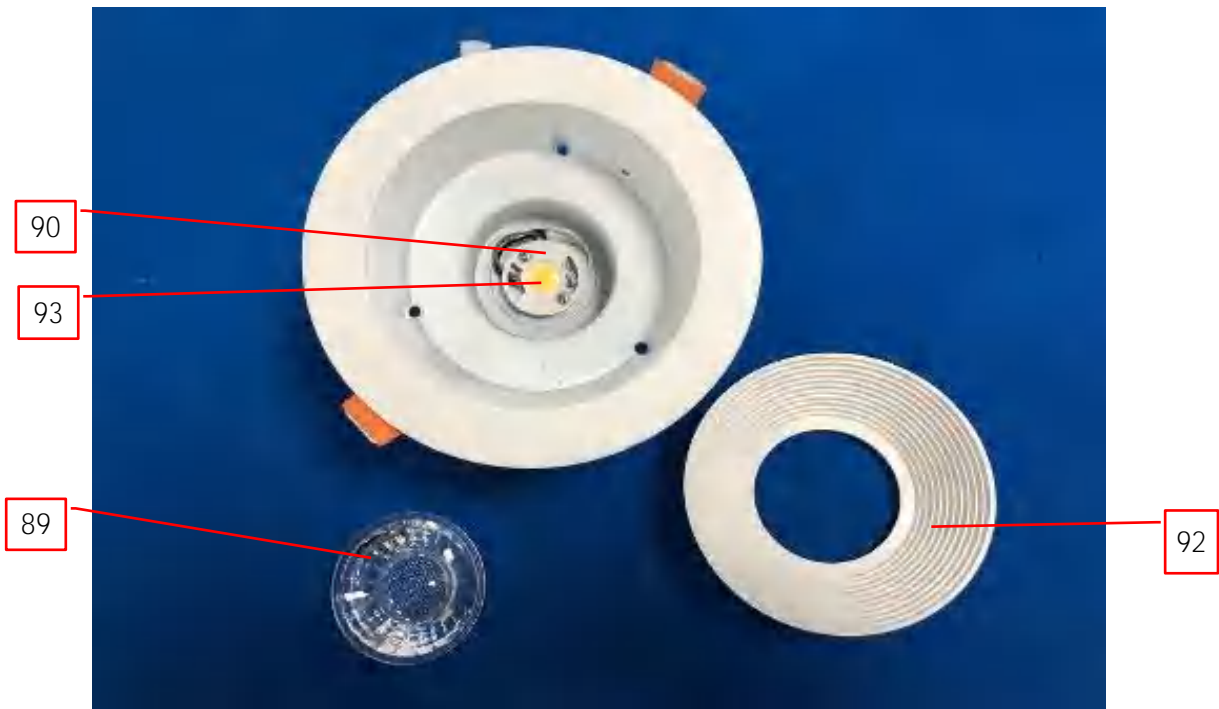


**Photo 146k** - Alternative external view of JXL-COB04-R15W-CCT

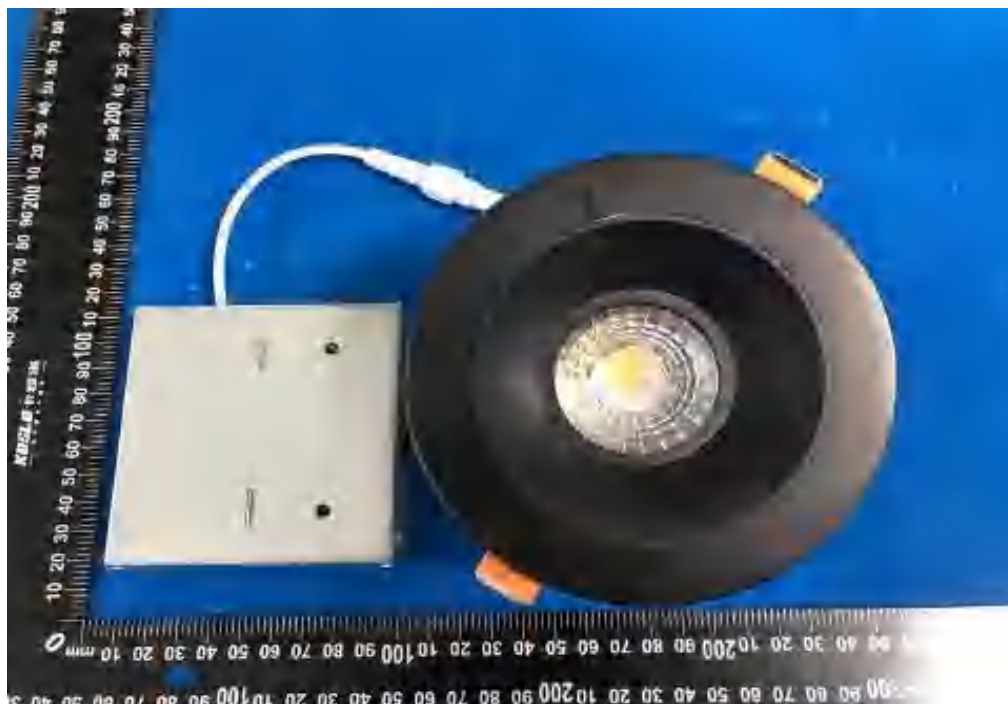


**3.0 Product Photographs**

**Photo 146l** - Alternative internal view of JXL-COB04-R15W-CCT

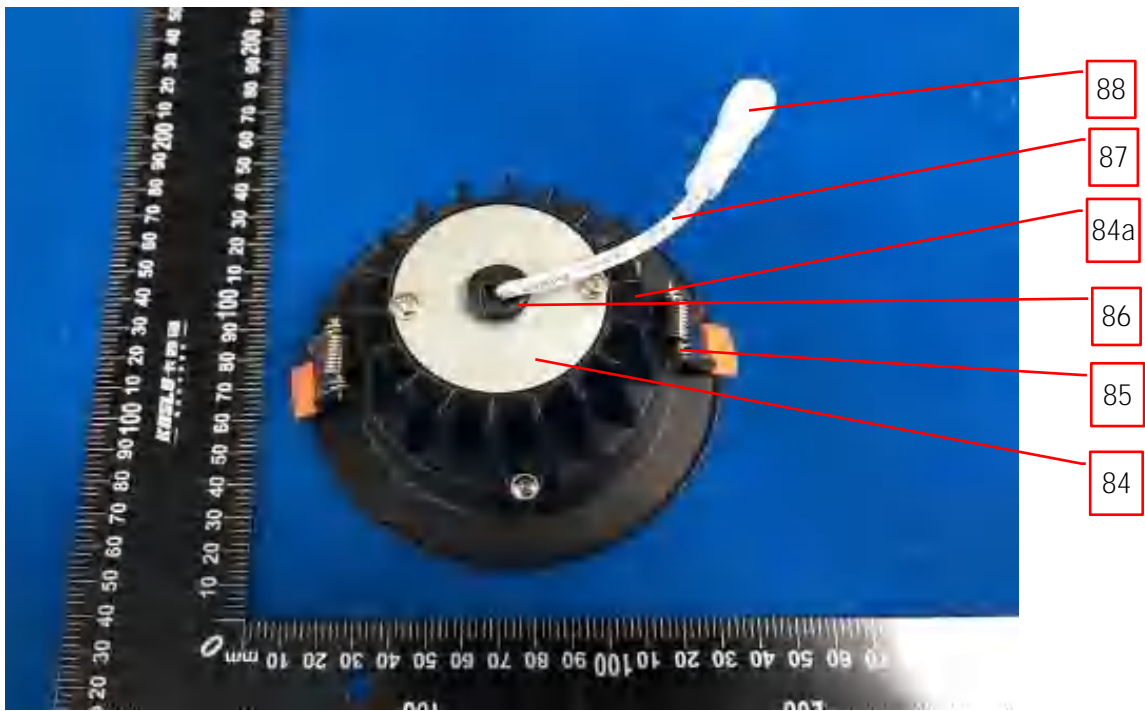


**Photo 146m** - Alternative external view of JXL-COB04-R15W-CCT

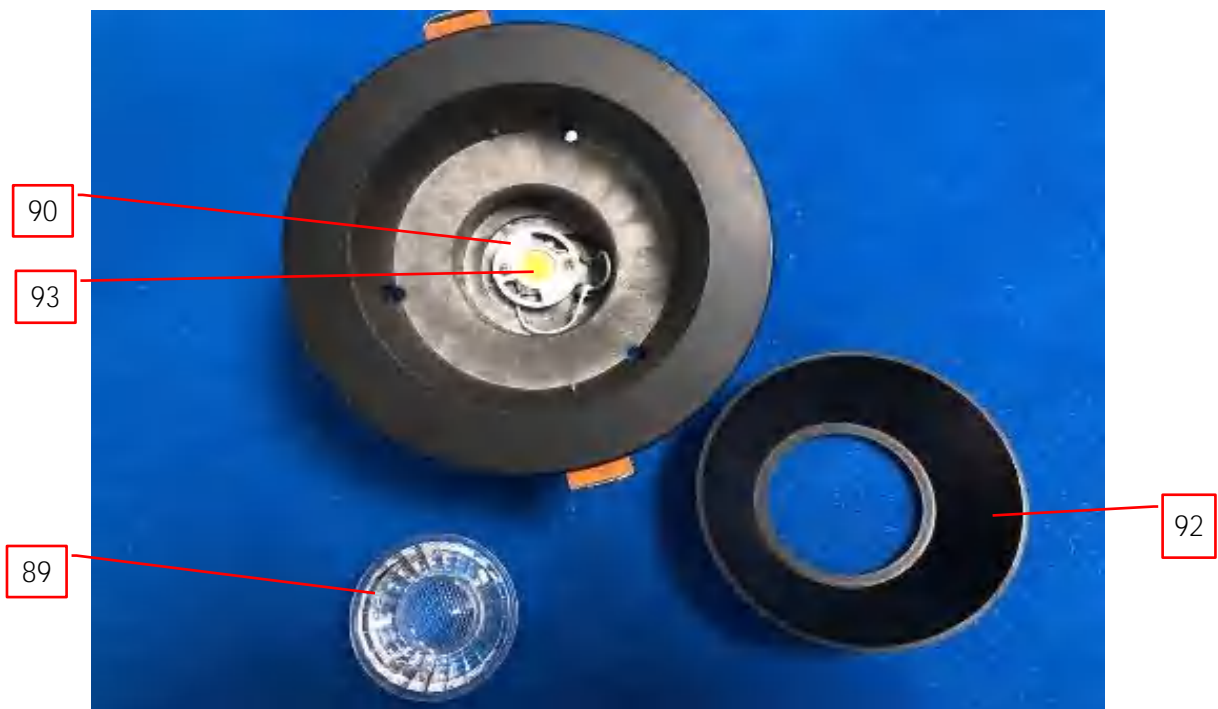


**3.0 Product Photographs**

**Photo 146n** - Alternative external view of JXL-COB04-R15W-CCT

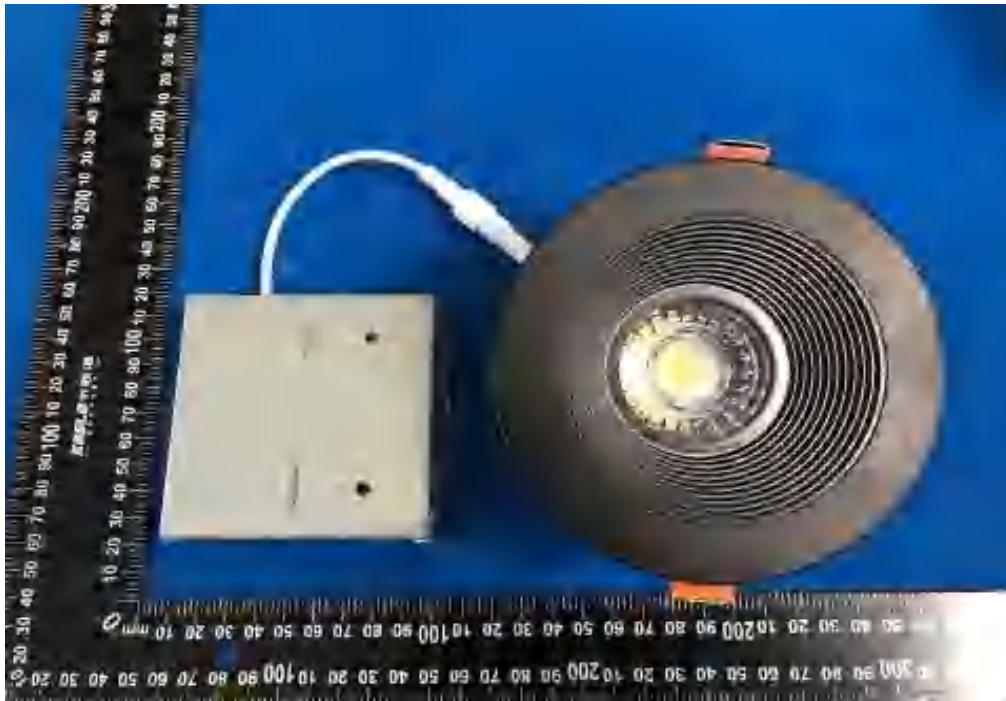


**Photo 146o** - Alternative internal view of JXL-COB04-R15W-CCT

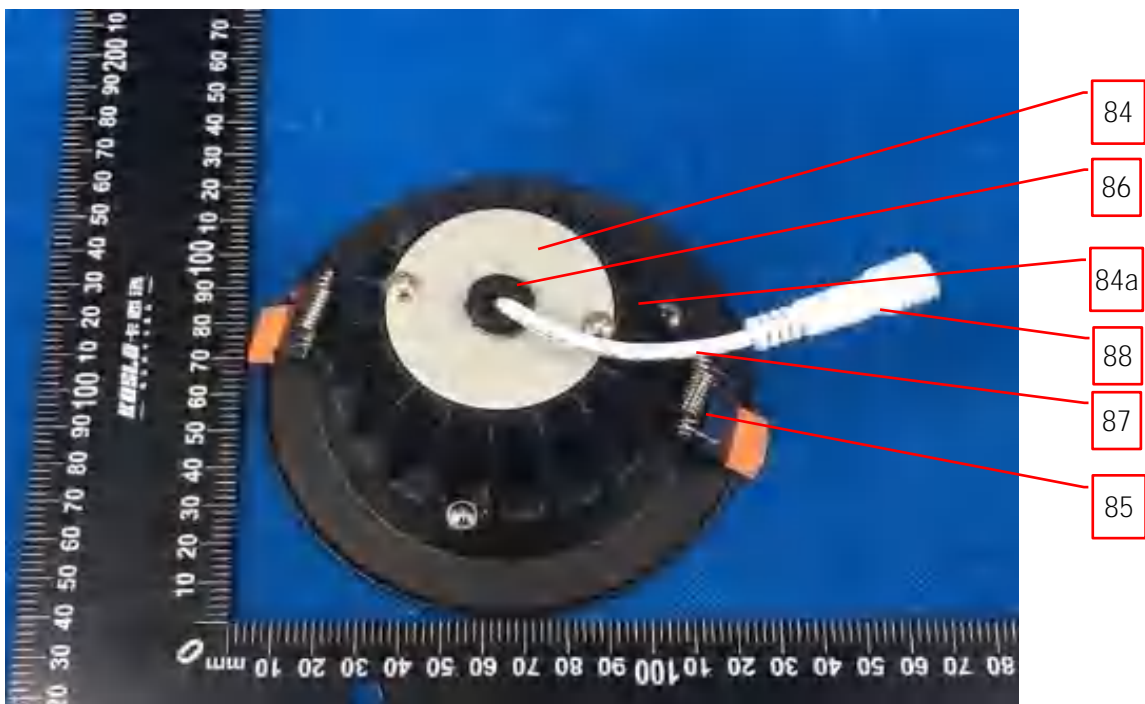


**3.0 Product Photographs**

**Photo 146p** - Alternative external view of JXL-COB04-R15W-CCT

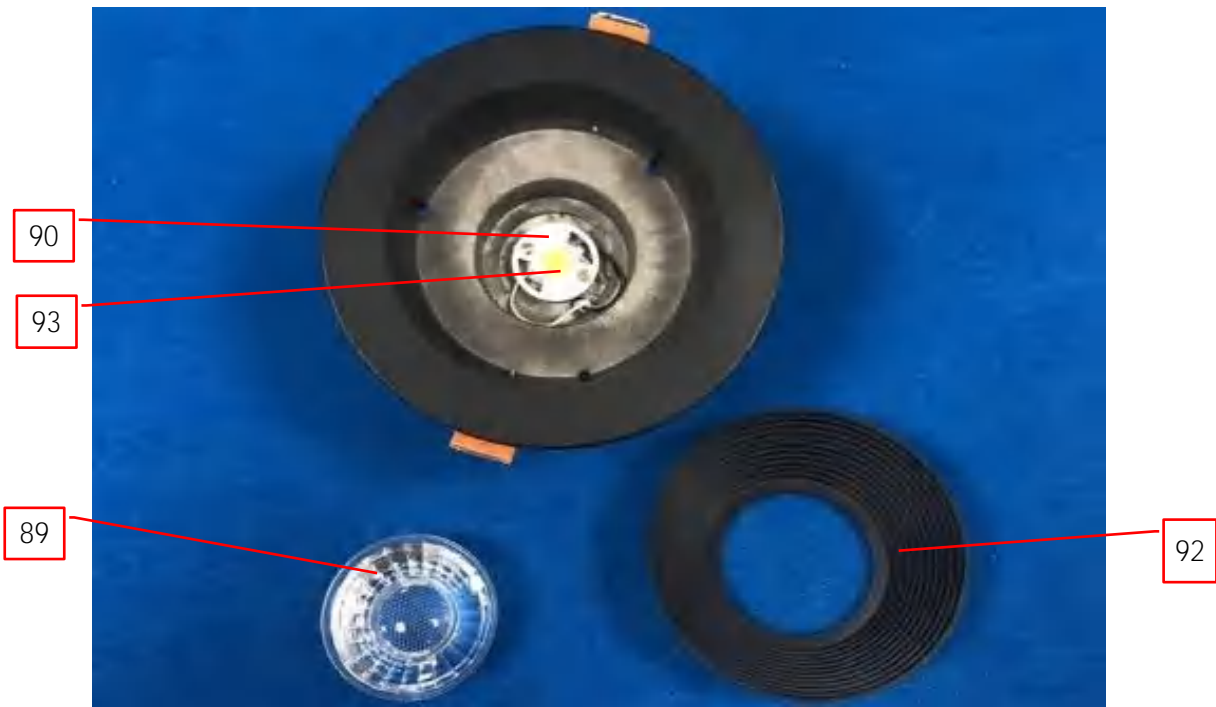


**Photo 146q** - Alternative external view of JXL-COB04-R15W-CCT



**3.0 Product Photographs**

**Photo 146r** - Alternative internal view of JXL-COB04-R15W-CCT



**Photo 147** - External view of JXL-COB02-S08W-UDN-XX, JXL-COB04-S12W-UDN-XX, JXL-COB04-S15W-UDN-XX, JXL-COB04-S12W-CCT, JXL-COB04-S15W-CCT, JXL-COB02-S08W-CCT (Group 2)

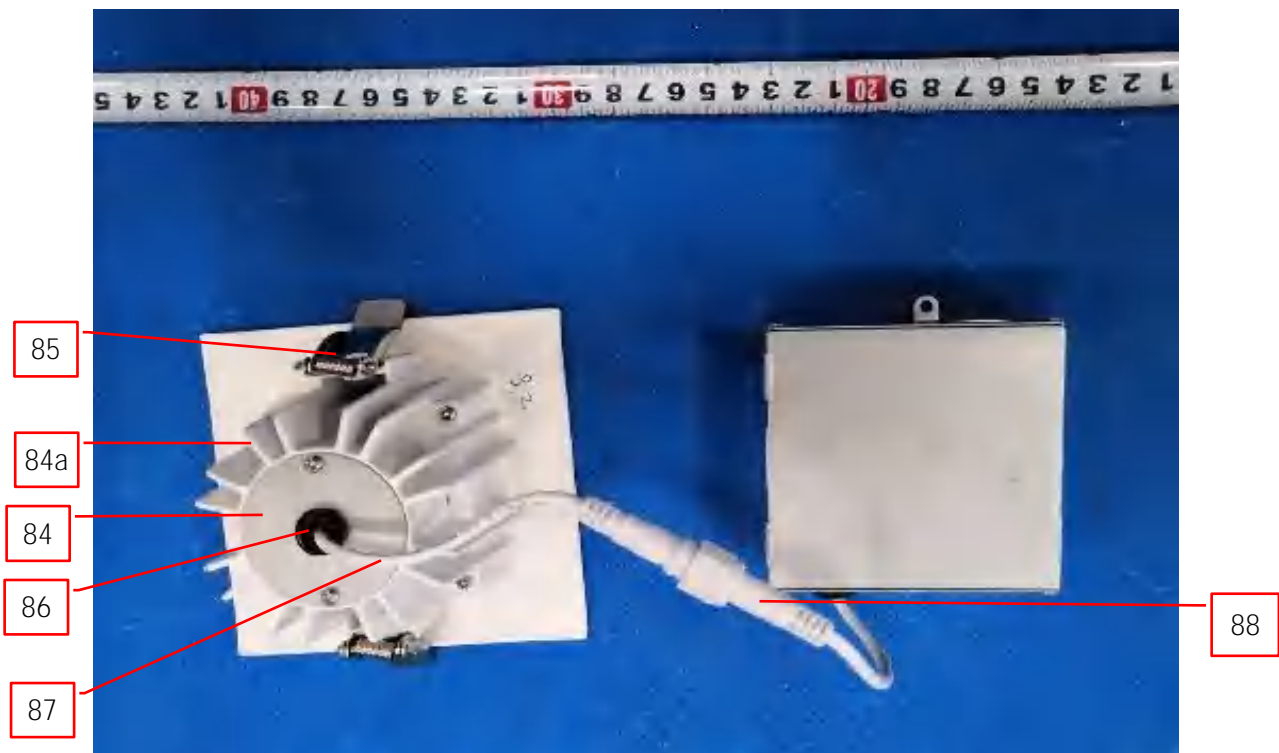


**3.0 Product Photographs**

**Photo 148** - External view of JXL-COB02-S08W-UDN-XX, JXL-COB04-S12W-UDN-XX, JXL-COB04-S15W-UDN-XX, JXL-COB04-S12W-CCT, JXL-COB04-S15W-CCT, JXL-COB02-S08W-CCT (Group 2)

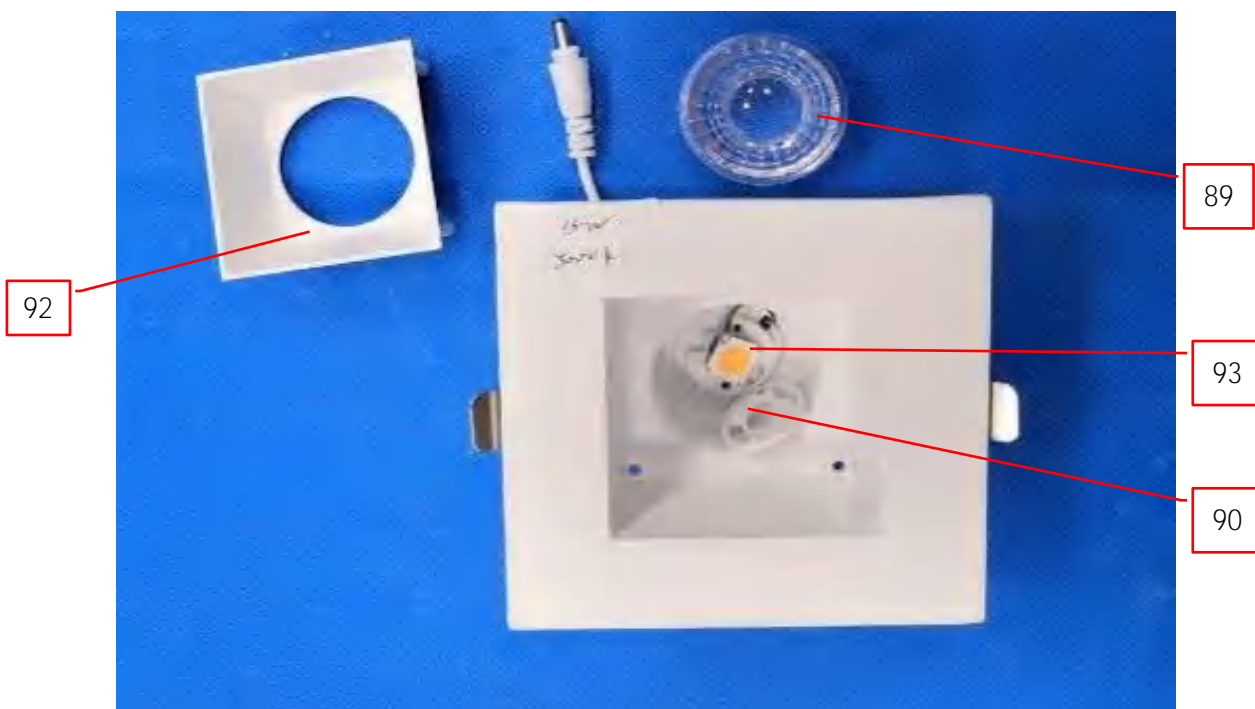


**Photo 149** - External view of JXL-COB04-S15W-UDN-XX, also represent JXL-COB02-S08W-UDN-XX, JXL-COB04-S12W-UDN-XX, JXL-COB04-S12W-CCT, JXL-COB04-S15W-CCT, JXL-COB02-S08W-CCT (Group 2)



### 3.0 Product Photographs

**Photo 150** - Internal view of LED Panel for model JXL-COB04-S15W-UDN-XX, also represent JXL-COB02-S08W-UDN-XX, JXL-COB04-S12W-UDN-XX, JXL-COB04-S12W-CCT, JXL-COB04-S15W-CCT, JXL-COB02-S08W-CCT (Group 2)

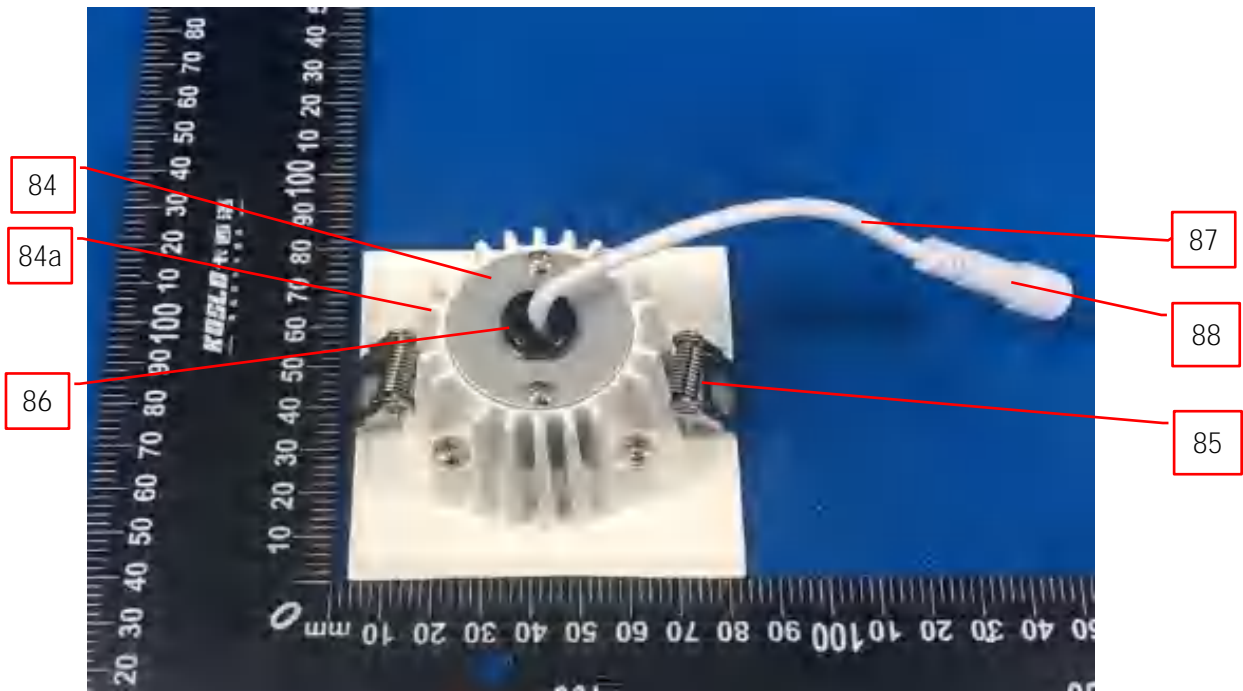


**Photo 150a** - Alternative external view of JXL-COB02-S08W-CCT

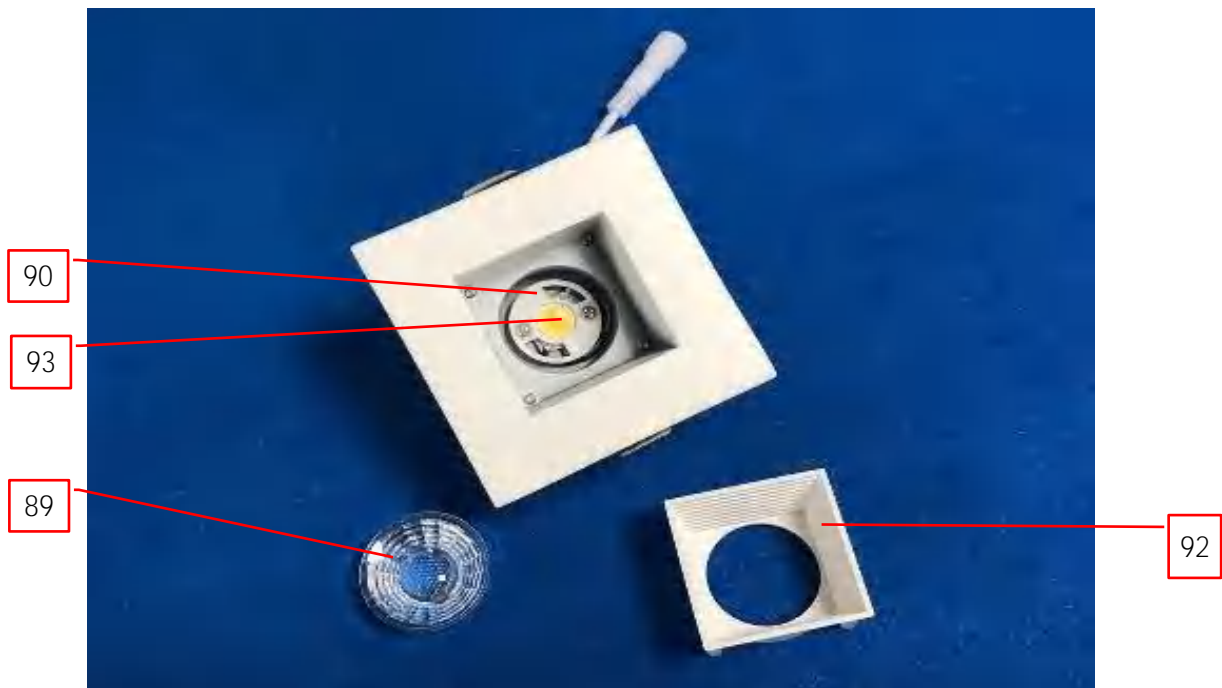


**3.0 Product Photographs**

**Photo 150b** - Alternative external view of JXL-COB02-S08W-CCT

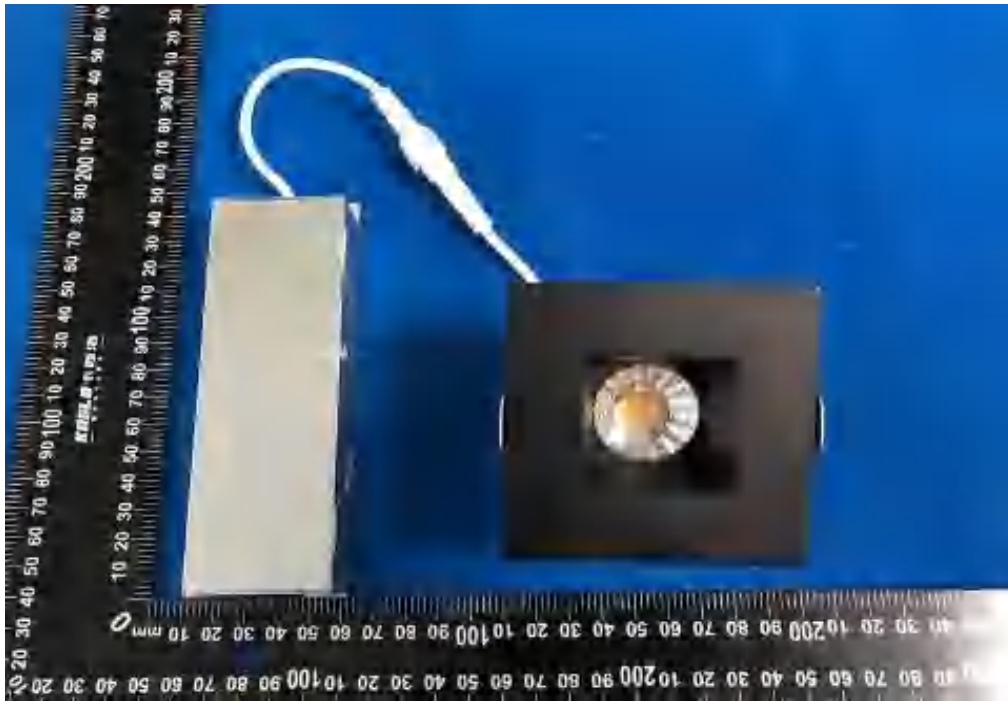


**Photo 150c** - Alternative internal view of JXL-COB02-S08W-CCT

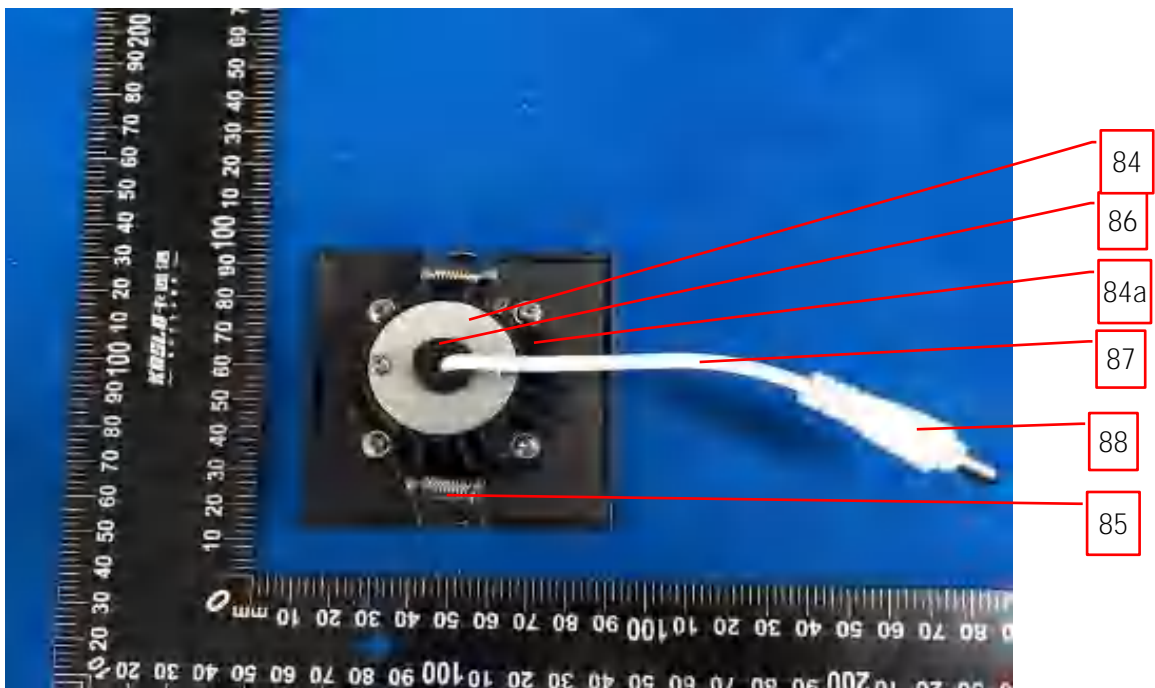


**3.0 Product Photographs**

**Photo 150d** - Alternative external view of JXL-COB02-S08W-CCT

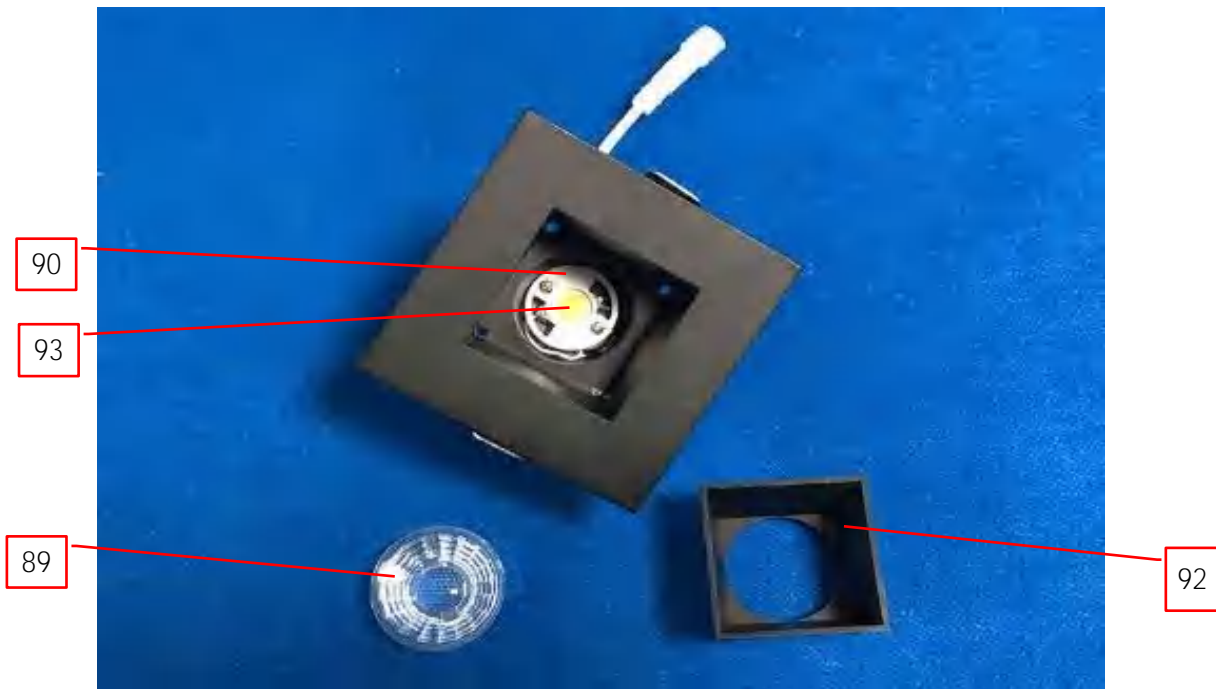


**Photo 150e** - Alternative external view of JXL-COB02-S08W-CCT

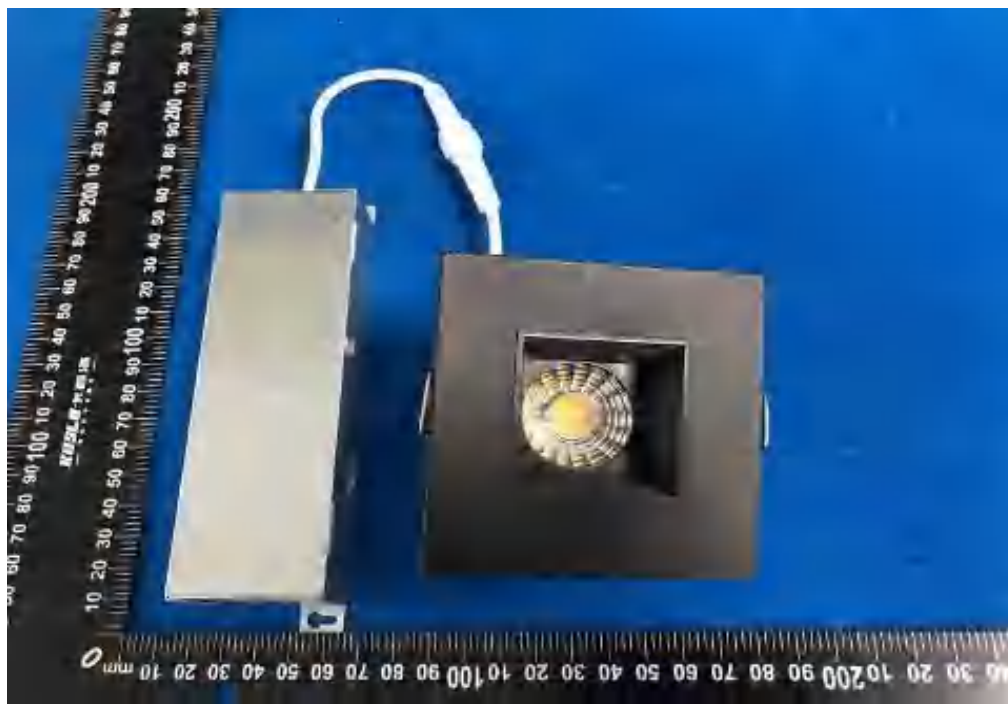


**3.0 Product Photographs**

**Photo 150f** - Alternative internal view of JXL-COB02-S08W-CCT

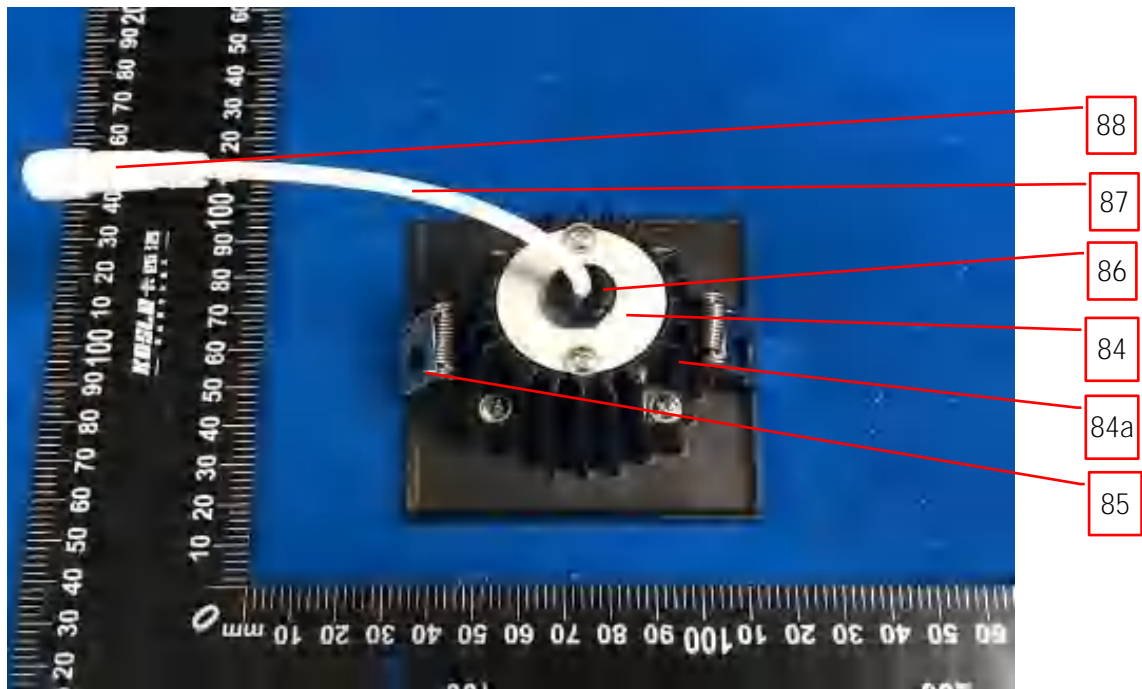


**Photo 150g** - Alternative external view of JXL-COB02-S08W-CCT

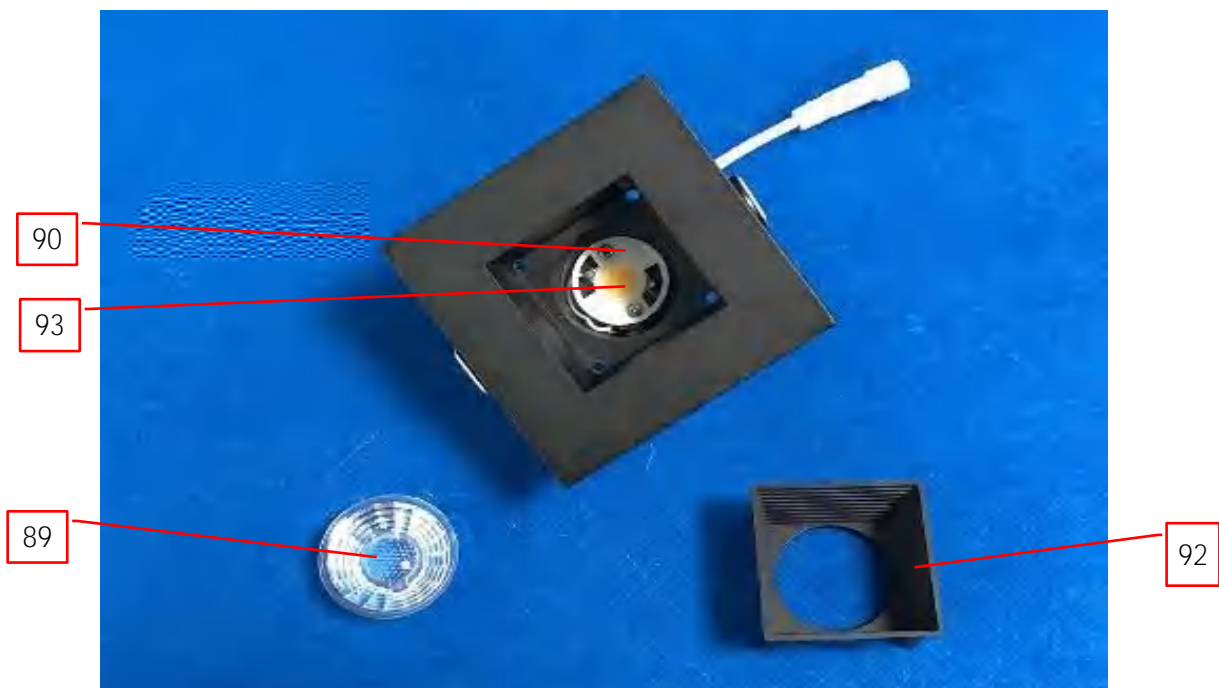


**3.0 Product Photographs**

**Photo 150h** - Alternative external view of JXL-COB02-S08W-CCT



**Photo 150i** - Alternative internal view of JXL-COB02-S08W-CCT

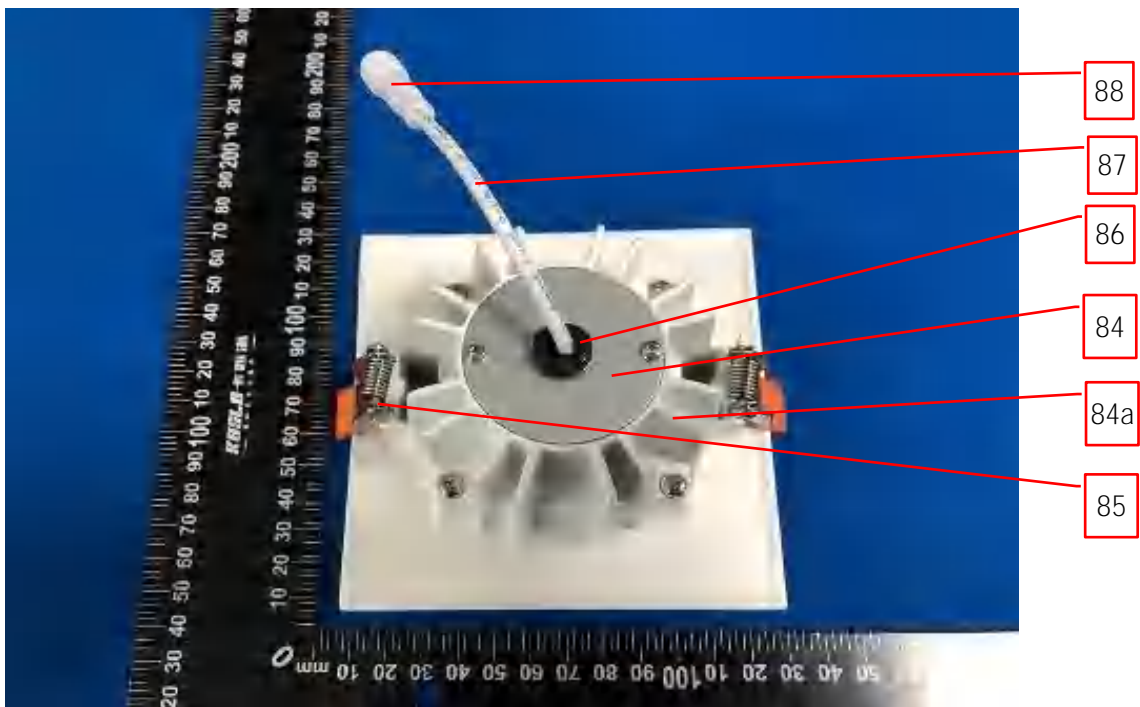


**3.0 Product Photographs**

**Photo 150j** - Alternative external view of JXL-COB04-S15W-CCT

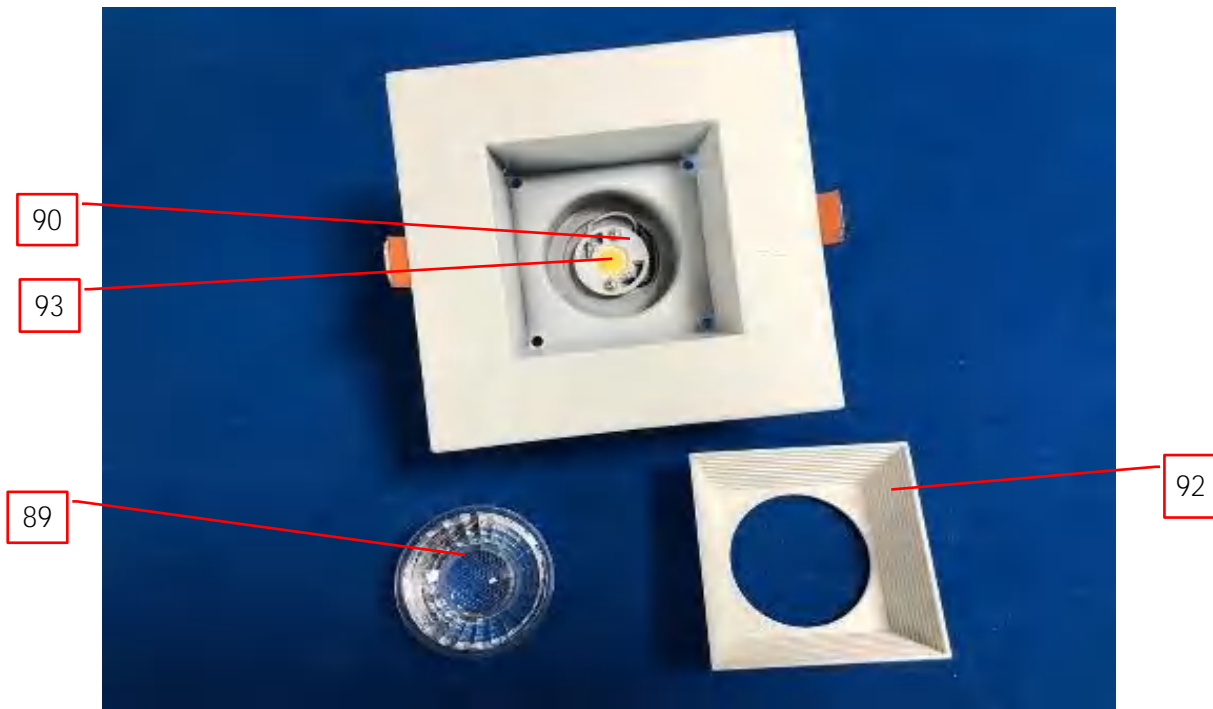


**Photo 150k** - Alternative external view of JXL-COB04-S15W-CCT

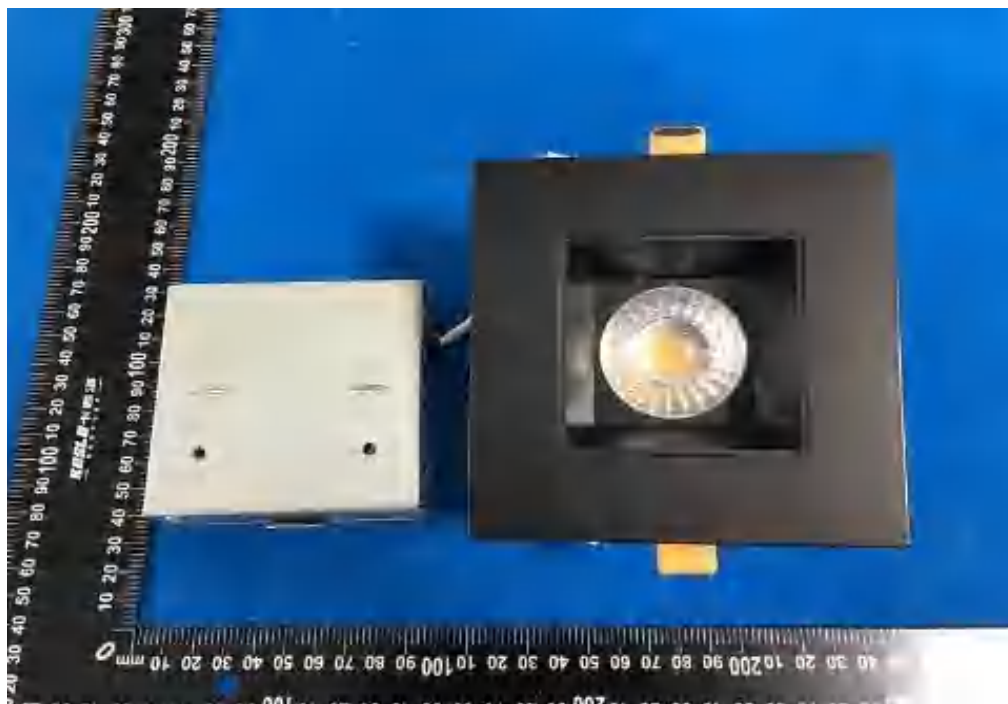


**3.0 Product Photographs**

**Photo 150l** - Alternative internal view of JXL-COB04-S15W-CCT

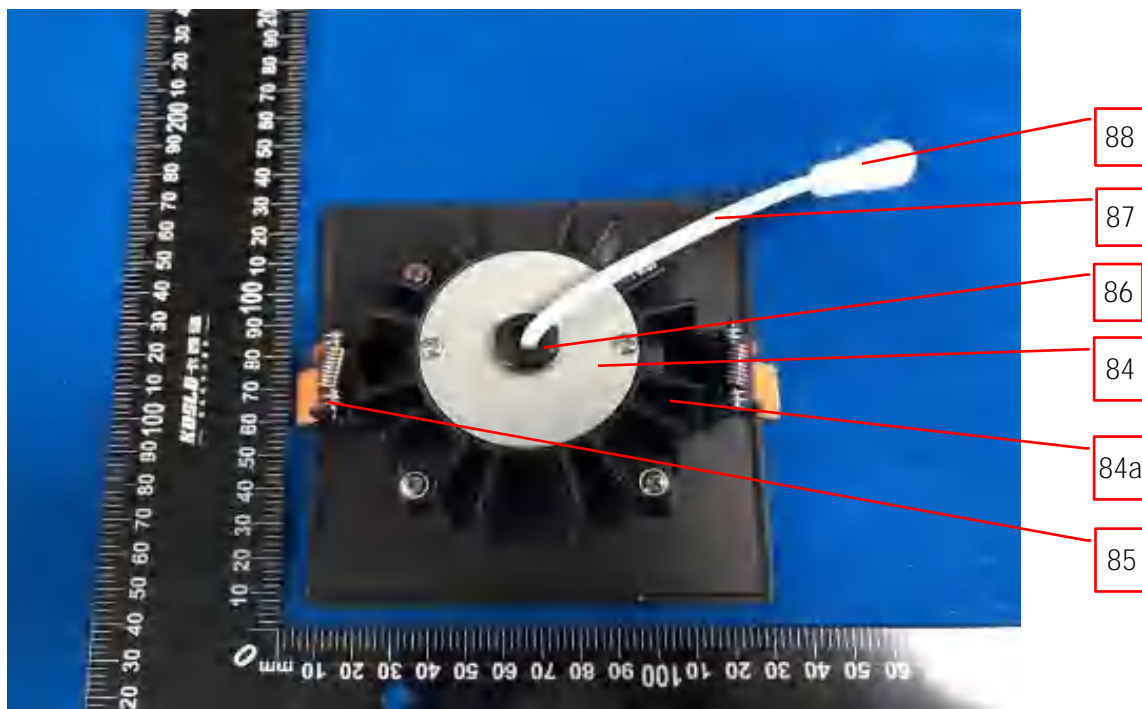


**Photo 150m** - Alternative external view of JXL-COB04-S15W-CCT



**3.0 Product Photographs**

**Photo 150n** - Alternative external view of JXL-COB04-S15W-CCT



**Photo 150o** - Alternative internal view of JXL-COB04-S15W-CCT

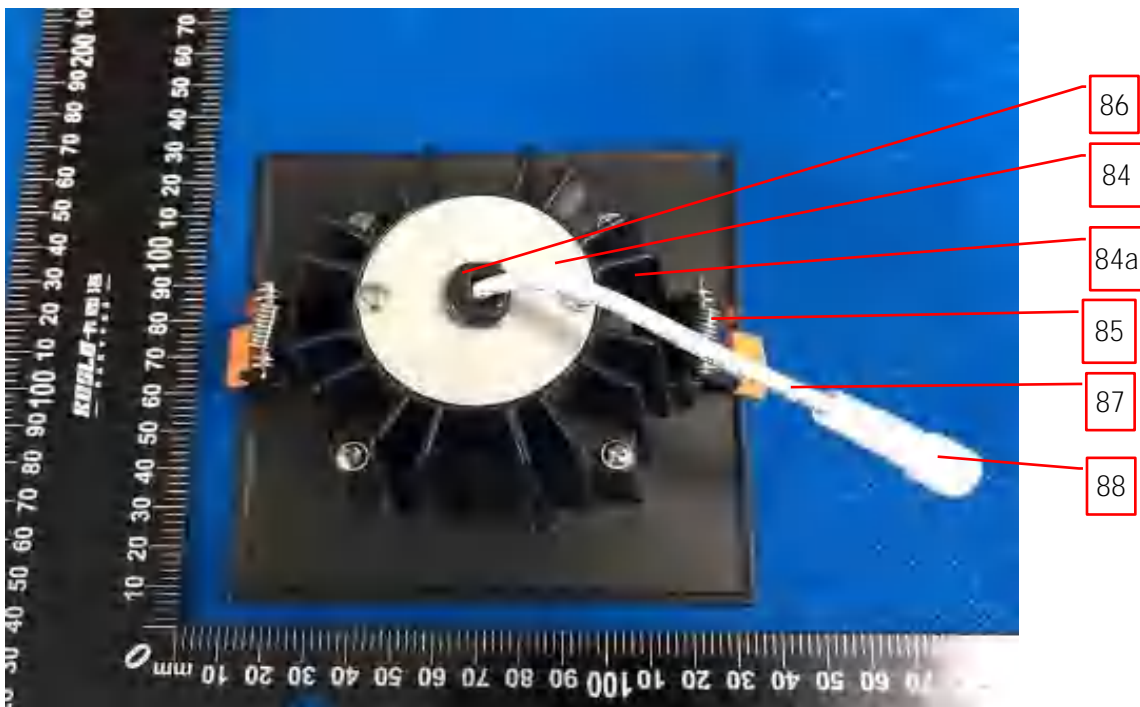


**3.0 Product Photographs**

**Photo 150p** - Alternative external view of JXL-COB04-S15W-CCT

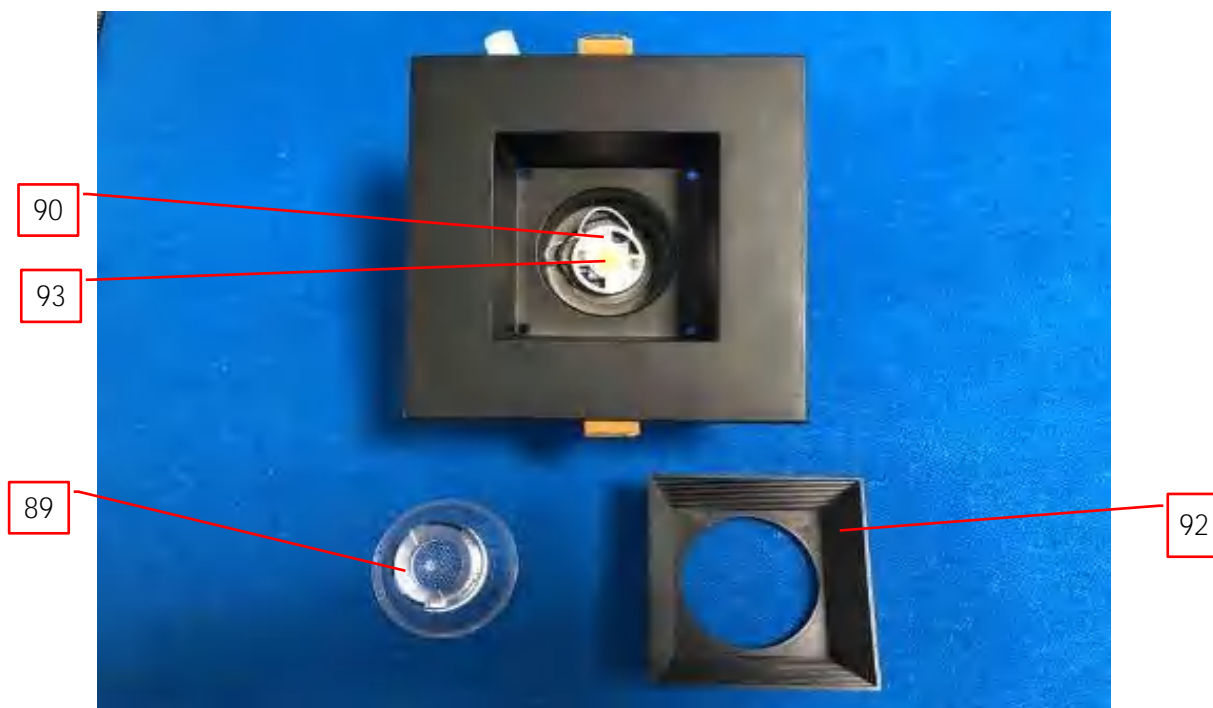


**Photo 150q** - Alternative external view of JXL-COB04-S15W-CCT



**3.0 Product Photographs**

**Photo 150r** - Alternative internal view of JXL-COB04-S15W-CCT



**Photo 151** - External view of JXL-SMD04-G10W-CCT (Group 3)



### 3.0 Product Photographs

**Photo 152** - External view of JXL-SMD04-G10W-CCT (Group 3)



**Photo153** - External view of JXL-SMD04-G10W-CCT (Group 3)



### 3.0 Product Photographs

**Photo 154** - Internal view of LED Panel for model JXL-SMD04-G10W-CCT (Group 3)



**Photo 155** - External view of JXL-COB04-G10W-CCT (Group 4)



**3.0 Product Photographs**

**Photo156** - External view of JXL-COB04-G10W-CCT (Group 4)

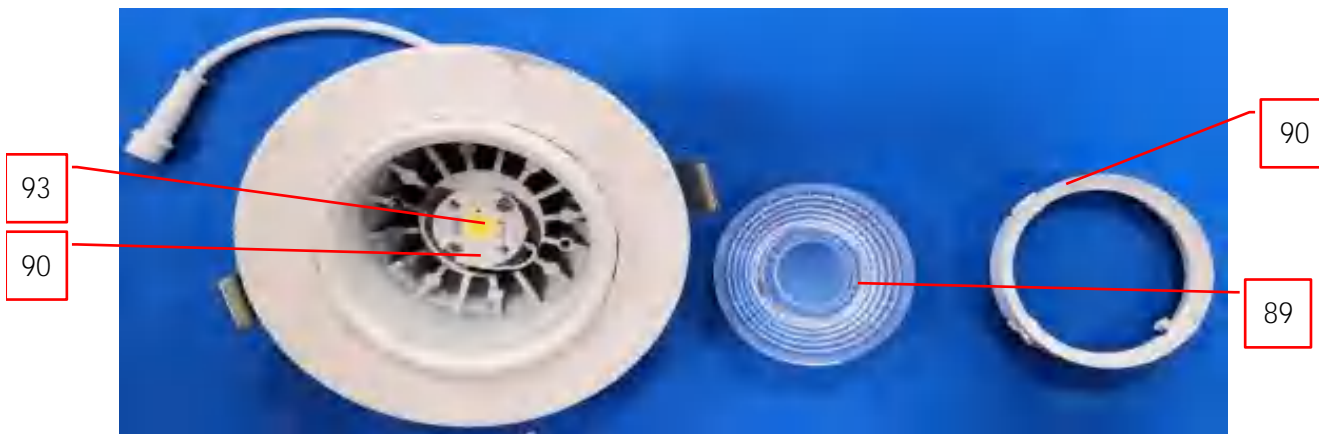


**Photo157** - External view of JXL-COB04-G10W-CCT (Group 4)



**3.0 Product Photographs**

**Photo158** - Internal view of LED Panel for model JXL-COB04-G10W-CCT (Group 4)



**Photo 159** - External view of JXL-TE04-T12W-UDN-XX, JXL-TEH04-T12W-UDN -XX (Group 5)



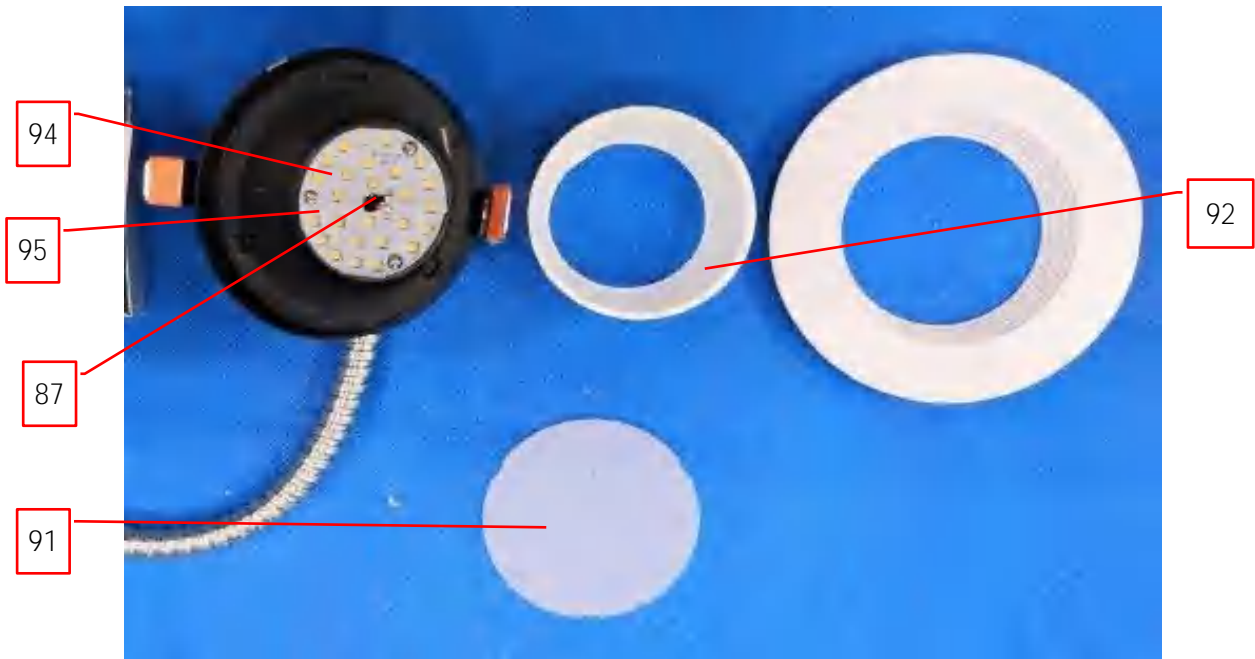
### 3.0 Product Photographs

**Photo 160** - External view of JXL-TE04-T12W-UDN-XX, JXL-TEH04-T12W-UDN-XX (Group 5)

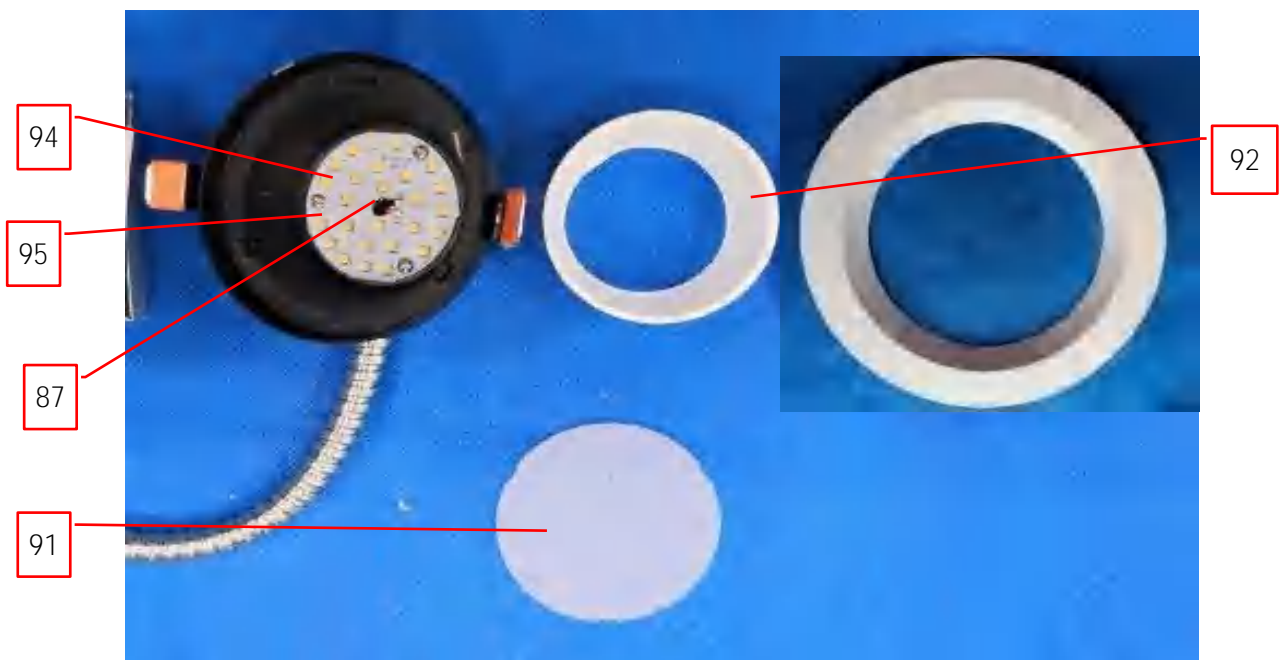


**3.0 Product Photographs**

**Photo 162** - Internal view of LED Panel for mode JXL-TE04-T12W-UDN-XX, JXL-TEH04-T12W-UDN-XX (Group 5)

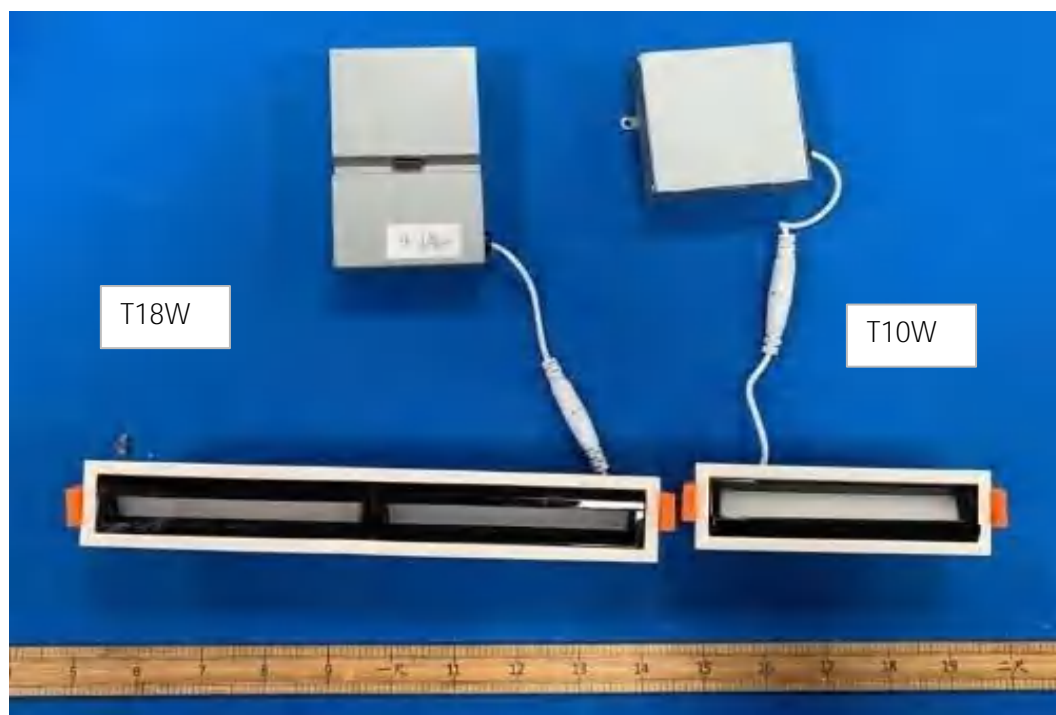


**Photo 162a** - Internal view of LED Panel (with alternative lamp trim) for model JXL-TE04-T12W-UDN-XX, JXL-TEH04-T12W-UDN-XX (Group 5)

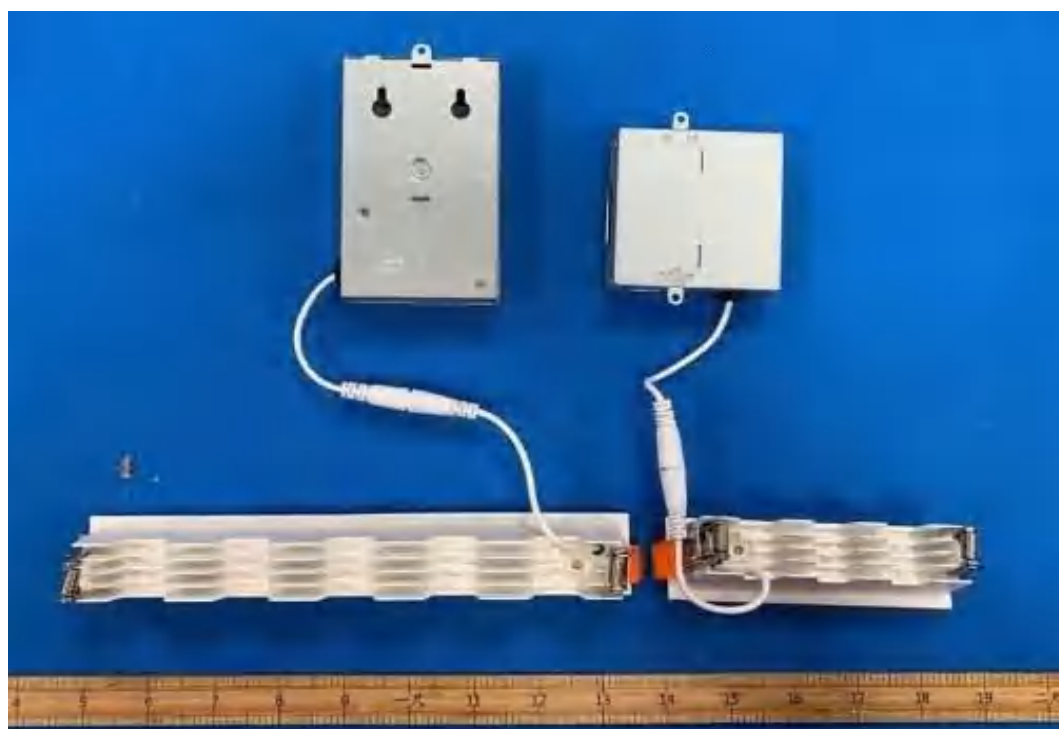


### 3.0 Product Photographs

**Photo 167** - External view of JXL-TX05-T10W-UDN-XX, JXL-TX10-T18W-UDN-XX (Group 7)

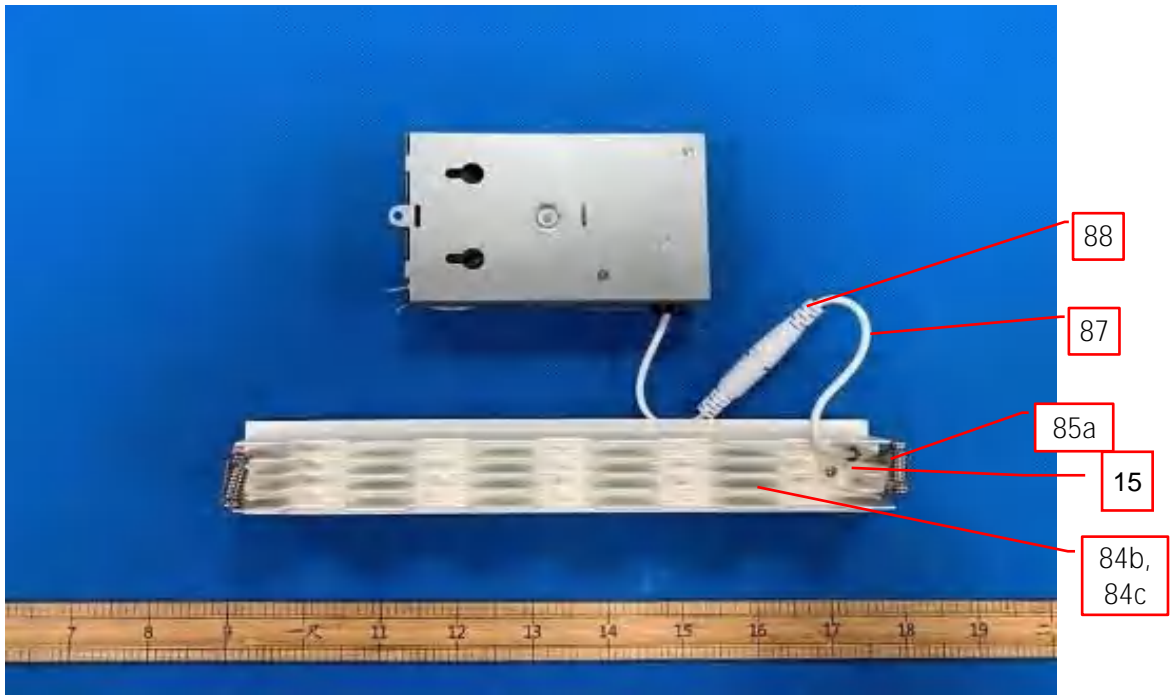


**Photo 168** - External view of JXL-TX05-T10W-UDN-XX, JXL-TX10-T18W-UDN-XX (Group 7)



**3.0 Product Photographs**

**Photo 169** - External view of JXL-TX10-T18W-UDN-XX, also represent JXL-TX05-T10W-UDN-XX (Group 7)



**Photo 170** - Internal view of JXL-TX10-T18W-UDN-XX, also represent JXL-TX05-T10W-UDN-XX (Group 7)

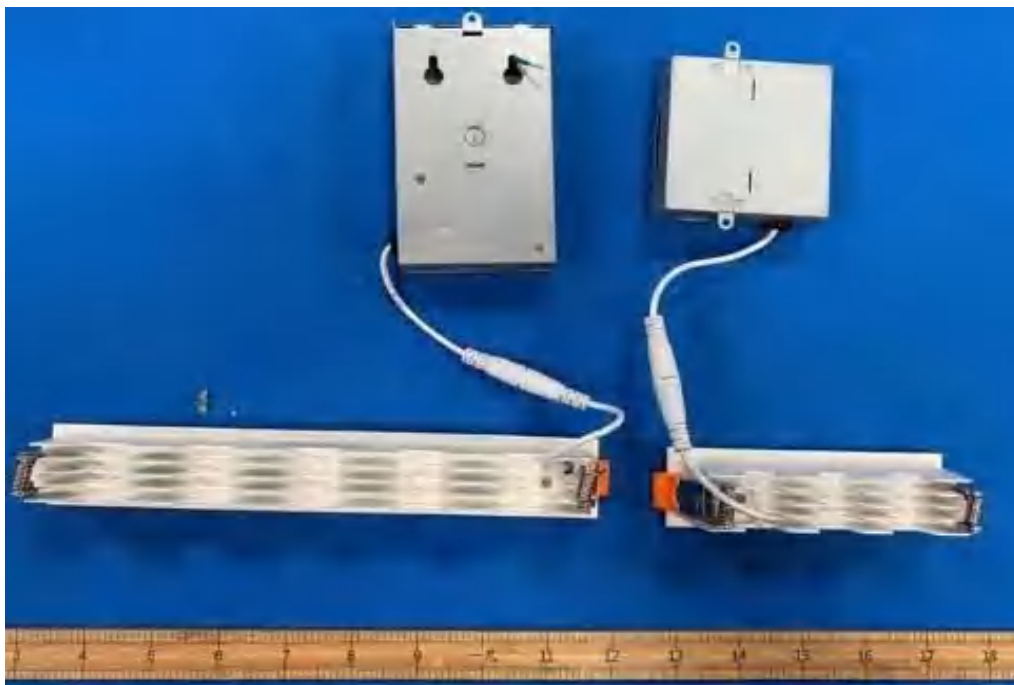


**3.0 Product Photographs**

**Photo 171** - External view of JXL-TXH10-T18W-UDN-XX, JXL-TXH05-T10W-UDN-XX Series (Group 8)

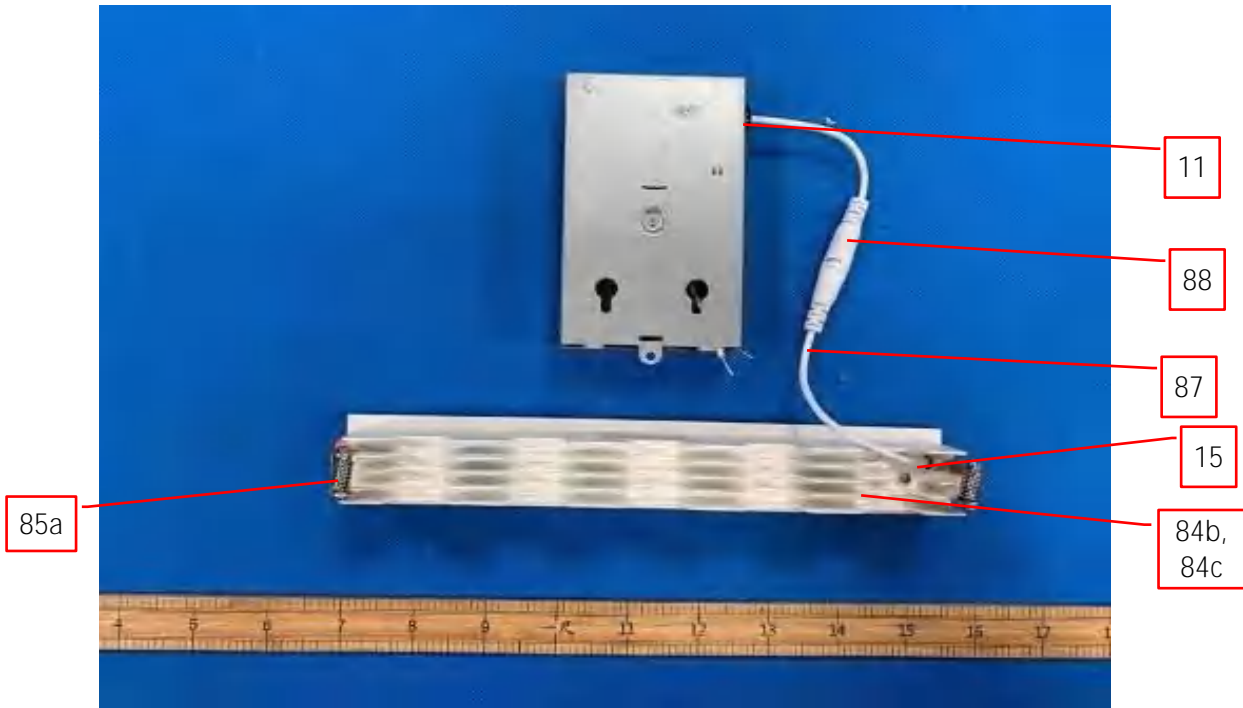


**Photo 172** - External view of JXL-TXH10-T18W-UDN-XX, JXL-TXH05-T10W-UDN-XX Series (Group 8)



**3.0 Product Photographs**

**Photo 173** - External view of JXL-TXH10-T18W-UDN-XX, also represent JXL-TXH05-T10W-UDN-XX Series (Group 8)



**Photo 174** - Internal view of LED Panel for model JXL-TXH10-T18W-UDN-XX, also represent JXL-TXH05-T10W-UDN-XX Series (Group 8)



**3.0 Product Photographs**

**Photo 175** - External view of JXL-TZ04-T10W-UDN-XX, JXL-TZ06-T12W-UDN-XX, JXL-CA04-T10W-UDN-XX, JXL-CA06-T12W-UDN-XX, JXL-TZ04-R10W-CCT, JXL-TZ06-R12W-CCT, JXL-CA04-T10W-CCT, JXL-CA06-T12W-CCT (Group 9)

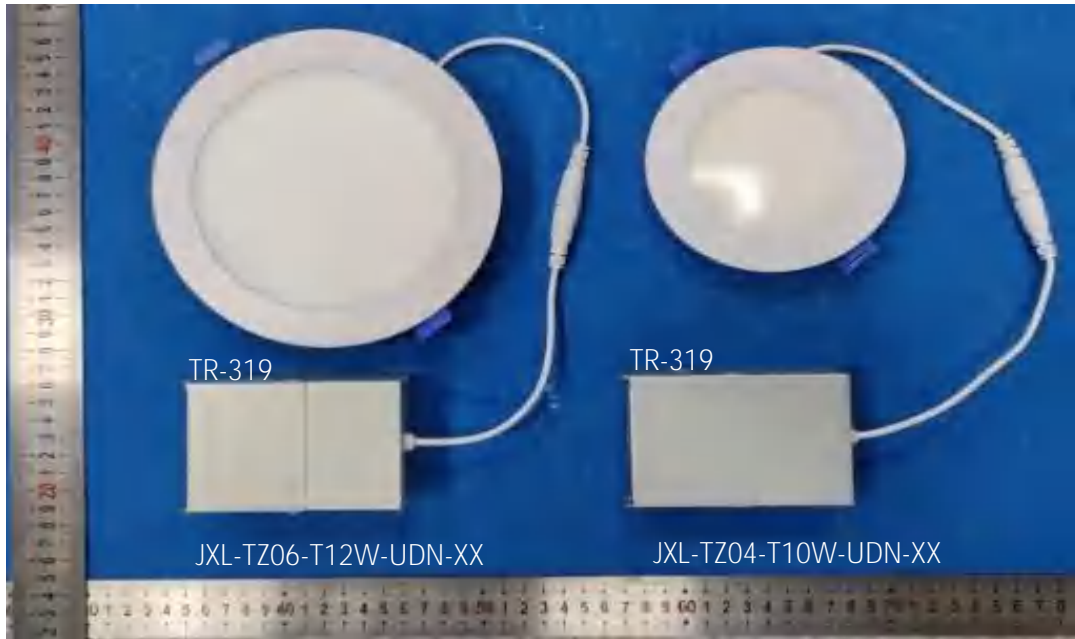


**Photo 176** - External view of JXL-TZ04-T10W-UDN-XX, JXL-TZ06-T12W-UDN-XX, JXL-CA04-T10W-UDN-XX, JXL-CA06-T12W-UDN-XX, JXL-TZ04-R10W-CCT, JXL-TZ06-R12W-CCT, JXL-CA04-T10W-CCT, JXL-CA06-T12W-CCT (Group 9)



**3.0 Product Photographs**

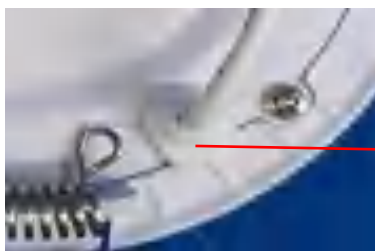
**Photo 176a** - External Top View of models JXL-TZ04-T10W-UDN-XX and JXL-TZ06-T12W-UDN-XX with Alternative LED driver of model TR-319



**Photo 176b** - External Bottom View of models JXL-TZ04-T10W-UDN-XX and JXL-TZ06-T12W-UDN-XX with Alternative LED driver of model TR-319



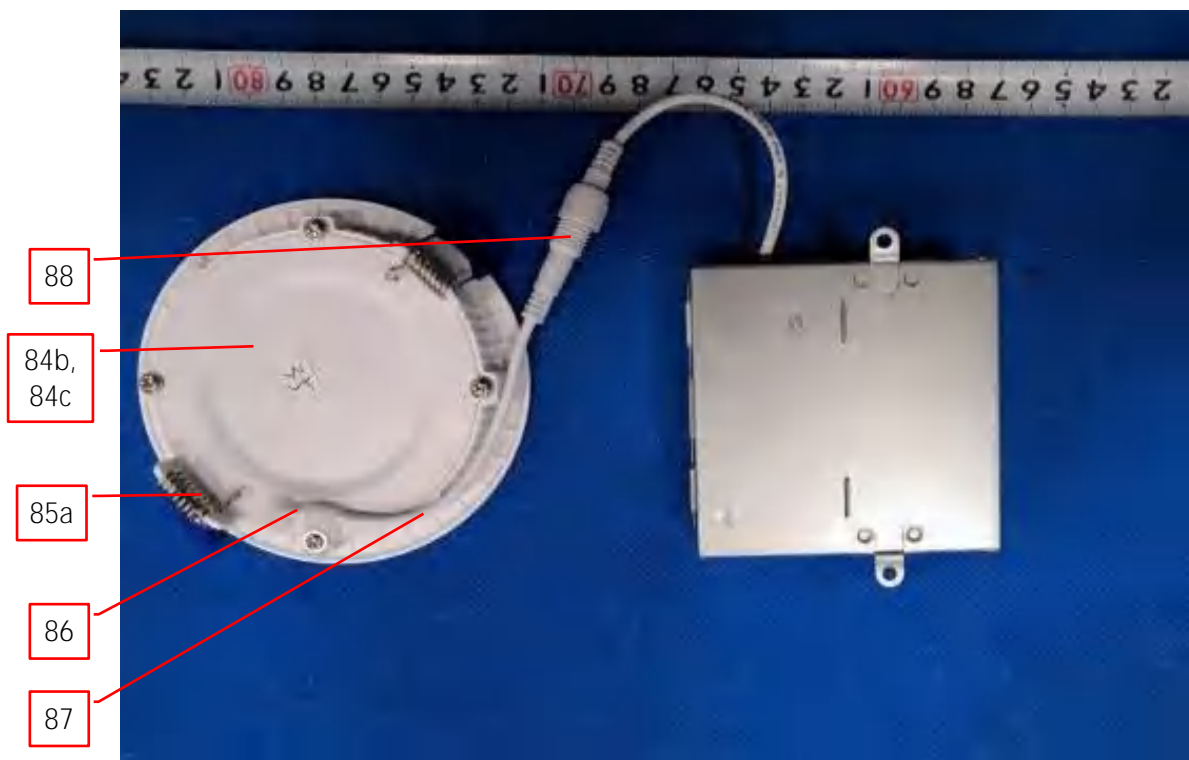
**Photo 176c** - Alternative strain relief device for model JXL-TZ04-T10W-UDN-XX, JXL-TZ06-T12W-UDN-XX, JXL-TZ04-T10W-5CCT, JXL-TZ06-T12W-5CCT, JXL-CA04-T10W-5CCT and JXL-CA06-T12W-5CCT



86

**3.0 Product Photographs**

**Photo 177** - External view of JXL-CA04-T10W-CCT, also represent JXL-TZ04-T10W-UDN-XX, JXL-TZ06-T12W-UDN-XX, JXL-CA04-T10W-UDN-XX, JXL-CA06-T12W-UDN-XX, JXL-TZ04-R10W-CCT, JXL-TZ06-R12W-CCT, JXL-CA06-T12W-CCT (Group 9)

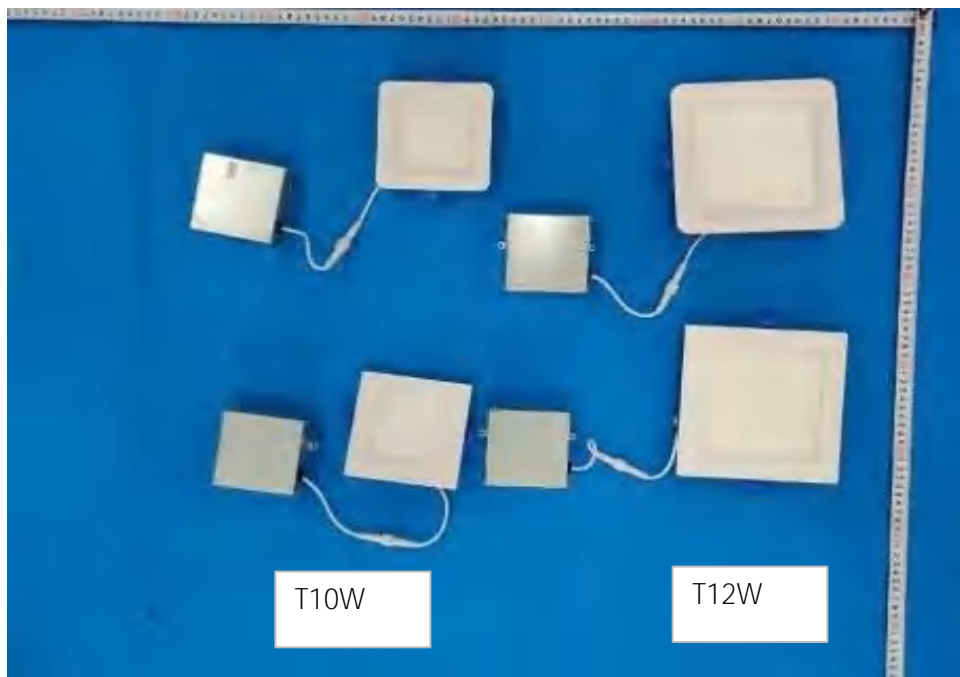


**Photo 178** - Internal view of LED Panel for model JXL-CA04-T10W-CCT, also represent JXL-TZ04-T10W-UDN-XX, JXL-TZ06-T12W-UDN-XX, JXL-CA04-T10W-UDN-XX, JXL-CA06-T12W-UDN-XX, JXL-TZ04-R10W-CCT, JXL-TZ06-R12W-CCT, JXL-CA06-T12W-CCT (Group 9)

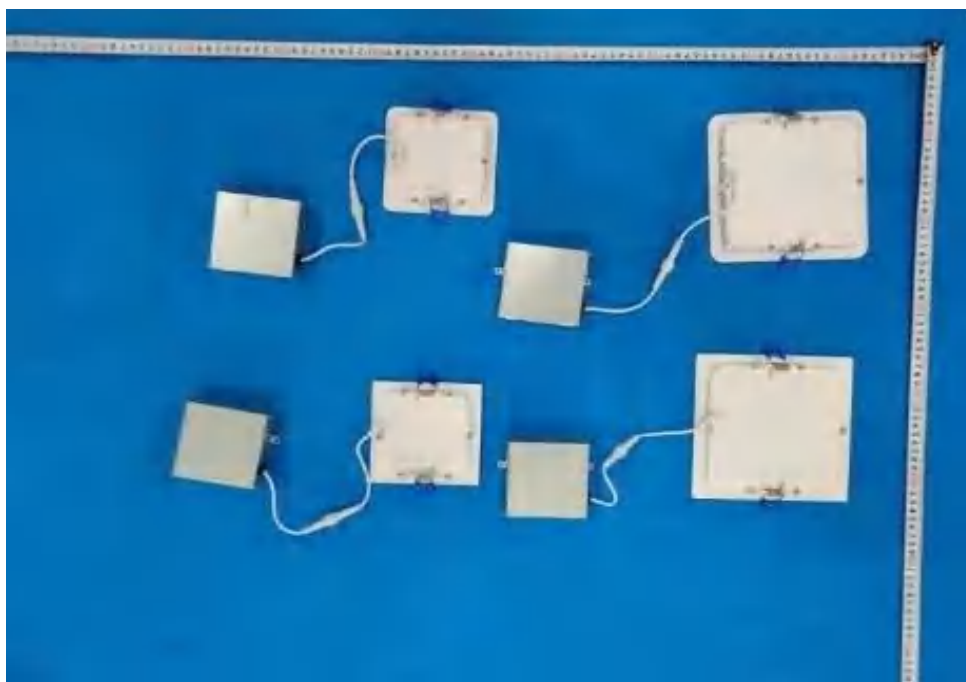


### 3.0 Product Photographs

**Photo 183** - External view of JXL-CM06-T12W-CCT, JXL-CM04-T10W-CCT, JXL-CF04-T10W-CCT, JXL-CF06-T12W-CCT (Group 11)

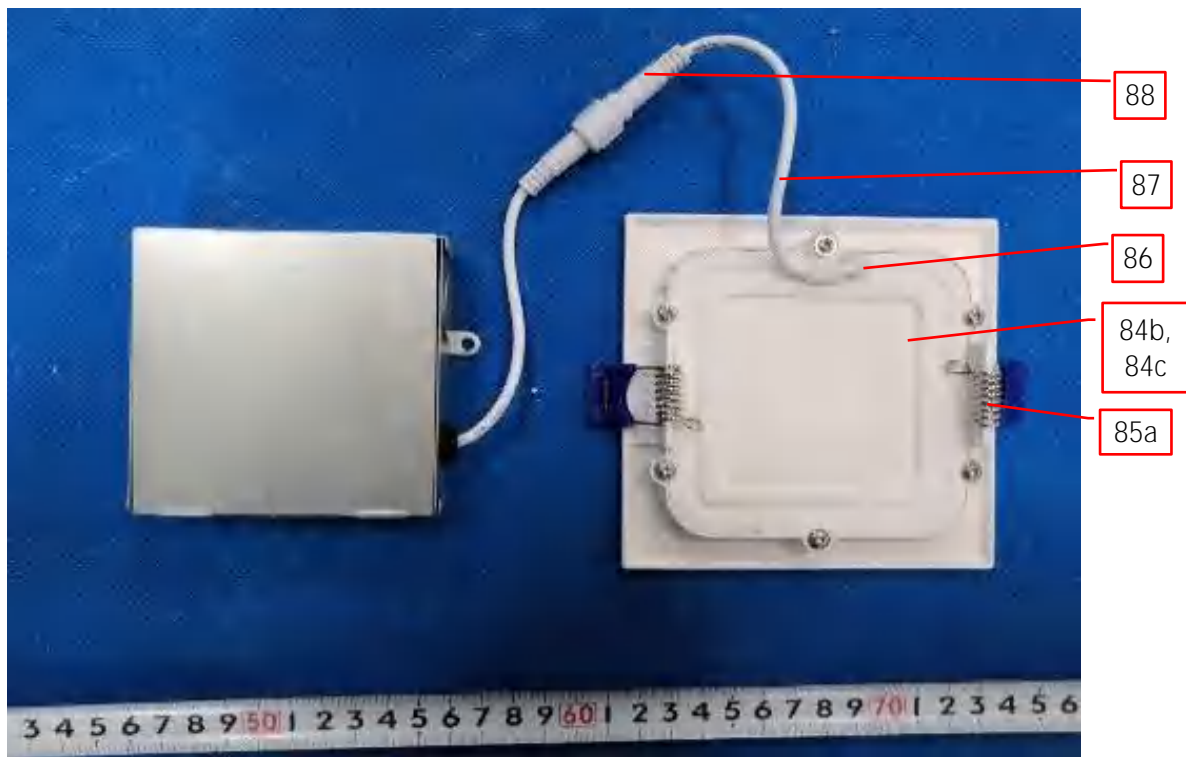


**Photo 184** - External view of JXL-CM06-T12W-CCT, JXL-CM04-T10W-CCT, JXL-CF04-T10W-CCT, JXL-CF06-T12W-CCT (Group 11)



**3.0 Product Photographs**

**Photo 185** - External view of JXL-CM04-T10W-CCT, also represent JXL-CM06-T12W-CCT, JXL-CF04-T10W-CCT, JXL-CF06-T12W-CCT; (Group 11)

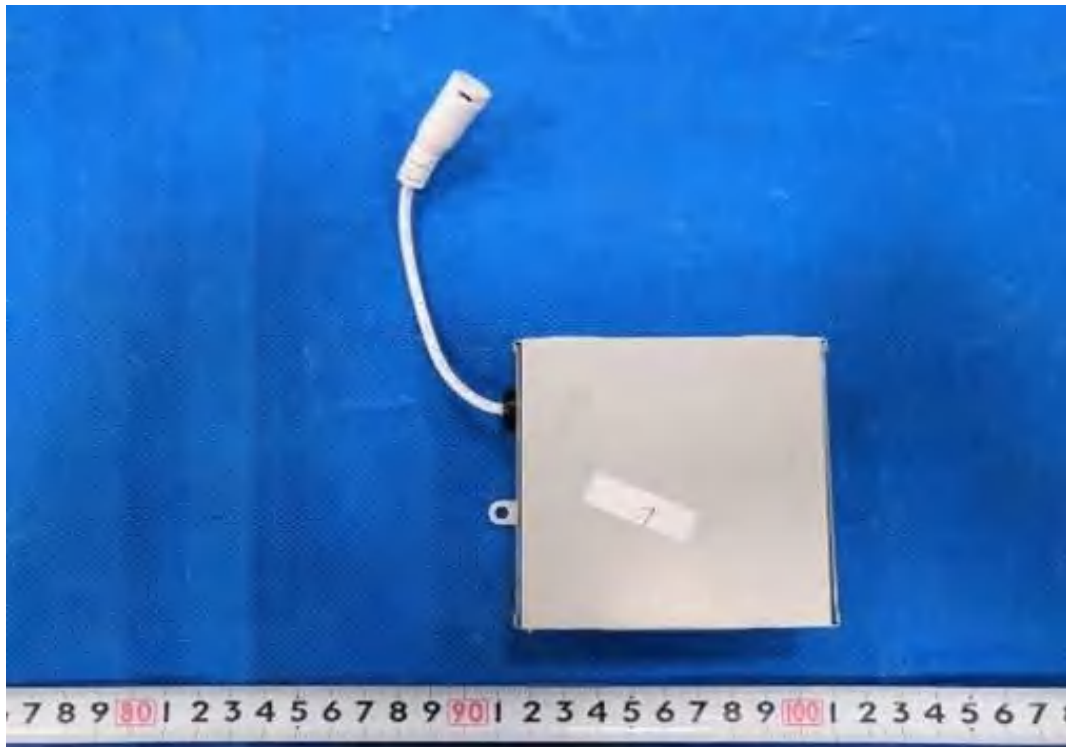


**Photo 186** - Internal view of LED Panel for model JXL-CM04-T10W-CCT, also represent JXL-CM06-T12W-CCT, JXL-CF04-T10W-CCT, JXL-CF06-T12W-CCT; (Group 11)

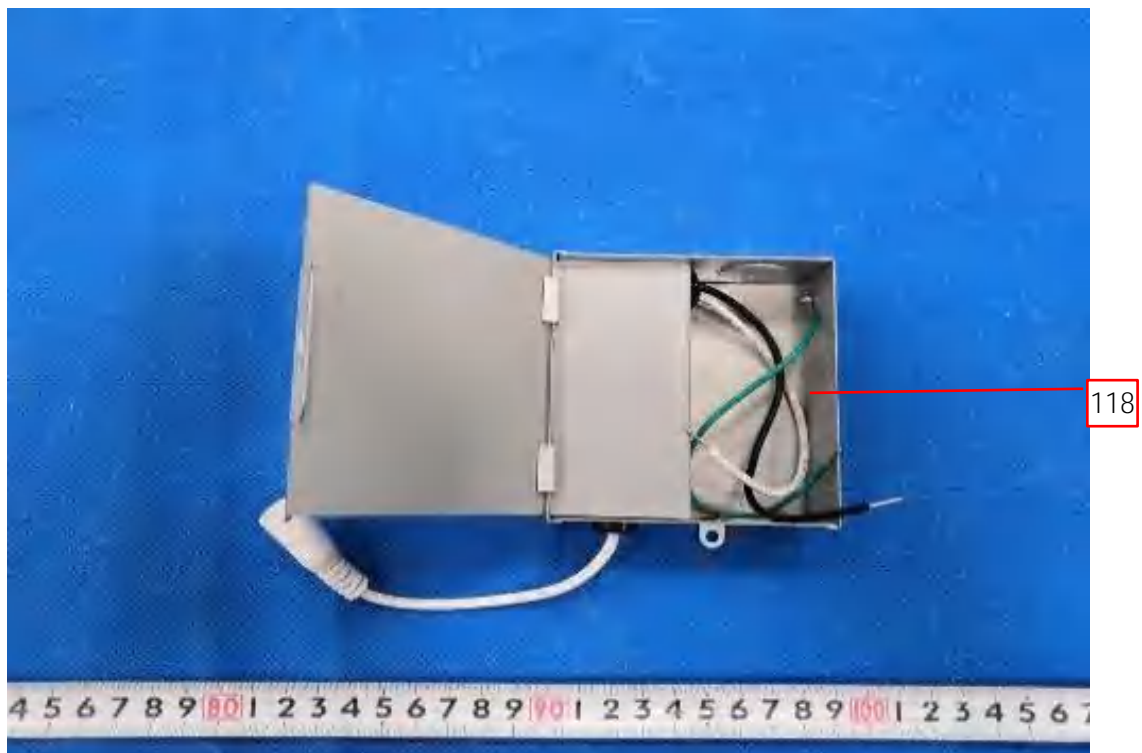


**3.0 Product Photographs**

**Photo 190** - External view of LED Driver TR-023A,TR018-D,TR-019,TR030,TR-012B

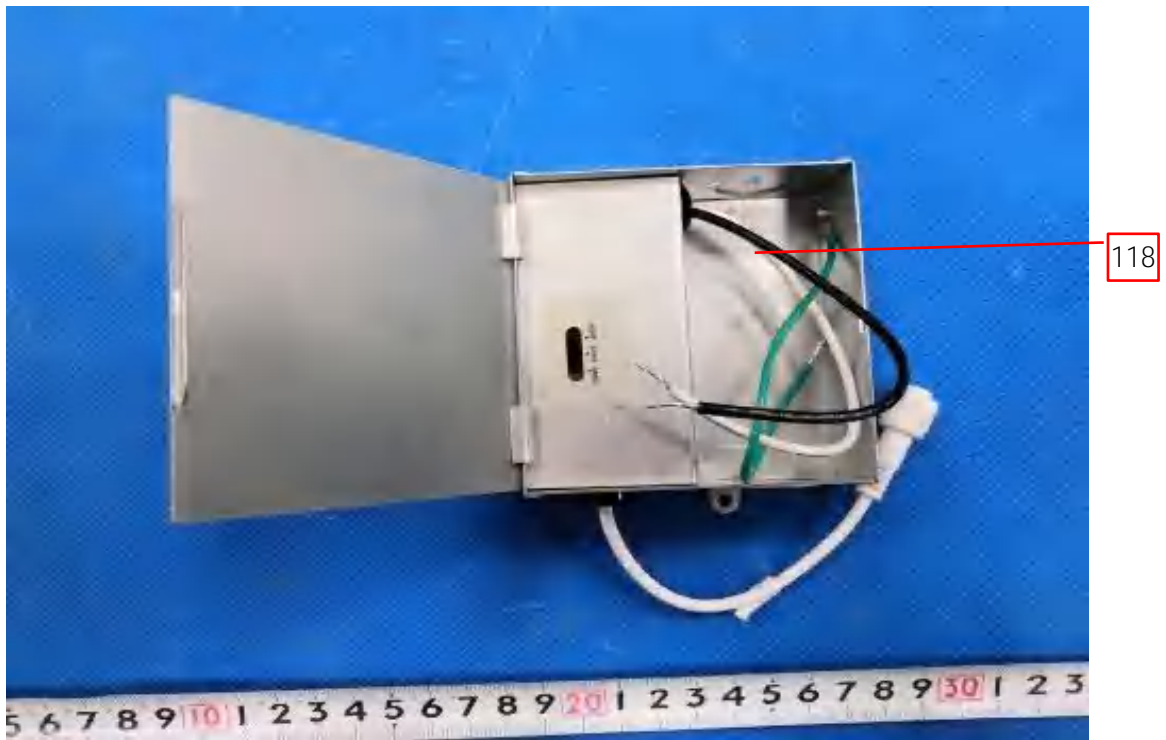


**Photo 191** - Internal view of LED Driver model TR-023A, TR018-D, TR-019, TR030, TR-012B

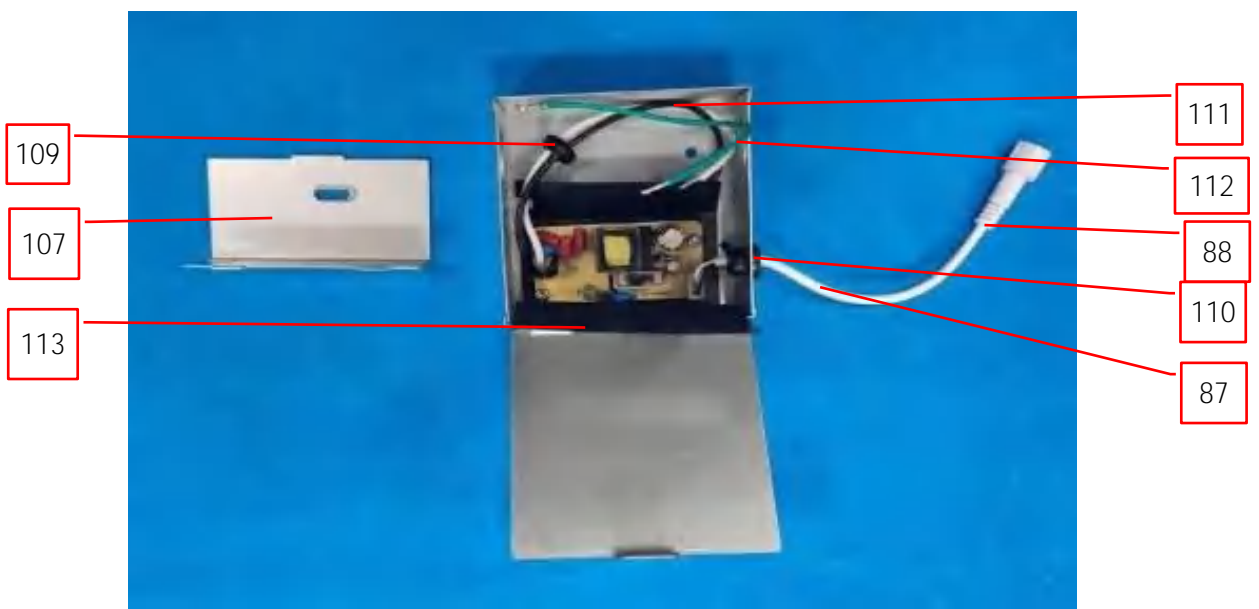


**3.0 Product Photographs**

**Photo 192** - Internal view of LED Driver model TR-012B, TR-030



**Photo 193** - Internal view of LED Driver model TR-012B, also represent TR018-D,TR-019,TR030



**3.0 Product Photographs**

**Photo 194** - Alternative external view of LED Driver model TR-012B and TR-019.



**Photo 195** - Alternative Internal view of LED Driver model TR-019.

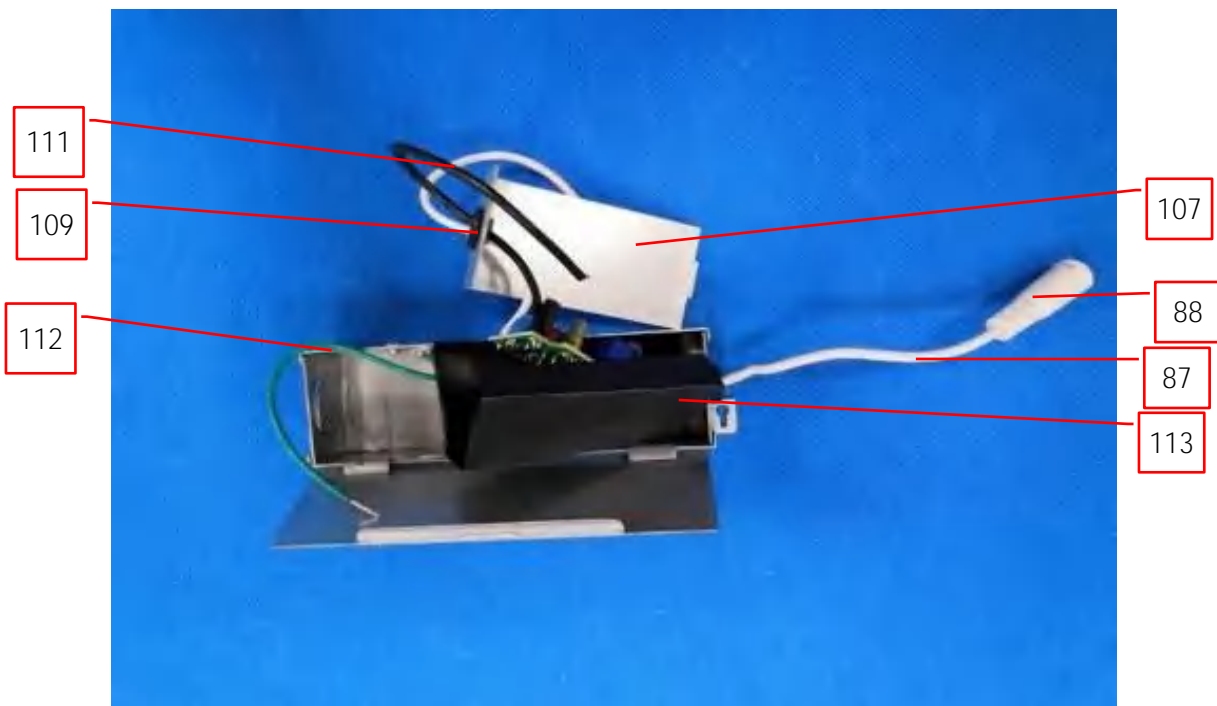


**3.0 Product Photographs**

**Photo 196** - Alternative Internal view of LED Driver model TR-012B.

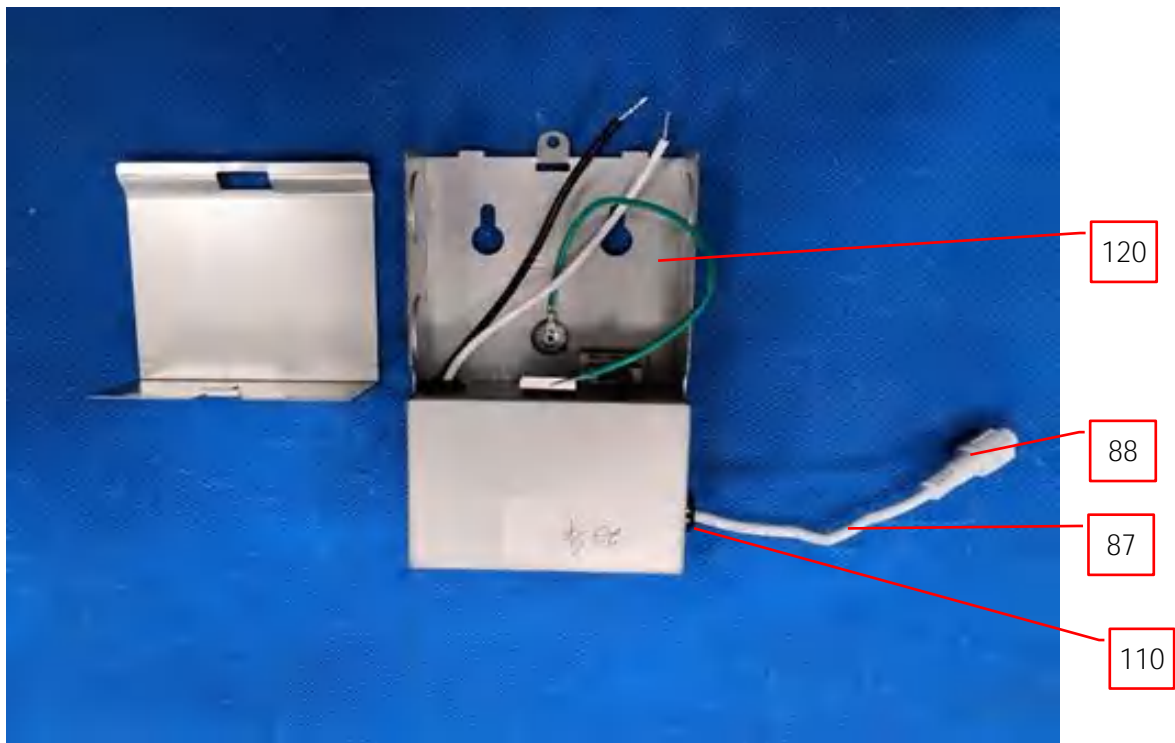


**Photo 196a** - Alternative Internal view of LED Driver model TR-012B and TR-019.

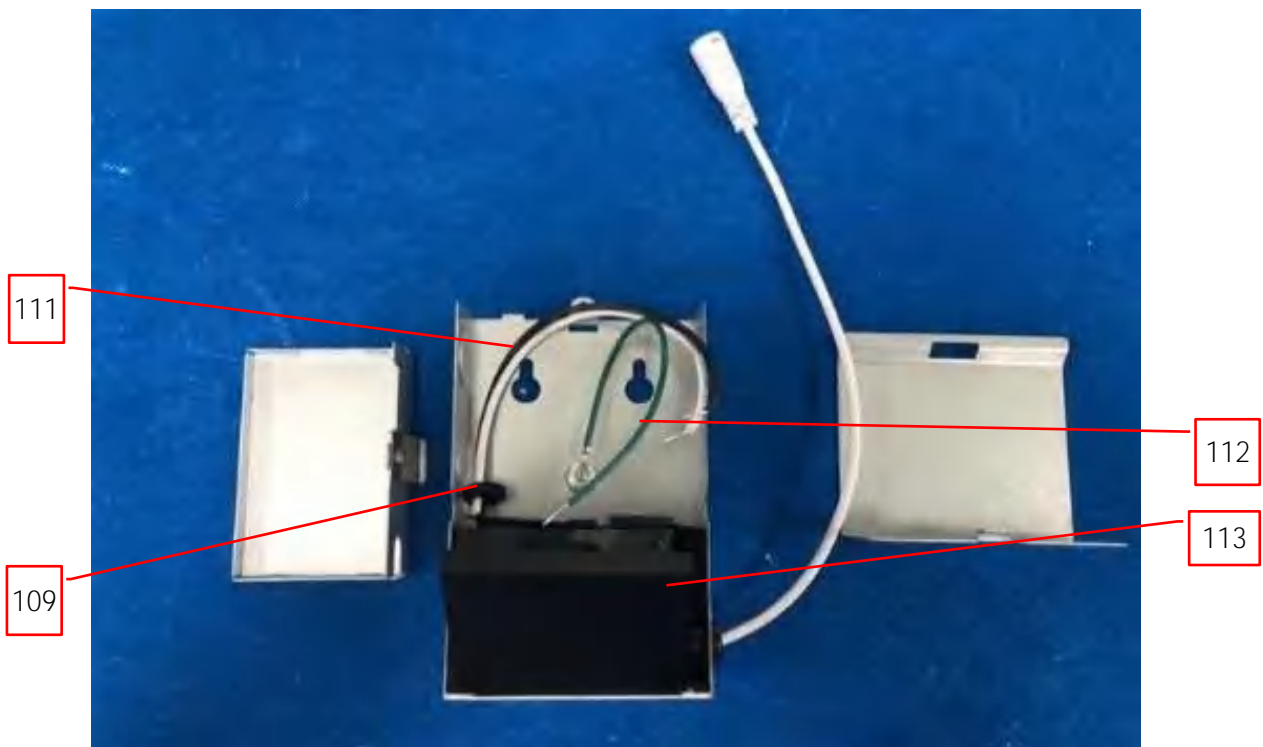


**3.0 Product Photographs**

**Photo 199** - Internal view of LED Driver TR-031A

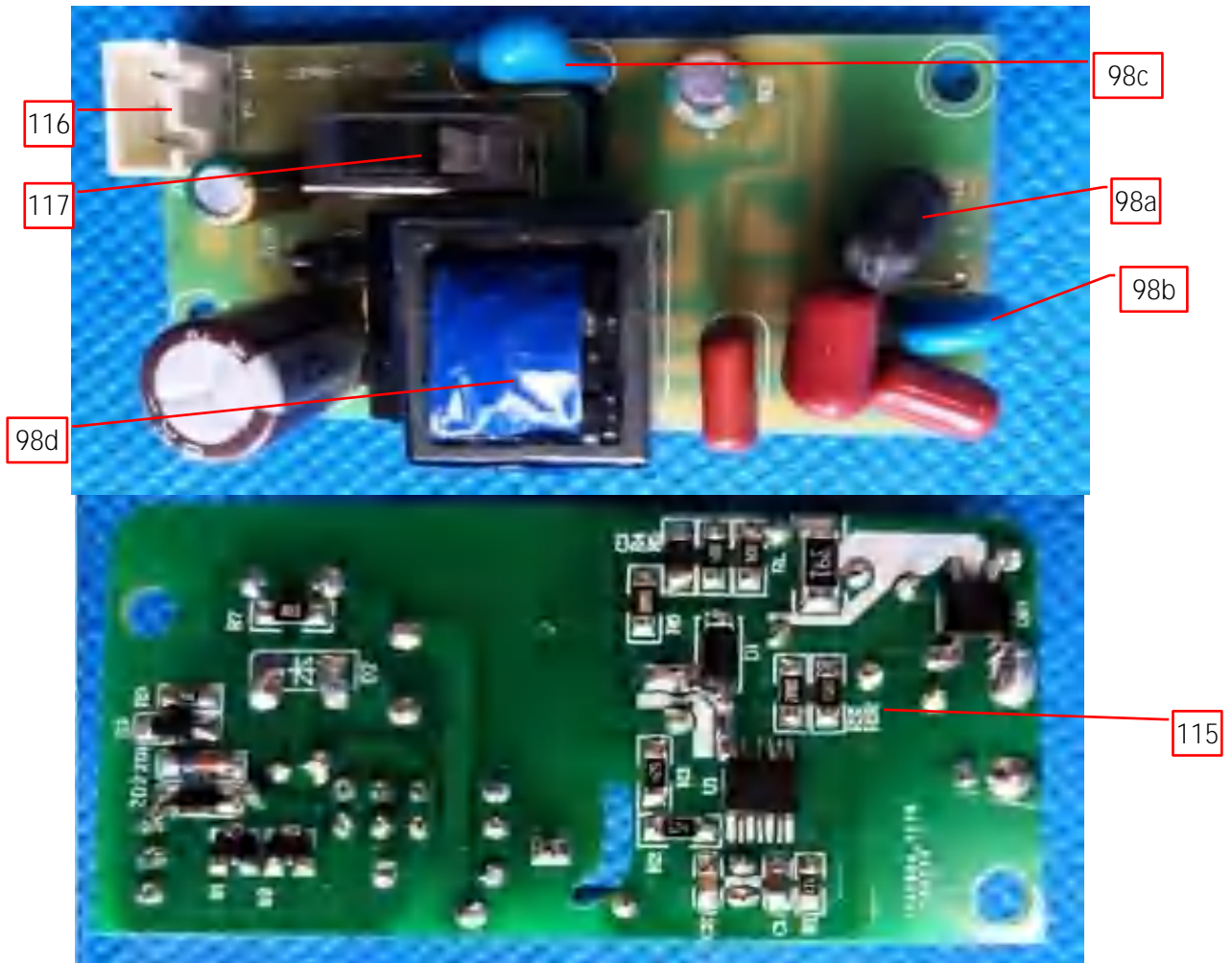


**Photo 199a** - Internal view of LED Driver TR-031A



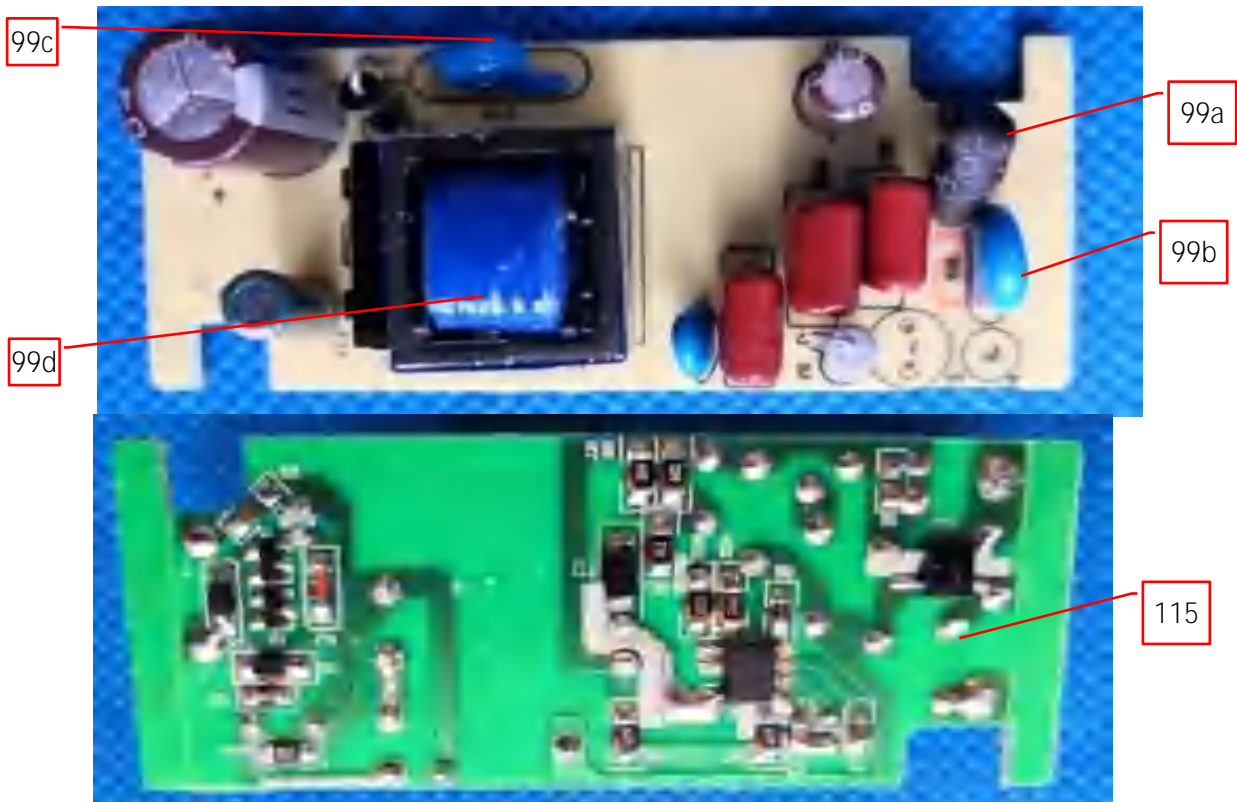
**3.0 Product Photographs**

**Photo 202 - PCB assembly of LED driver model TR-012B**



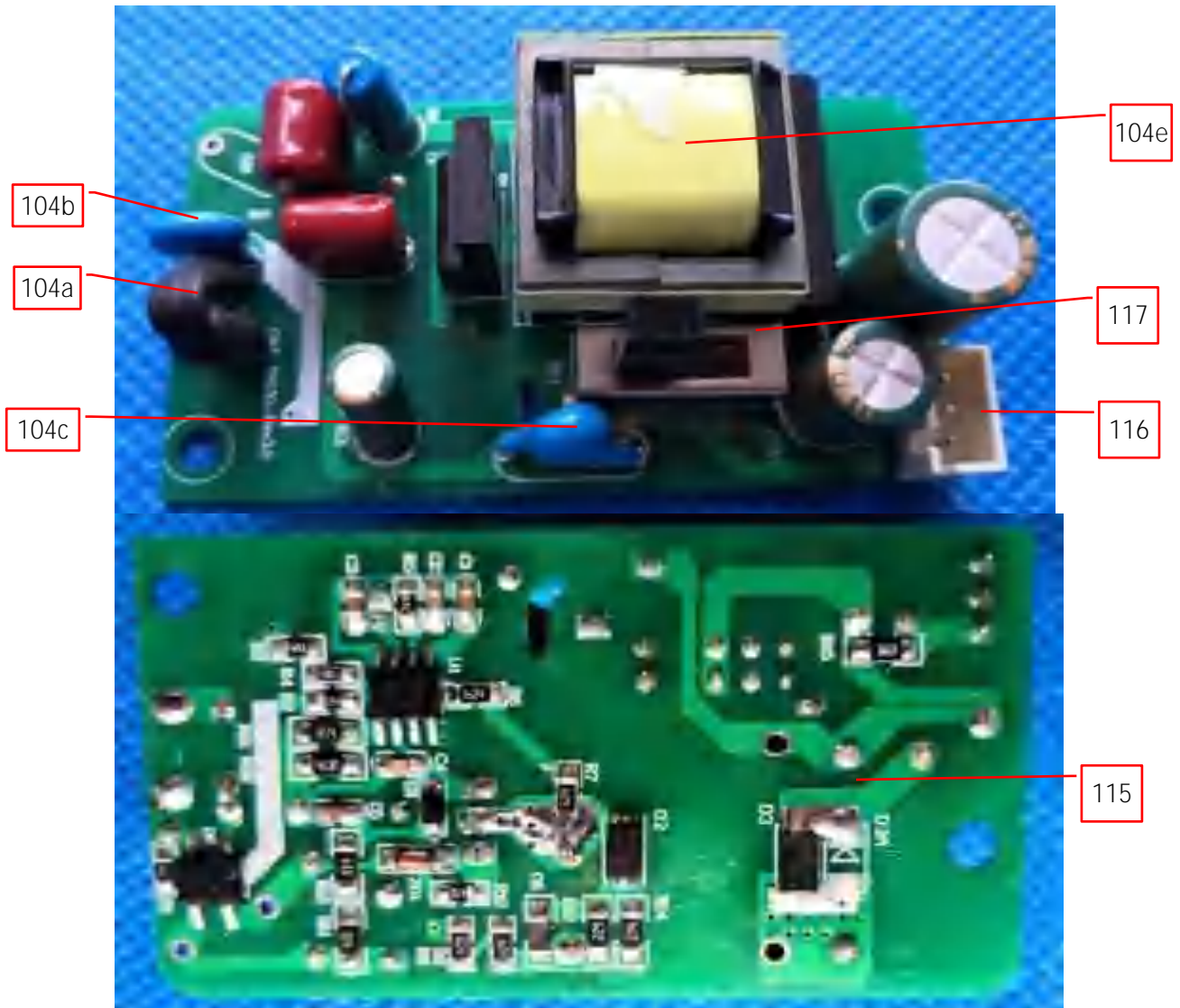
**3.0 Product Photographs**

**Photo 203 - PCB assembly of LED driver model TR-019**



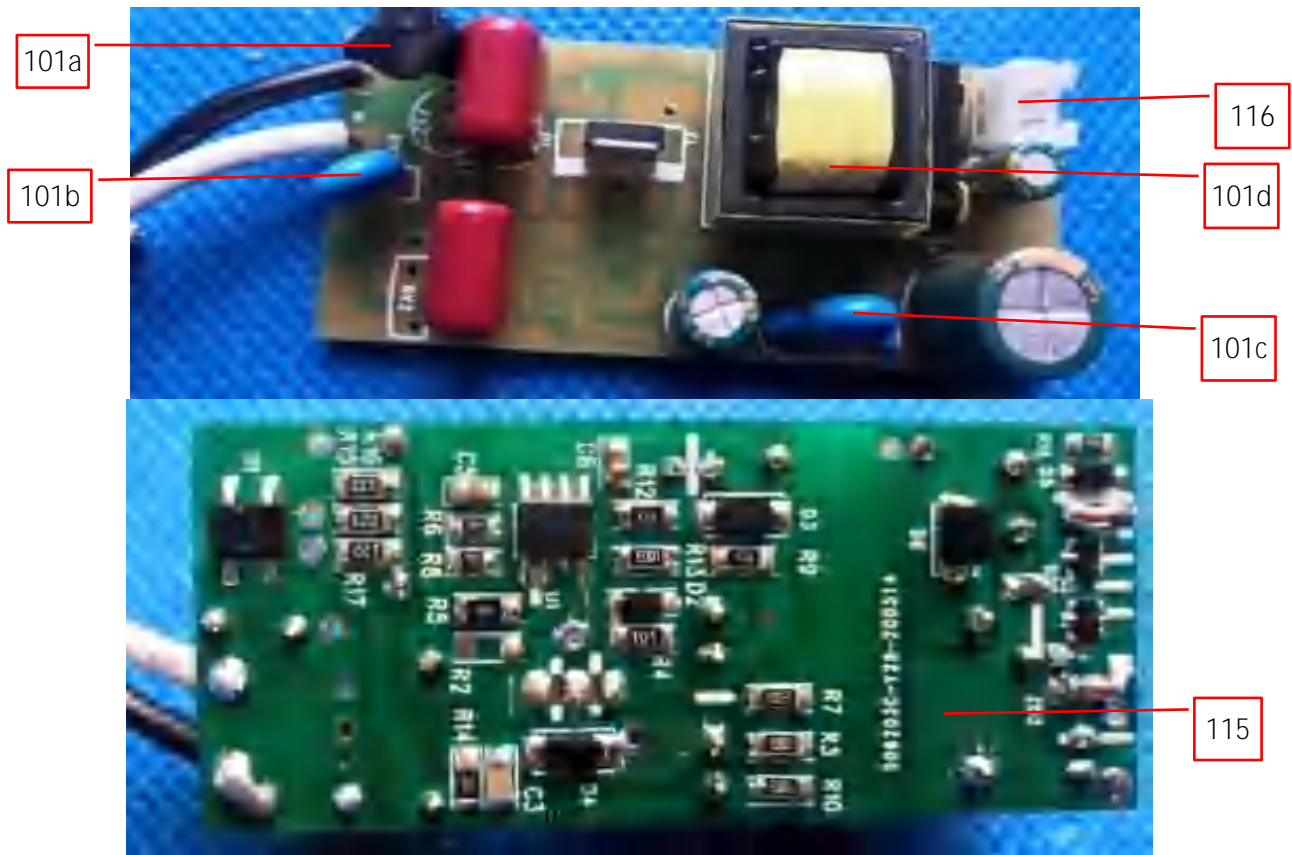
**3.0 Product Photographs**

**Photo 204** - PCB assembly of LED driver model TR-030



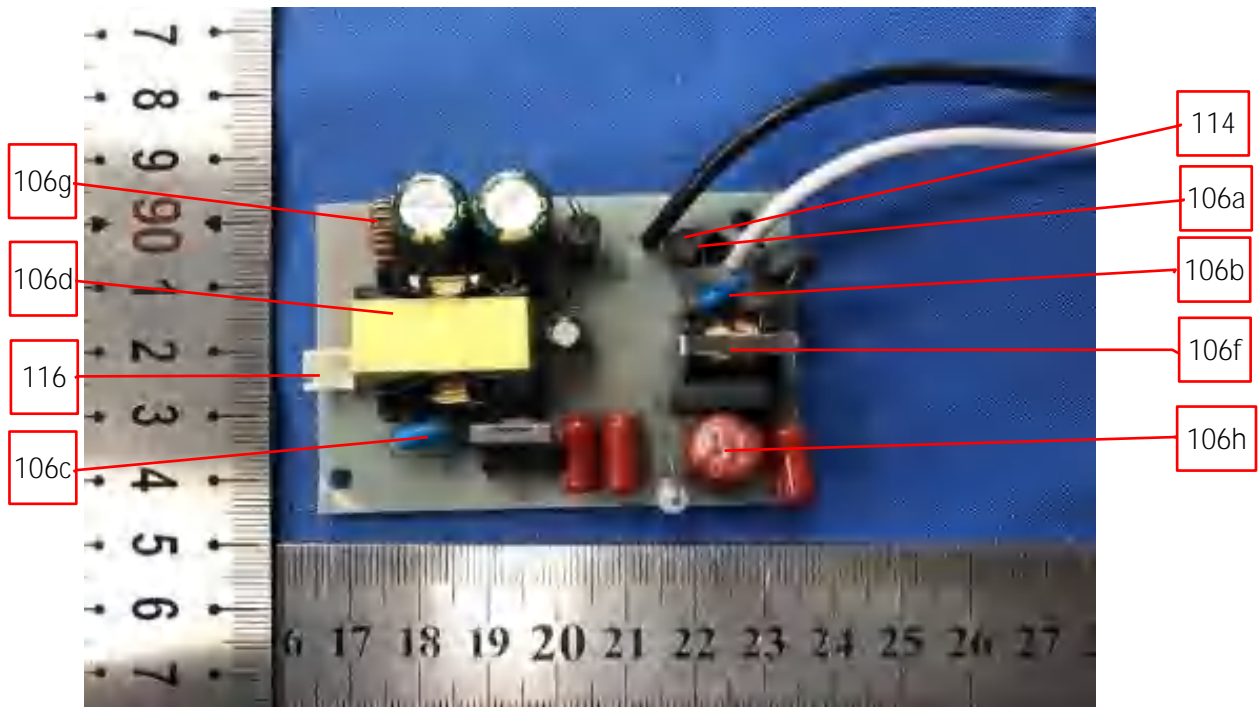
### 3.0 Product Photographs

Photo 205 - PCB assembly of LED driver model TR-023A

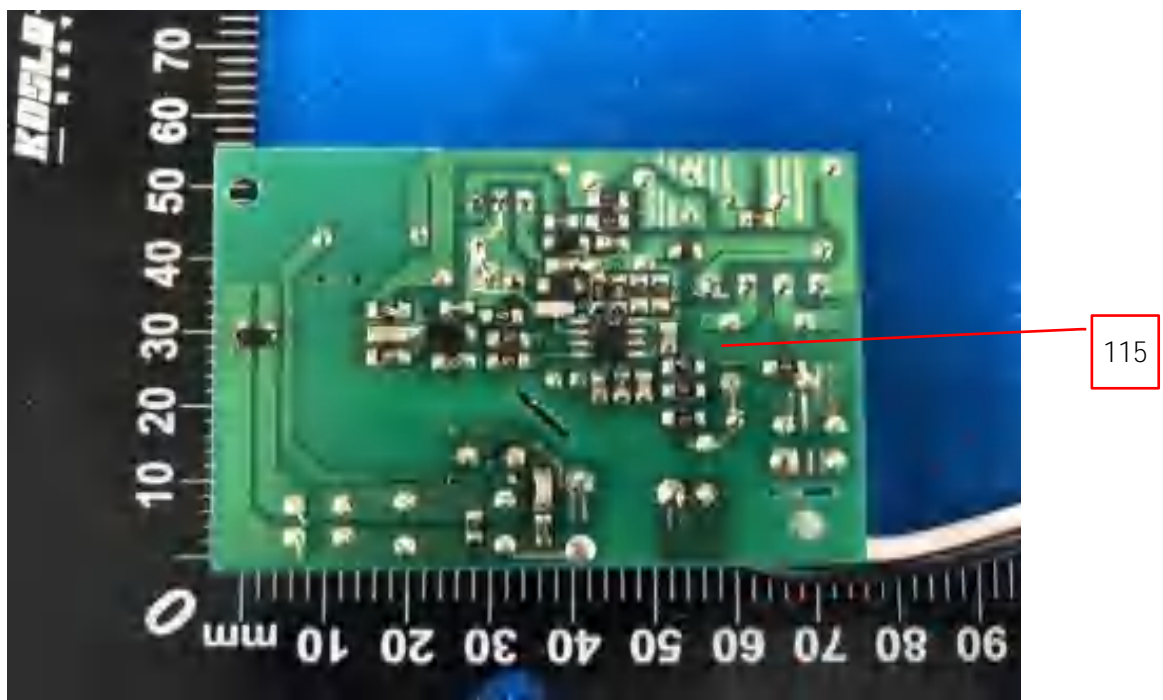


**3.0 Product Photographs**

**Photo 207** - PCB assembly of LED driver model TR-031A

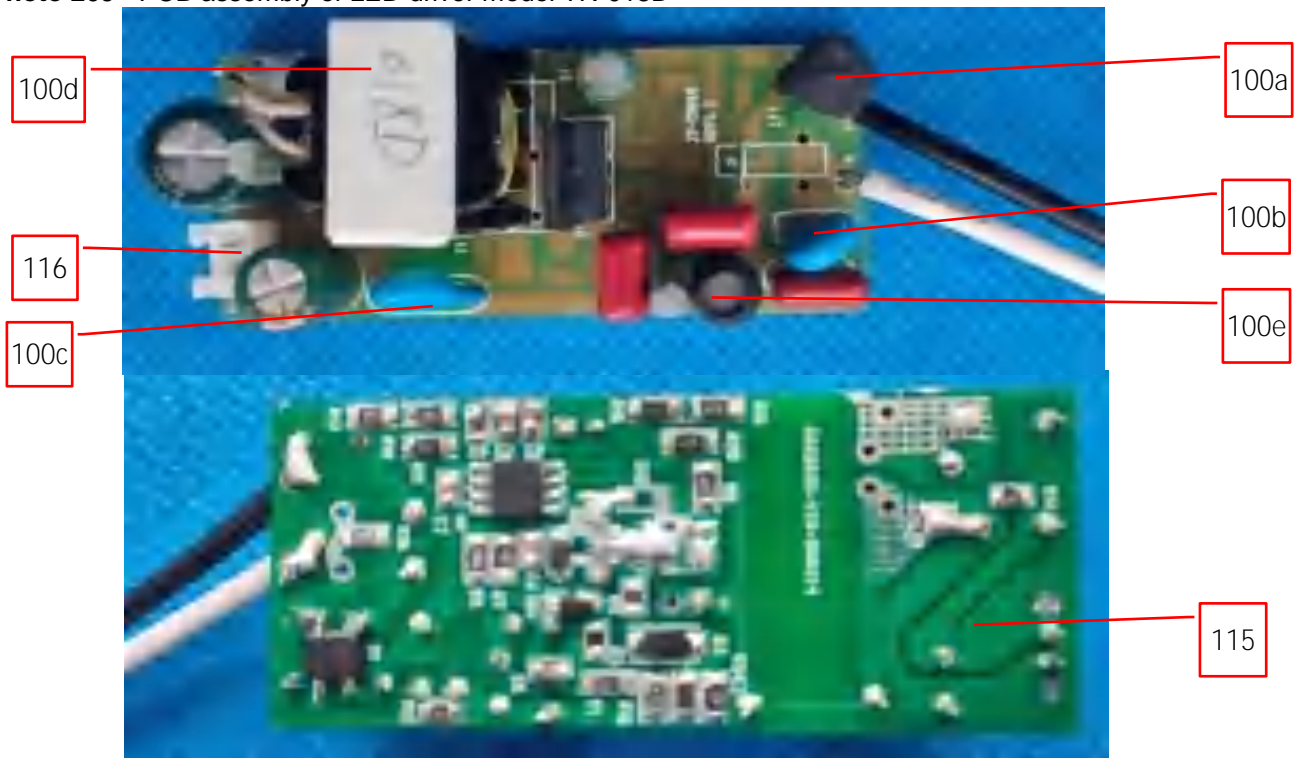


**Photo 208** - PCB assembly of LED driver model TR-031A



**3.0 Product Photographs**

**Photo 209 - PCB assembly of LED driver model TR-018D**



**Photo 210 - External view of LED Driver TR120A**

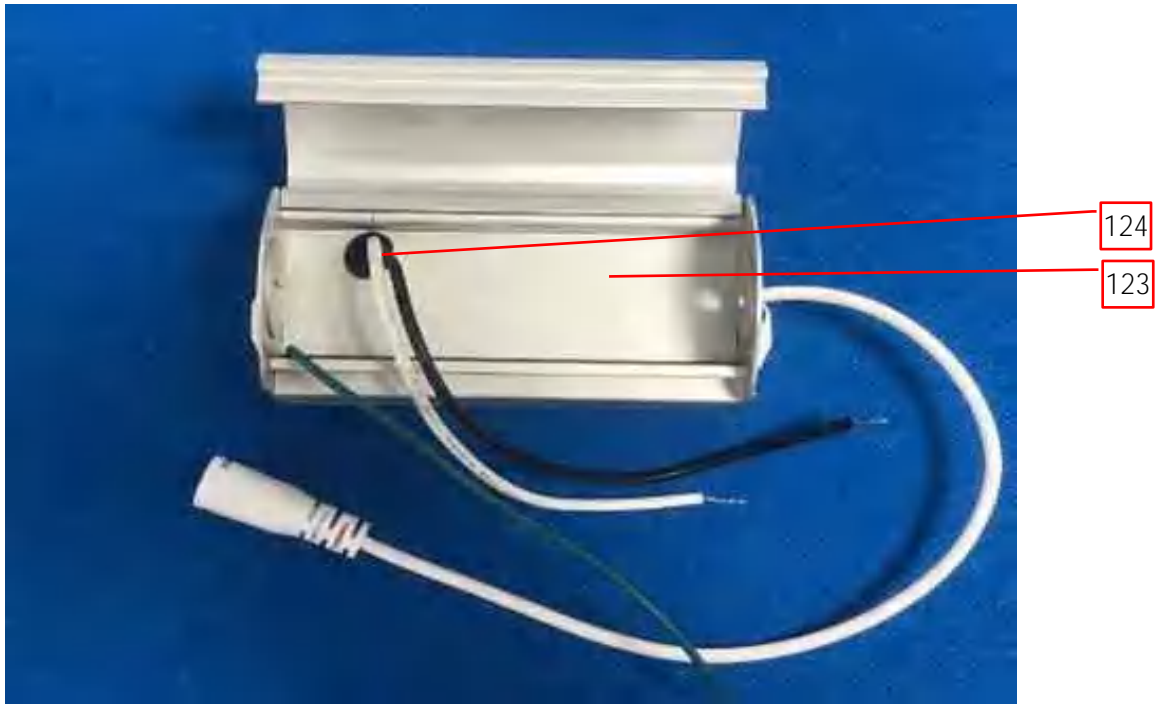


**Photo 210a - External view of LED Driver TR120A**

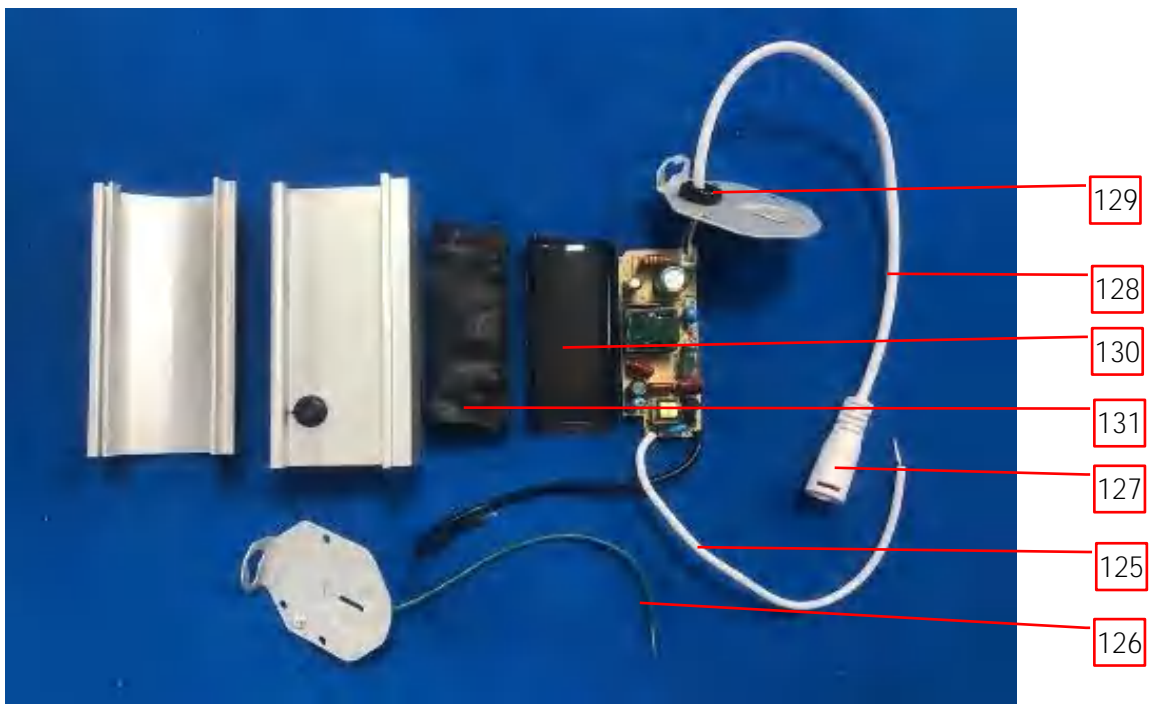


**3.0 Product Photographs**

**Photo 211** - Internal view of LED Driver model TR120A

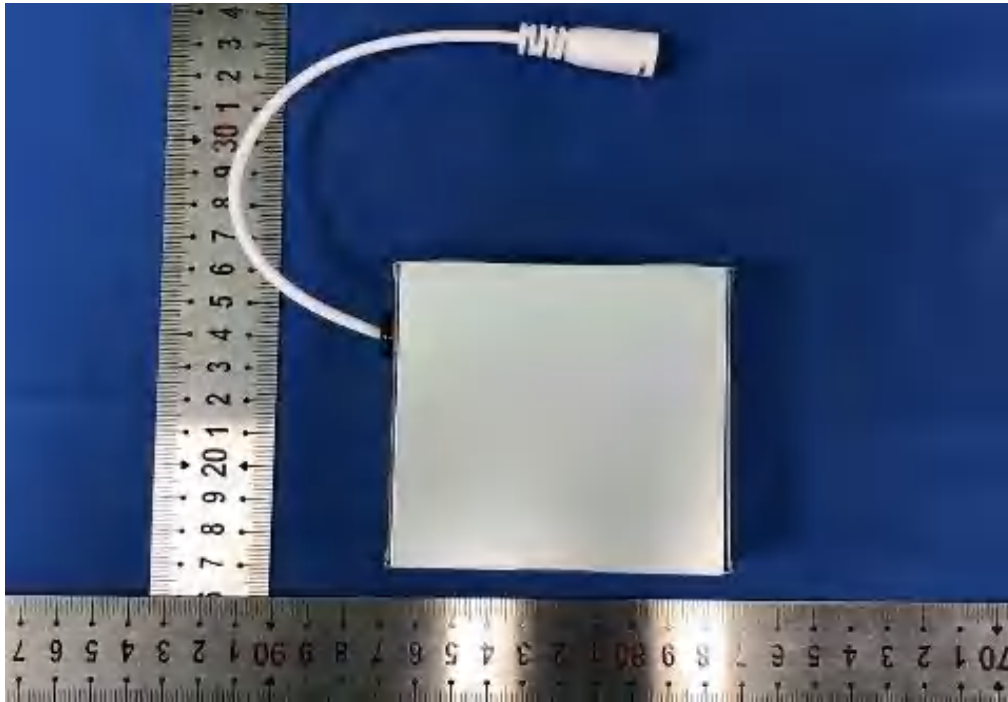


**Photo 212** - Internal view of LED Driver model TR120A

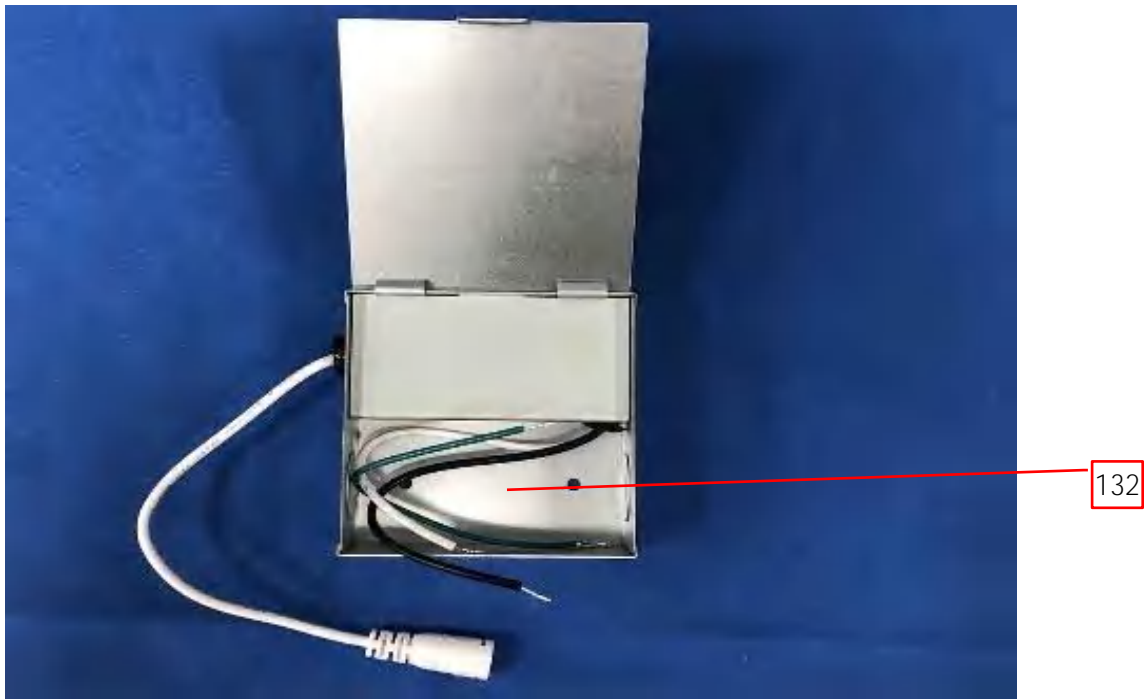


**3.0 Product Photographs**

**Photo 213** - External view of LED Driver TR120B

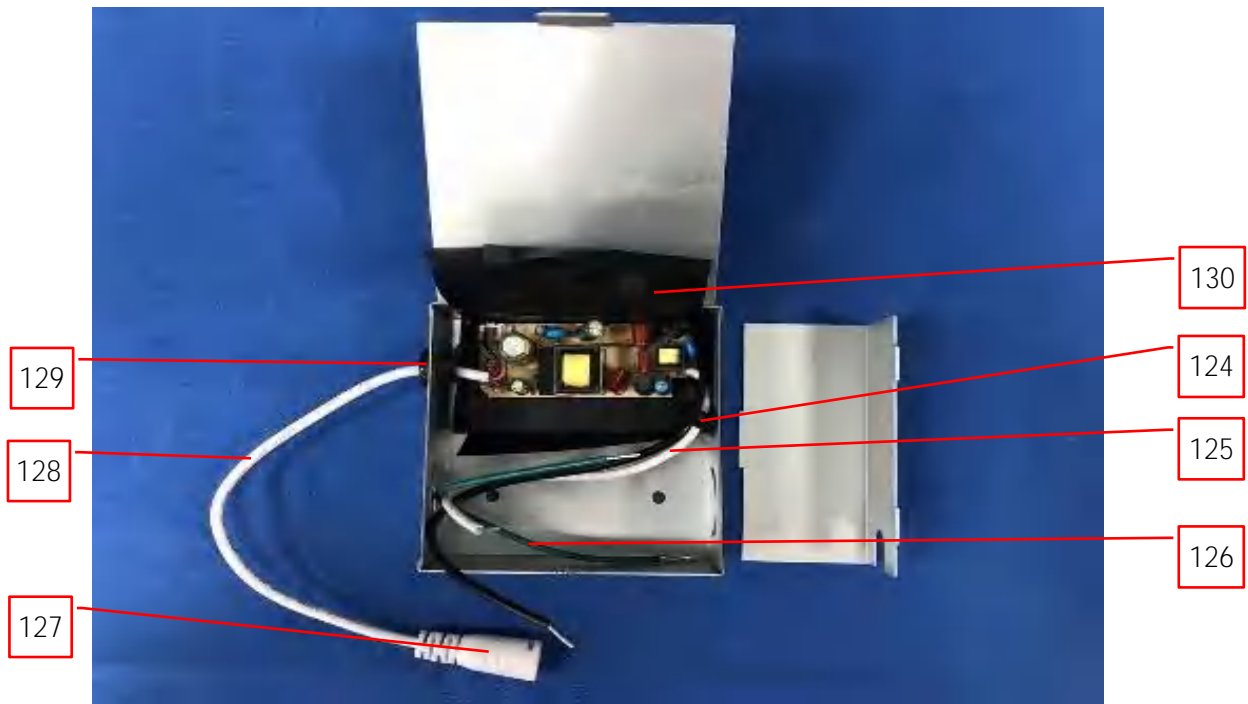


**Photo 214** - Internal view of LED Driver TR-120B

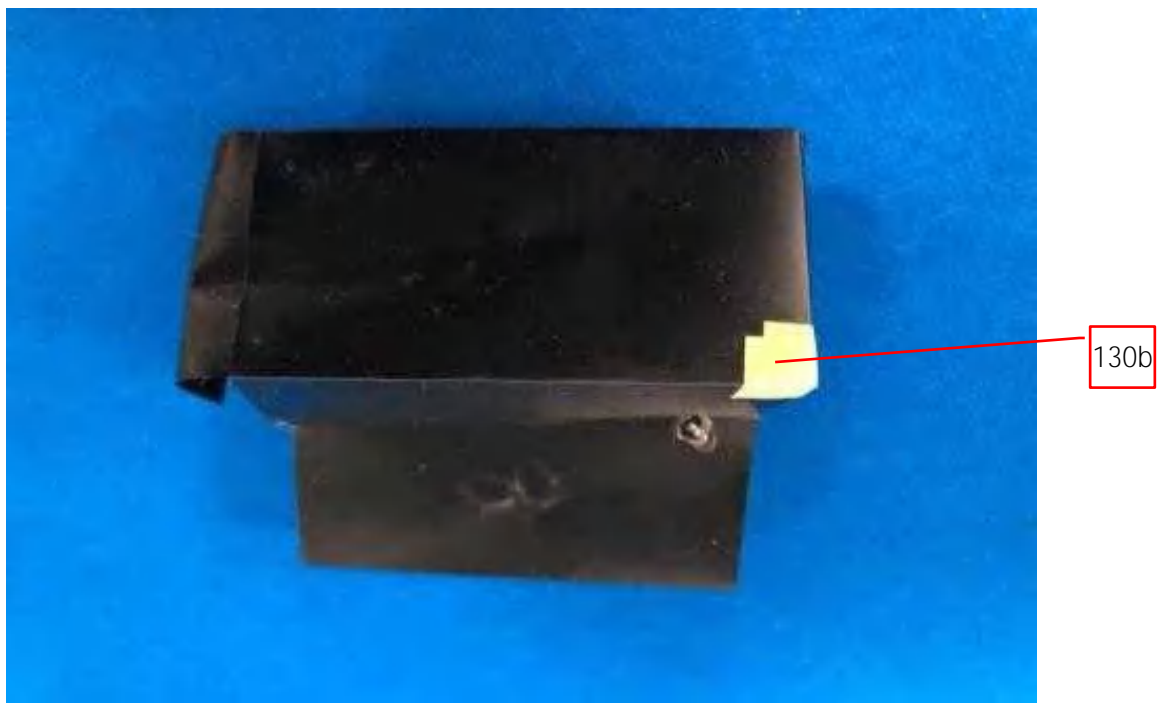


**3.0 Product Photographs**

**Photo 215** - Internal view of LED Driver TR-120B

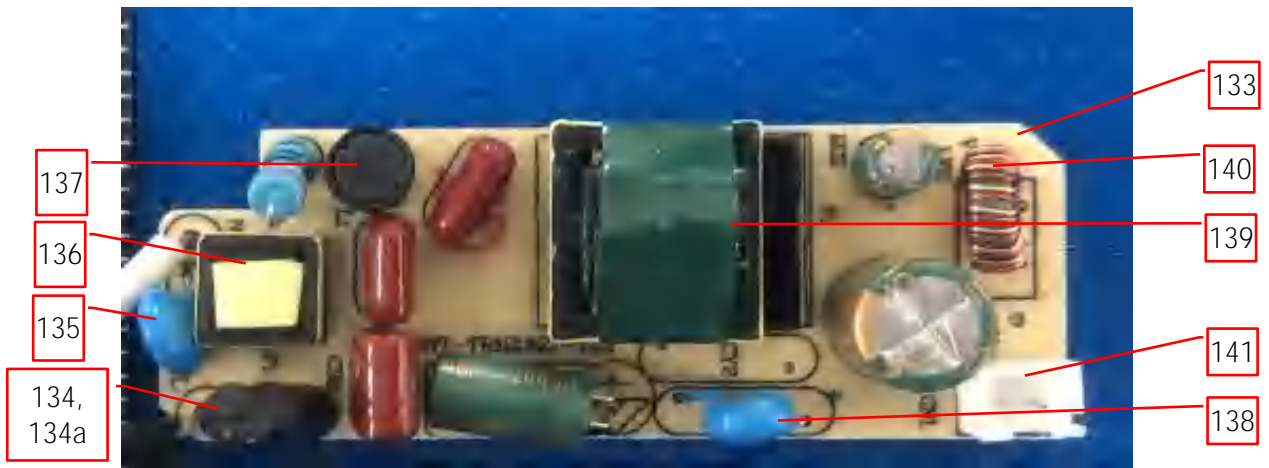


**Photo 215a** - Internal view of LED Driver TR-120B

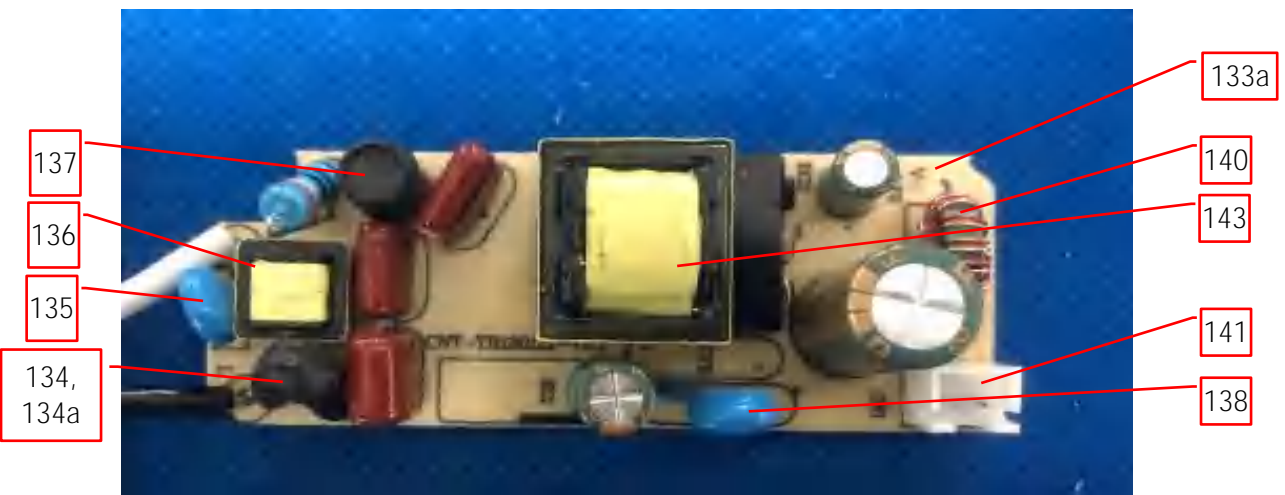


**3.0 Product Photographs**

**Photo 216** - PCB assembly of LED driver model TR-120A

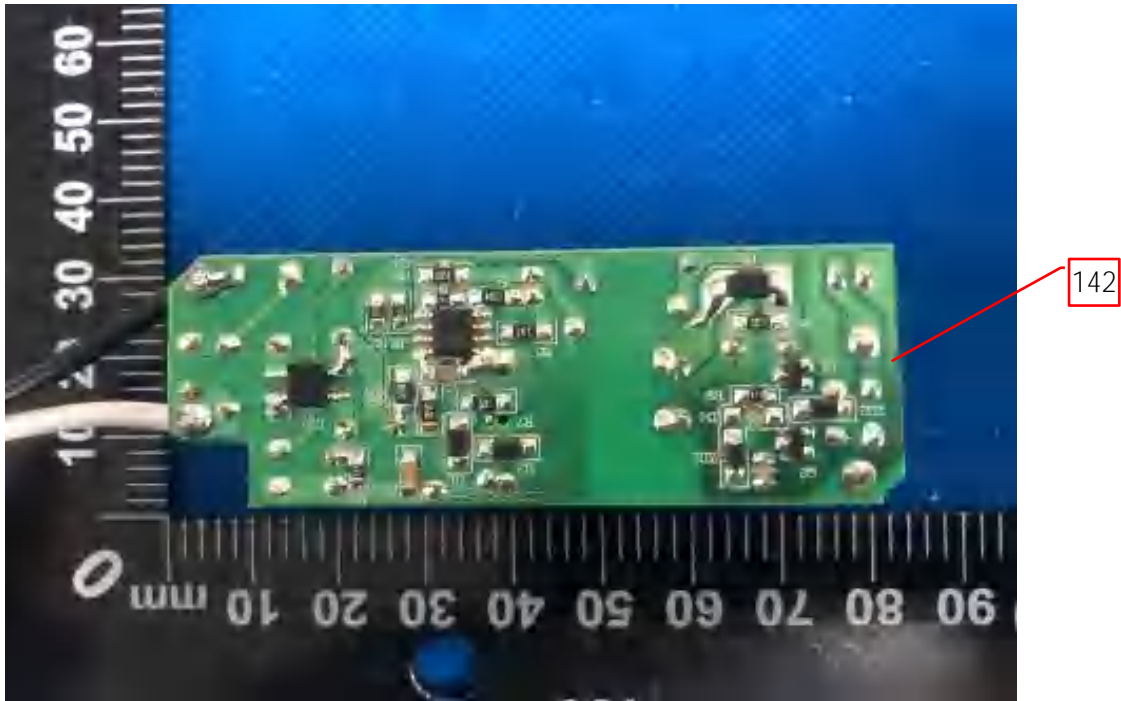


**Photo 216a** - PCB assembly of LED driver model TR-120B



### 3.0 Product Photographs

**Photo 217** - PCB assembly of LED driver model TR-120A, TR-120B



**Photo 218** - Transformer (T1) construction of driver TR-120A



### 3.0 Product Photographs

**Photo 218a** - Transformer (T1) construction of driver TR-120A



**Photo 218b** - Transformer (T1) construction of driver TR-120A



**3.0 Product Photographs**

**Photo 219** - Transformer (T1) construction of driver TR-120B



**Photo 219a** - Transformer (T1) construction of driver TR-120B



**3.0 Product Photographs**

**Photo 220** - Transformer (T1) construction of driver TR-019

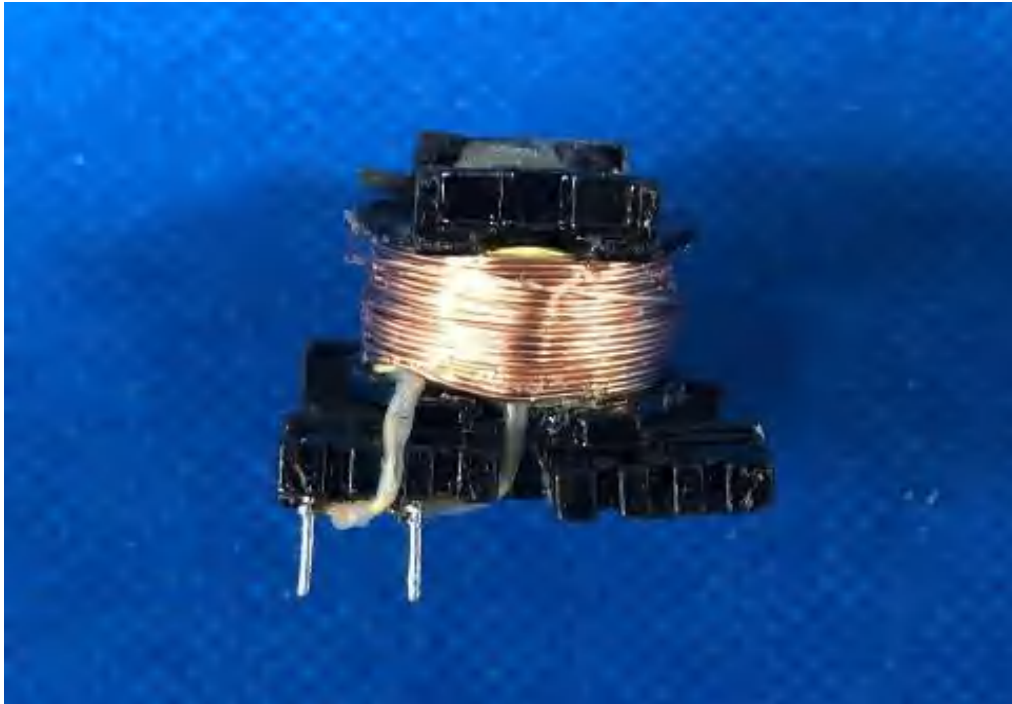


**Photo 220a** - Transformer (T1) construction of driver TR-019



### 3.0 Product Photographs

**Photo 221** - Transformer (T1) construction of driver TR-031A



**Photo 221a** - Transformer (T1) construction of driver TR-031A

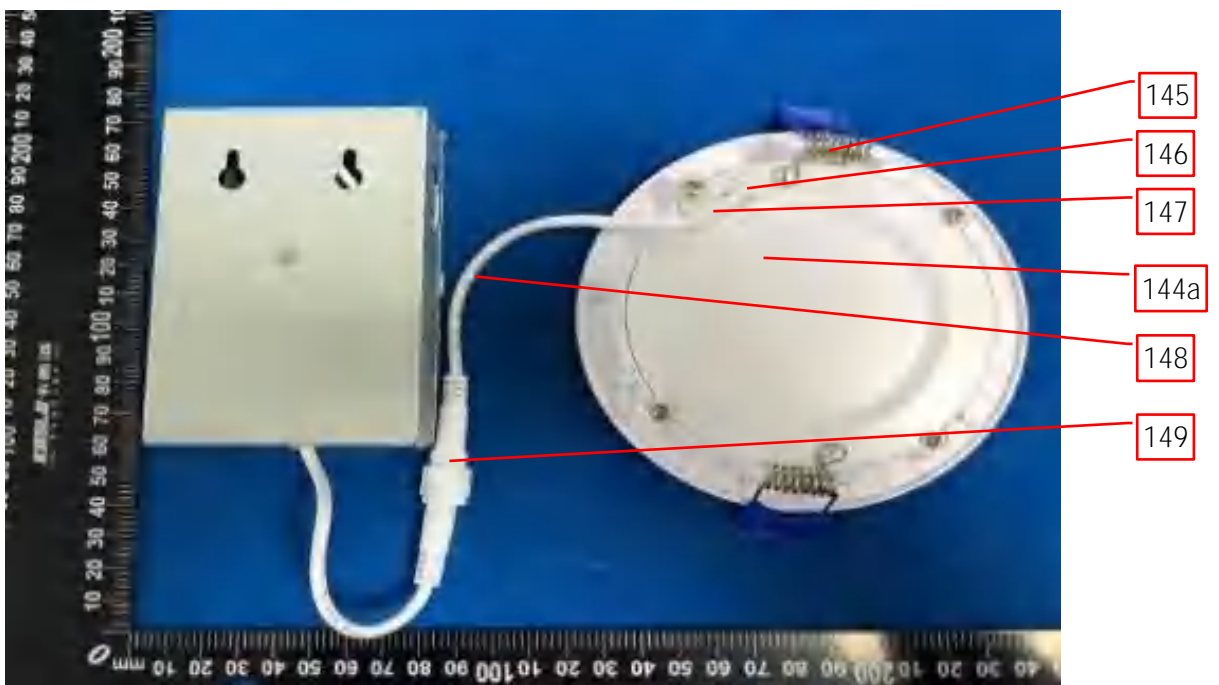


**3.0 Product Photographs**

**Photo 222** - External view of JXL-TZ04-T10W-5CCT-XX



**Photo 223** - Back view of JXL-TZ04-T10W-5CCT-XX



**3.0 Product Photographs**

**Photo 224** - Internal view of JXL-TZ04-T10W-5CCT-XX

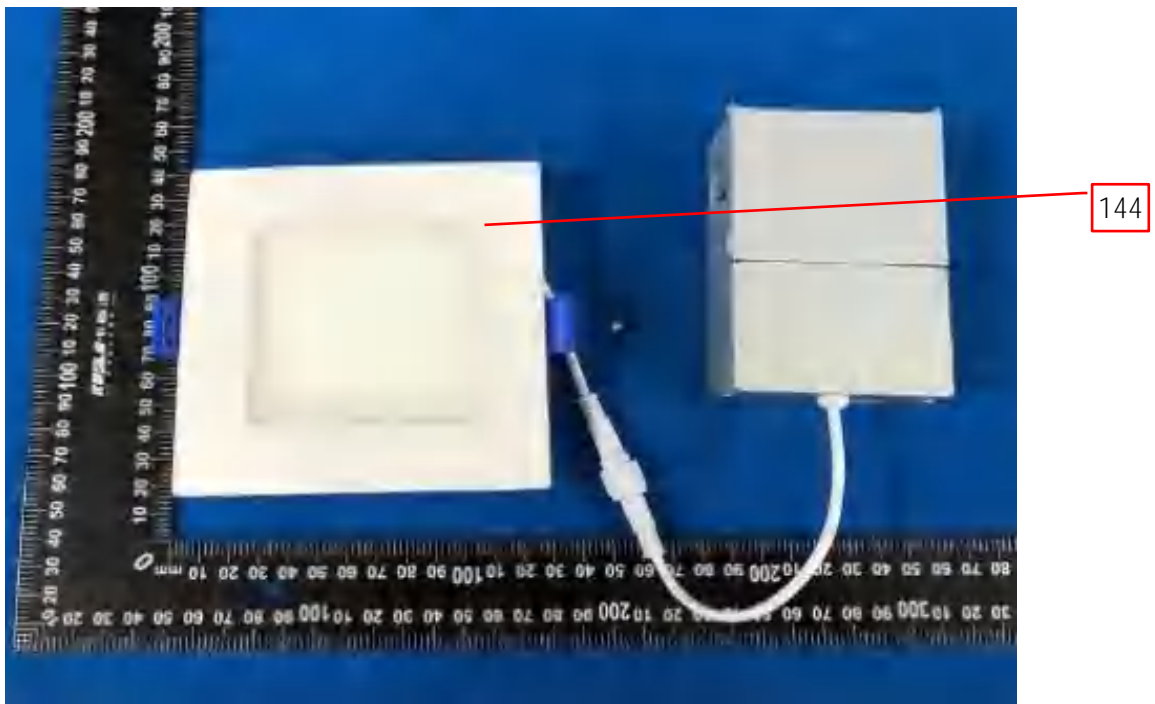


**Photo 225** - Internal view of JXL-TZ04-T10W-5CCT-XX

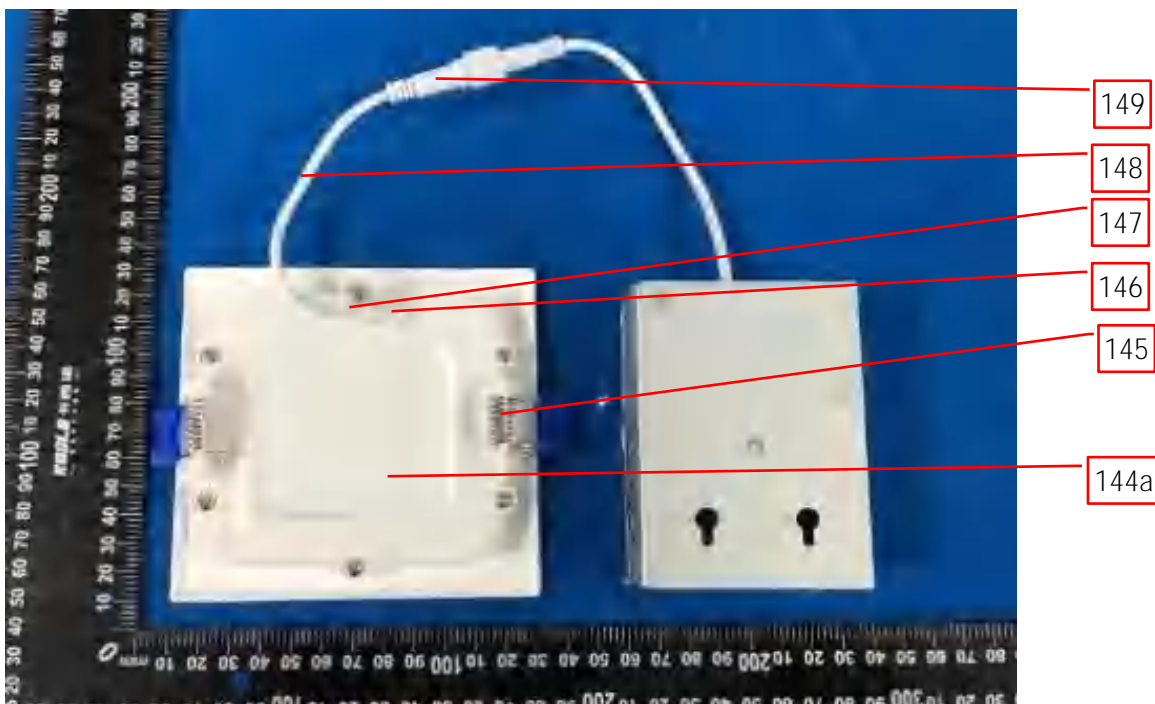


**3.0 Product Photographs**

**Photo 226** - External view of JXL-CM04-T10W-5CCT

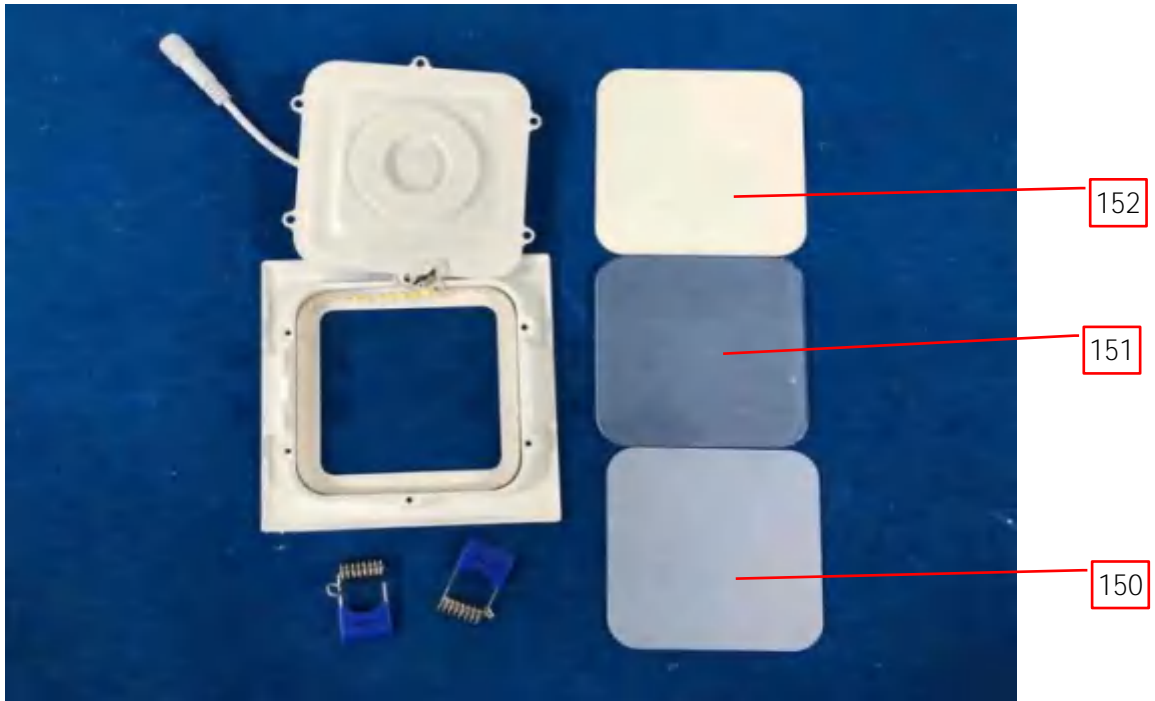


**Photo 227** - Back view of JXL-CM04-T10W-5CCT



**3.0 Product Photographs**

**Photo 228** - Internal view of JXL-CM04-T10W-5CCT



**Photo 229** - Internal view of JXL-CM04-T10W-5CCT

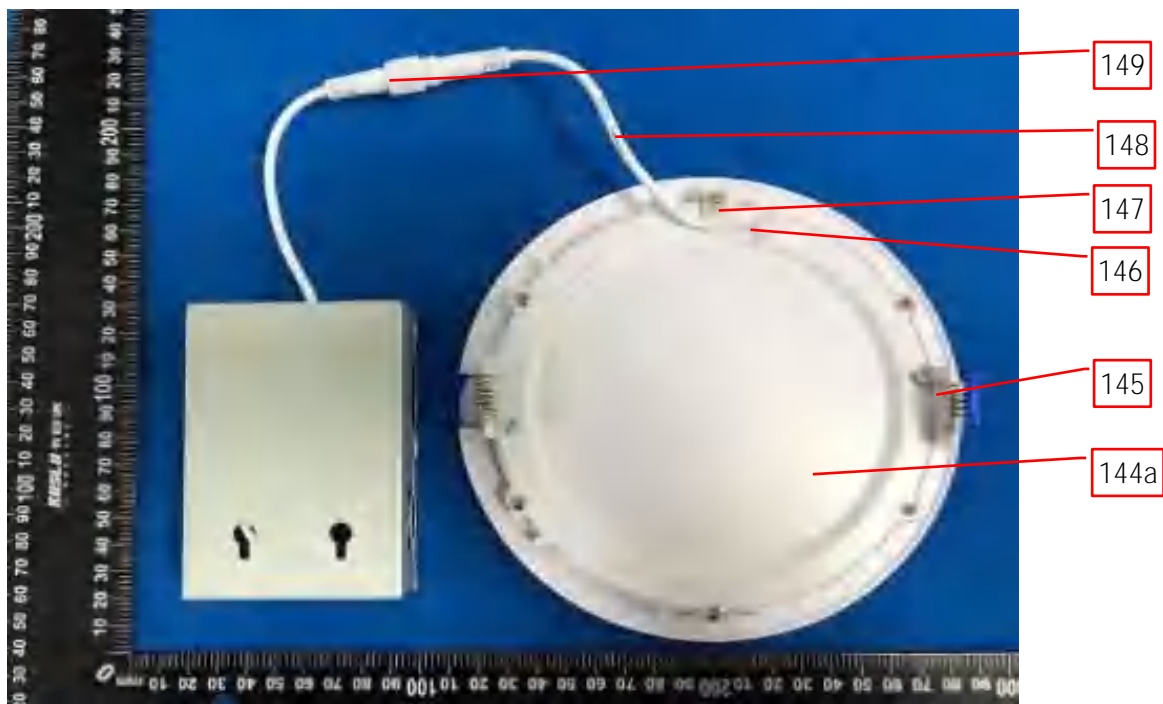


**3.0 Product Photographs**

**Photo 230** - External view of JXL-TZ06-T12W-5CCT-XX



**Photo 231** - Back view of JXL-TZ06-T12W-5CCT-XX



**3.0 Product Photographs**

**Photo 232** - Internal view of JXL-TZ06-T12W-5CCT-XX

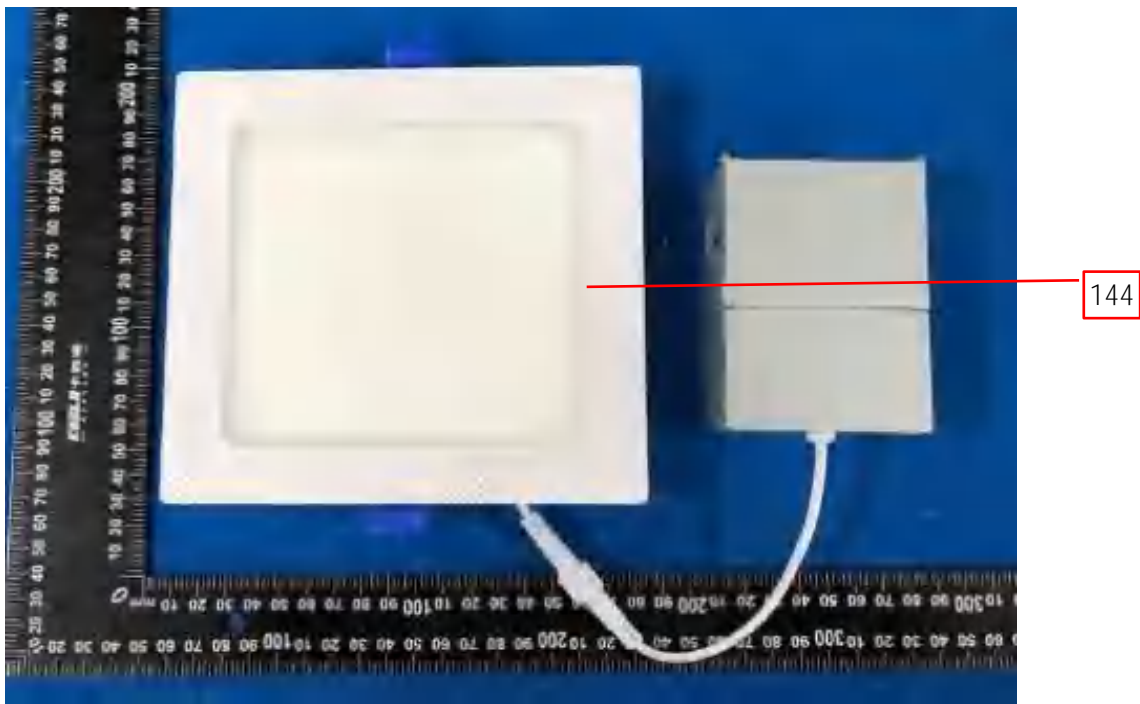


**Photo 233** - Internal view of JXL-TZ06-T12W-5CCT-XX

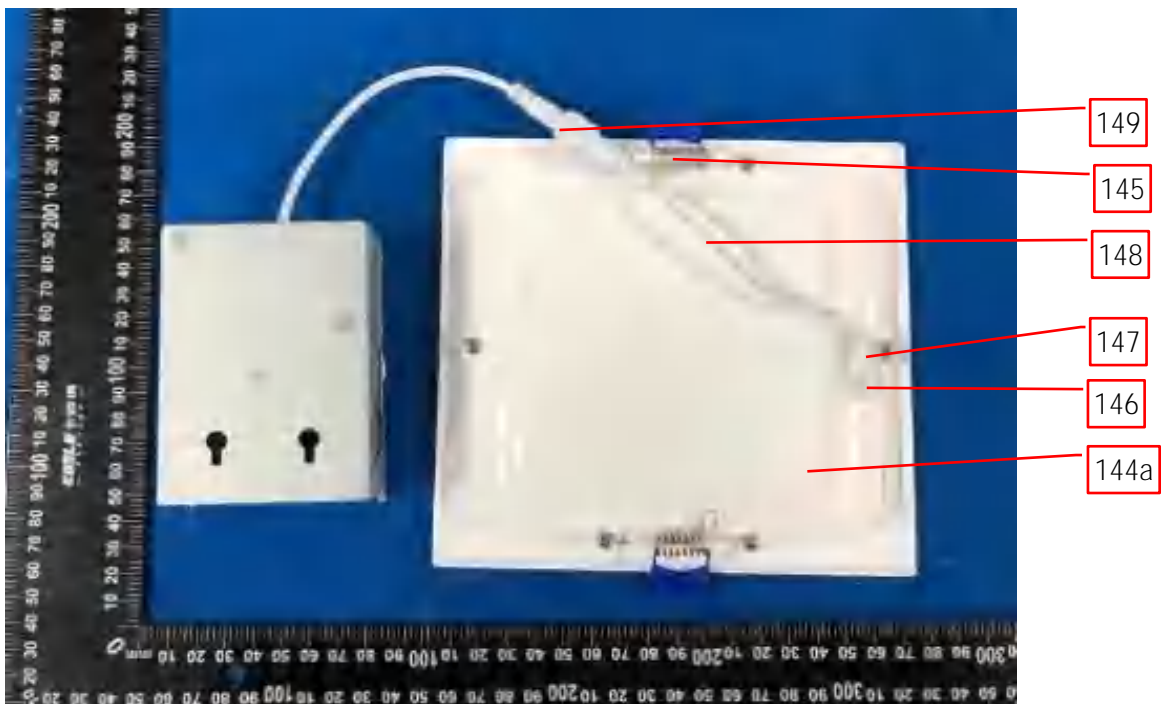


**3.0 Product Photographs**

**Photo 234** - External view of JXL-CM06-T12W-5CCT

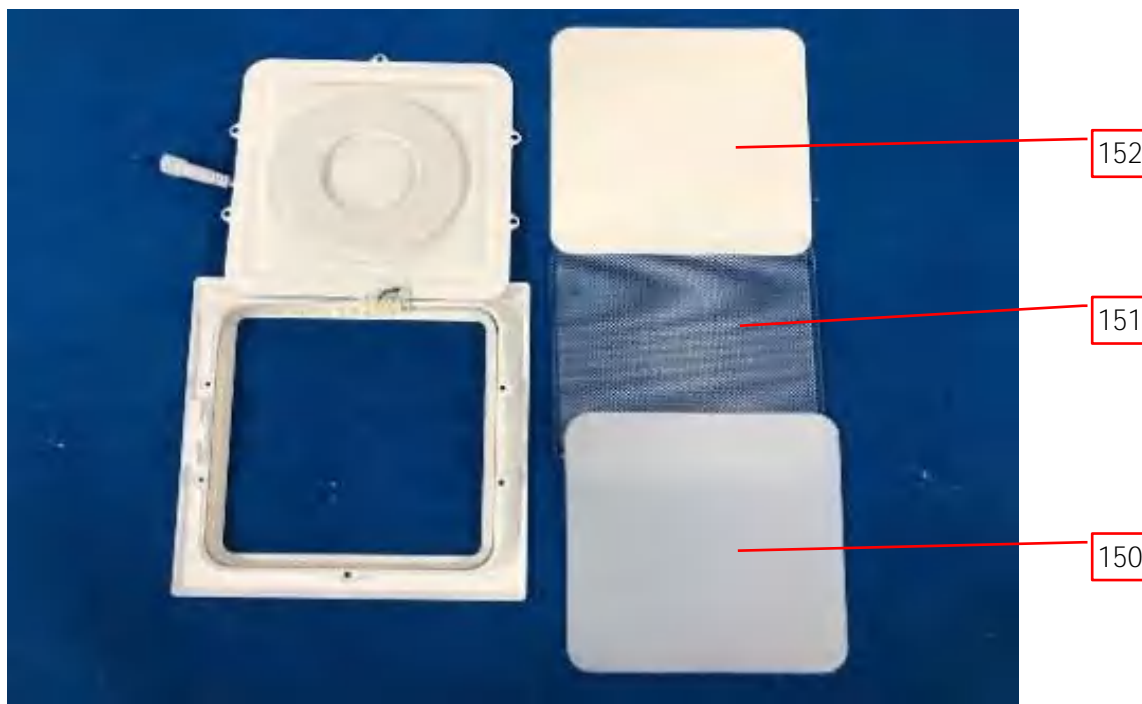


**Photo 235** - Back view of JXL-CM06-T12W-5CCT



**3.0 Product Photographs**

**Photo 236** - Internal view of JXL-CM06-T12W-5CCT



**Photo 237** - Internal view of JXL-CM06-T12W-5CCT

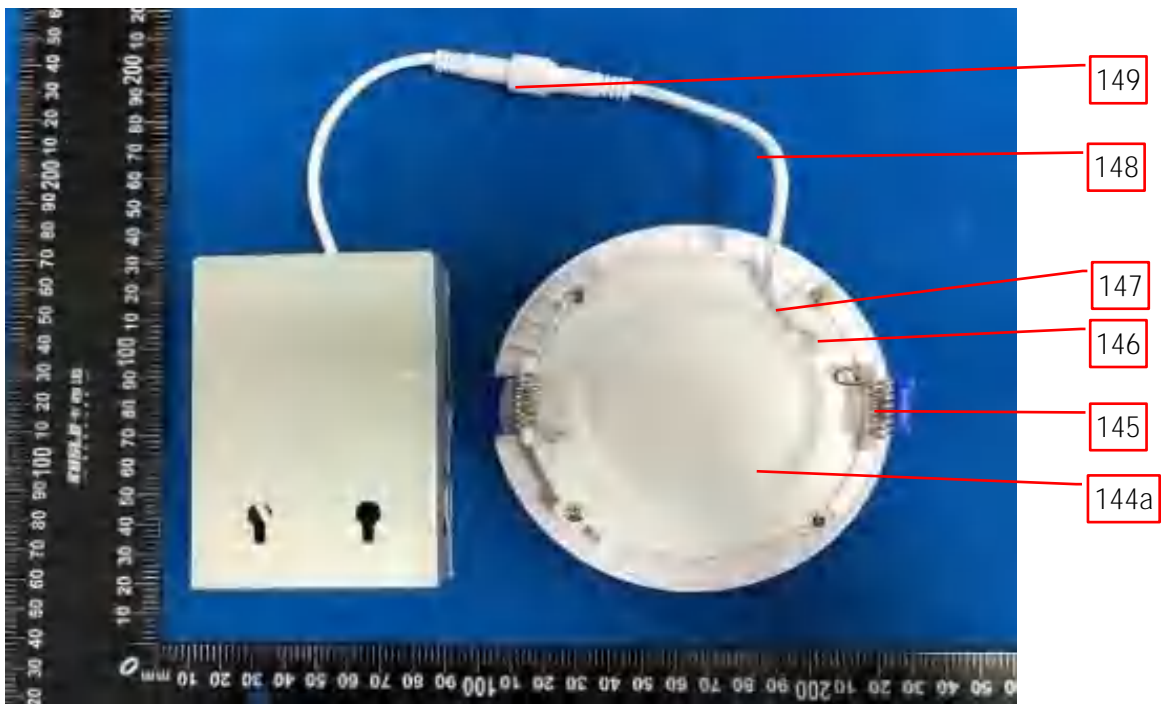


**3.0 Product Photographs**

**Photo 238** - External view of JXL-CA04-T10W-5CCT-XX



**Photo 239** - Back view of JXL-CA04-T10W-5CCT-XX



**3.0 Product Photographs**

**Photo 240** - Internal view of JXL-CA04-T10W-5CCT-XX

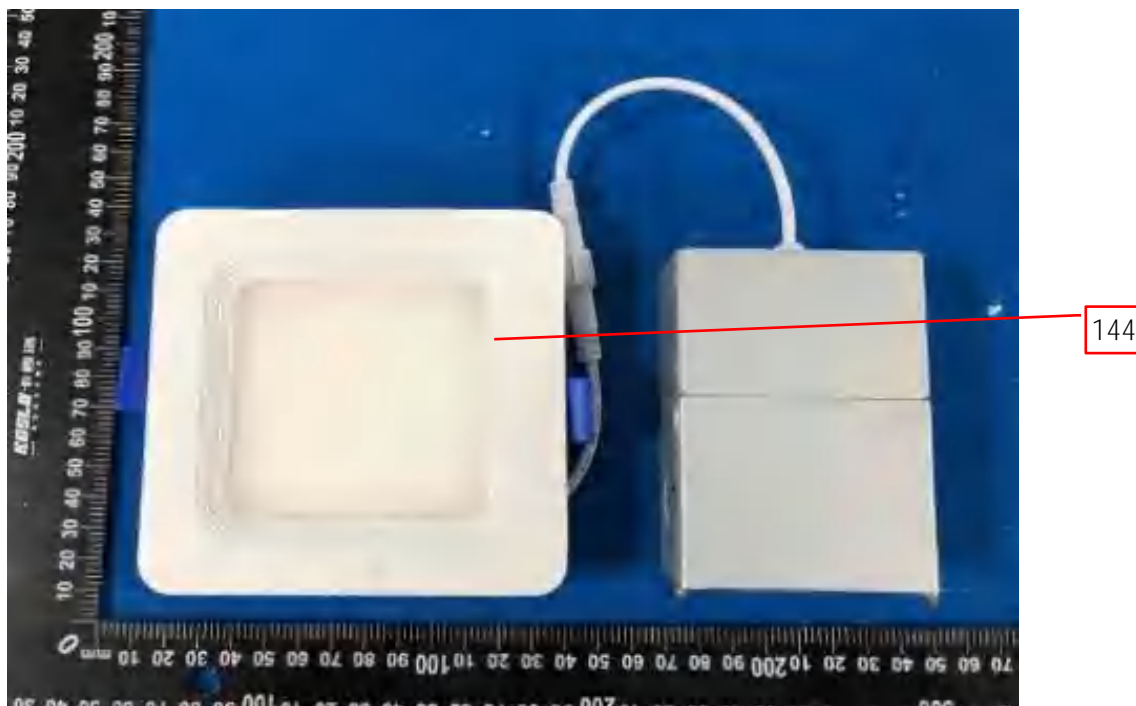


**Photo 241** - Internal view of JXL-CA04-T10W-5CCT-XX

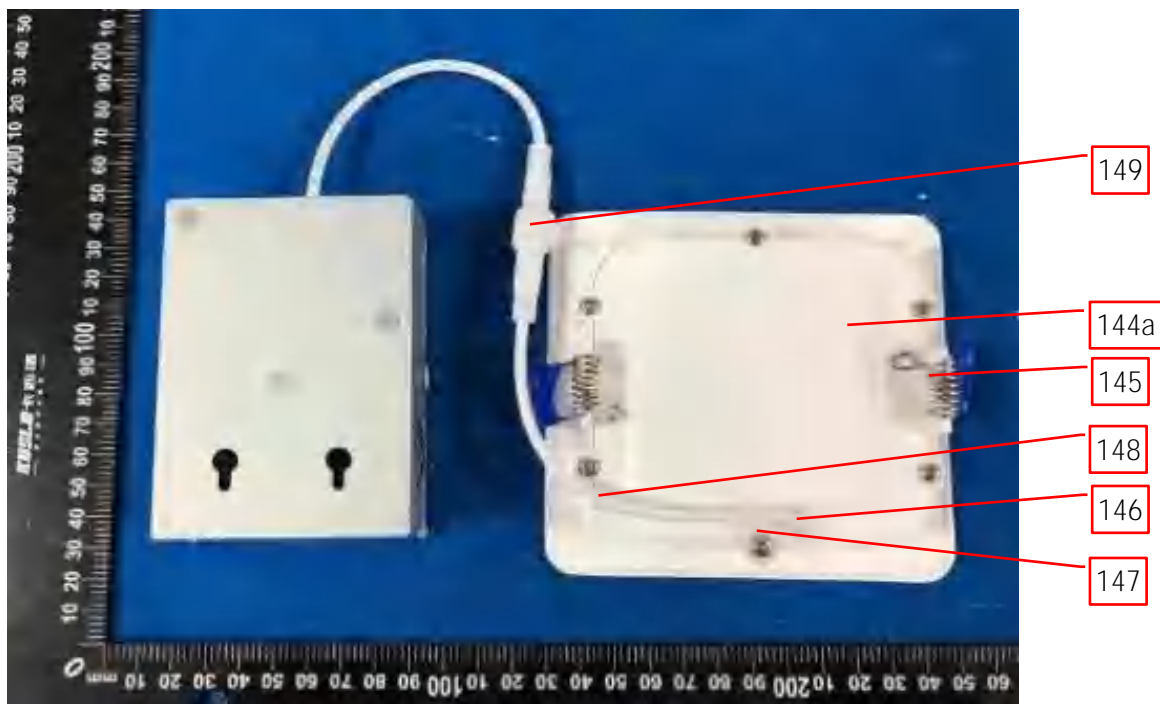


**3.0 Product Photographs**

**Photo 242** - External view of JXL-CF04-T10W-5CCT

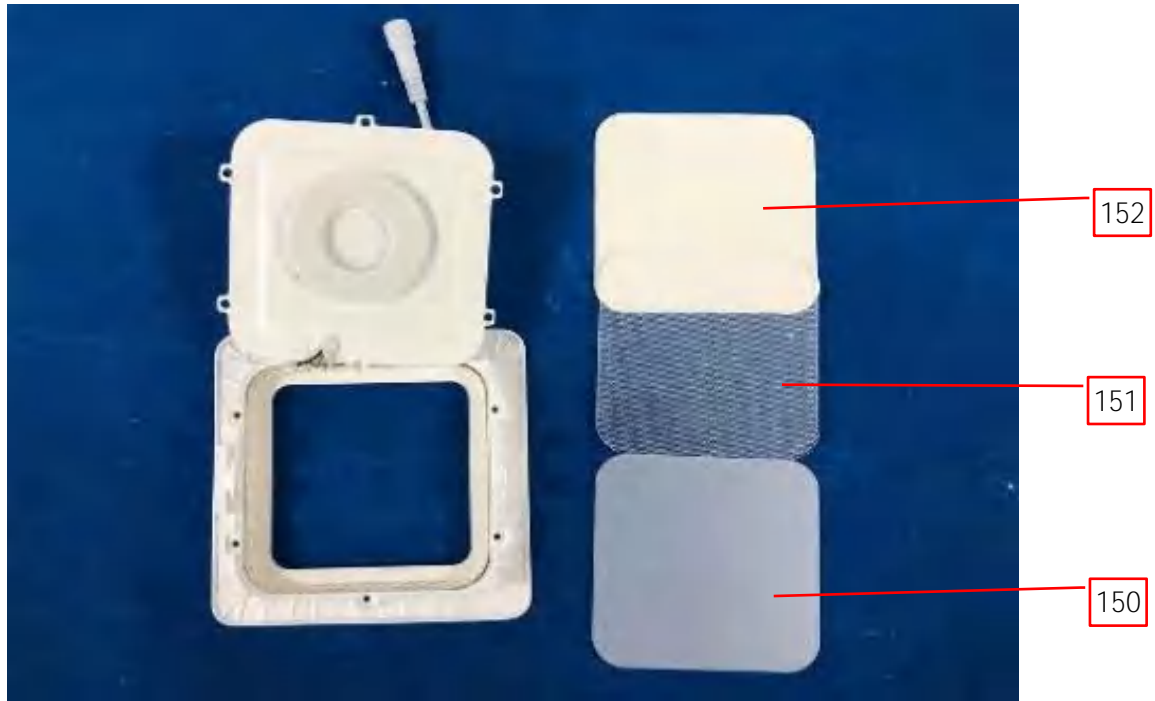


**Photo 243** - Back view of JXL-CF04-T10W-5CCT



**3.0 Product Photographs**

**Photo 244** - Internal view of JXL-CF04-T10W-5CCT



**Photo 245** - Internal view of JXL-CF04-T10W-5CCT



**3.0 Product Photographs**

**Photo 246** - External view of JXL-CA06-T12W-5CCT-XX



**Photo 247** - Back view of JXL-CA06-T12W-5CCT-XX



**3.0 Product Photographs**

**Photo 248** - Internal view of JXL-CA06-T12W-5CCT-XX



**Photo 249** - Internal view of JXL-CA06-T12W-5CCT-XX

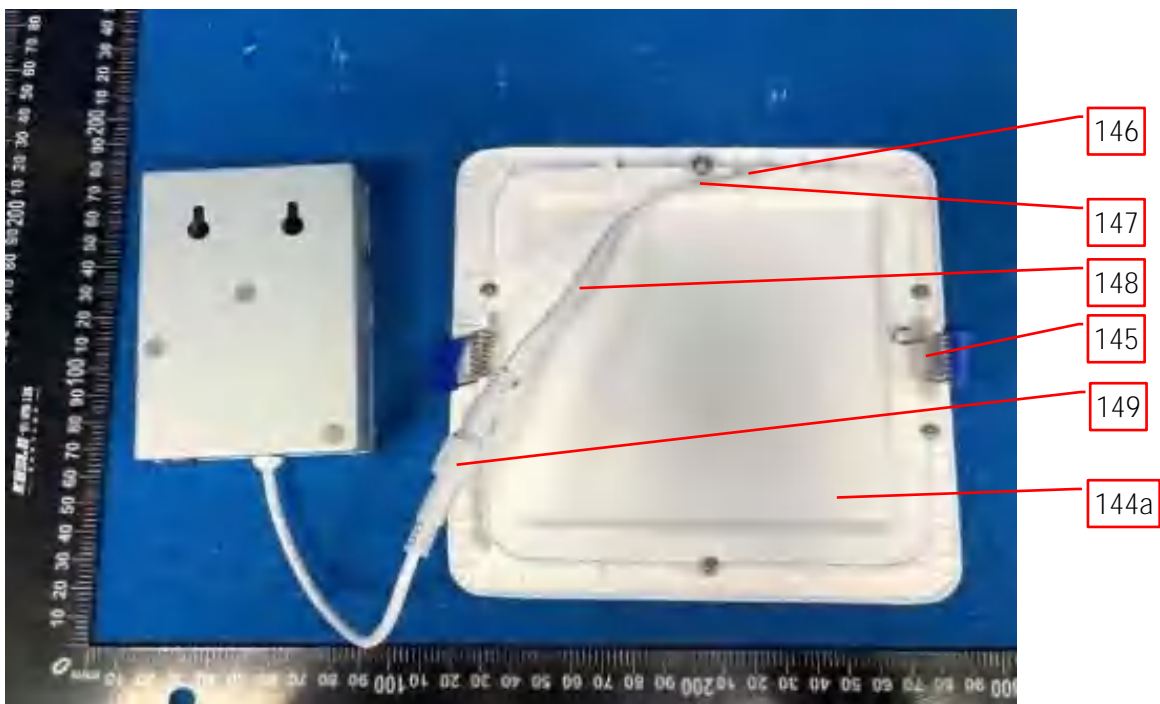


**3.0 Product Photographs**

**Photo 250** - External view of JXL-CF06-T12W-5CCT

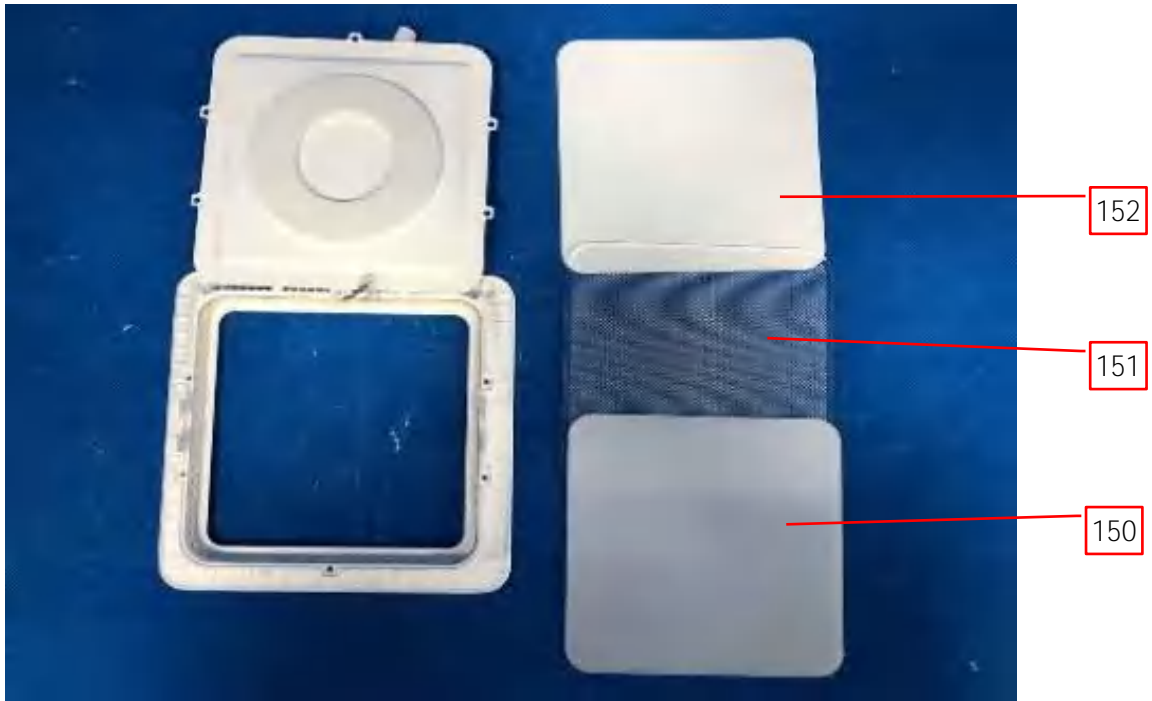


**Photo 251** - Back view of JXL-CF06-T12W-5CCT

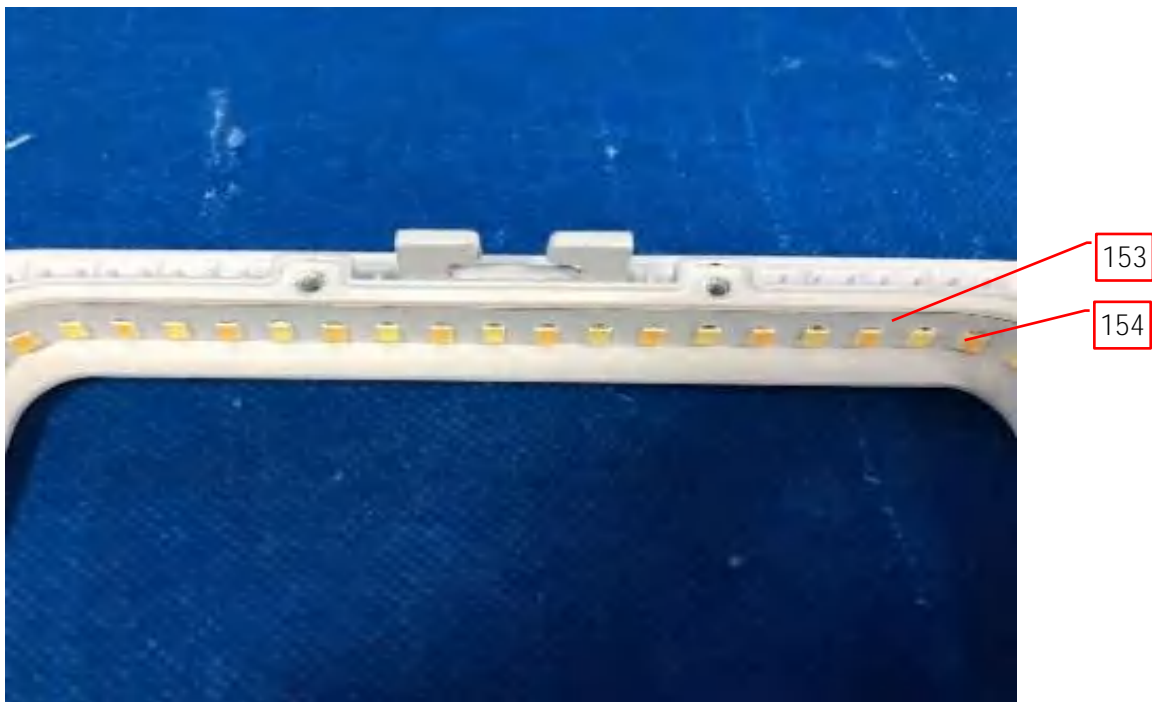


**3.0 Product Photographs**

**Photo 252** - Internal view of JXL-CF06-T12W-5CCT



**Photo 253** - Internal view of JXL-CF06-T12W-5CCT

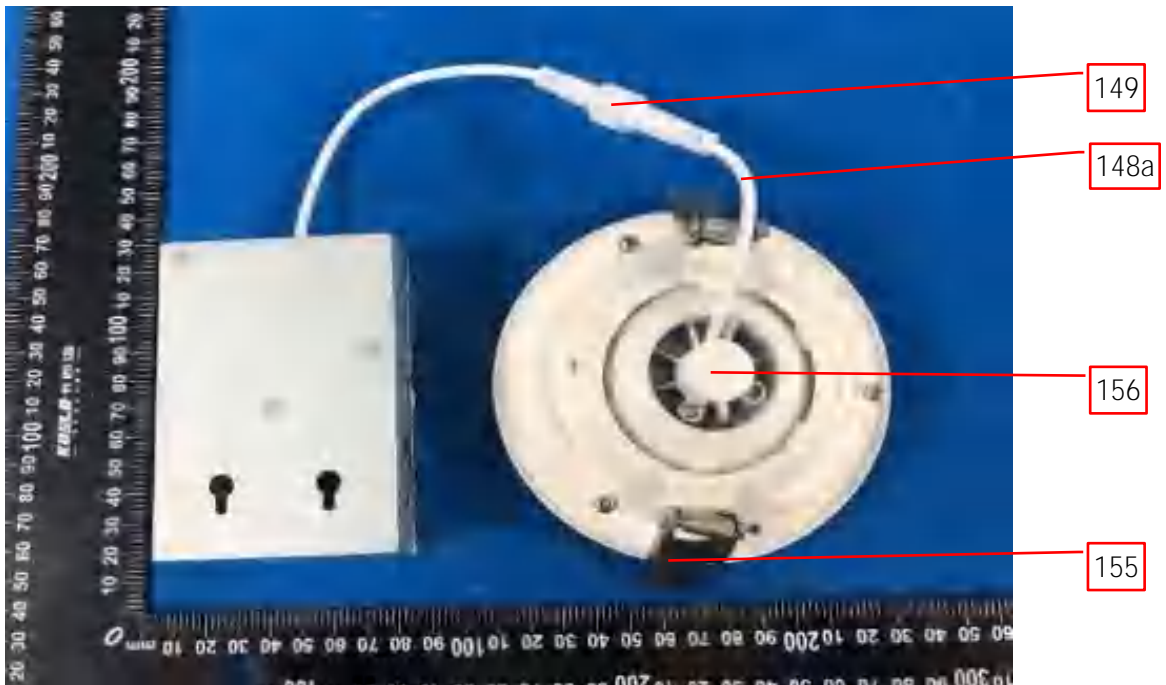


**3.0 Product Photographs**

**Photo 254** - External view of JXL-COB04-G12W-5CCT

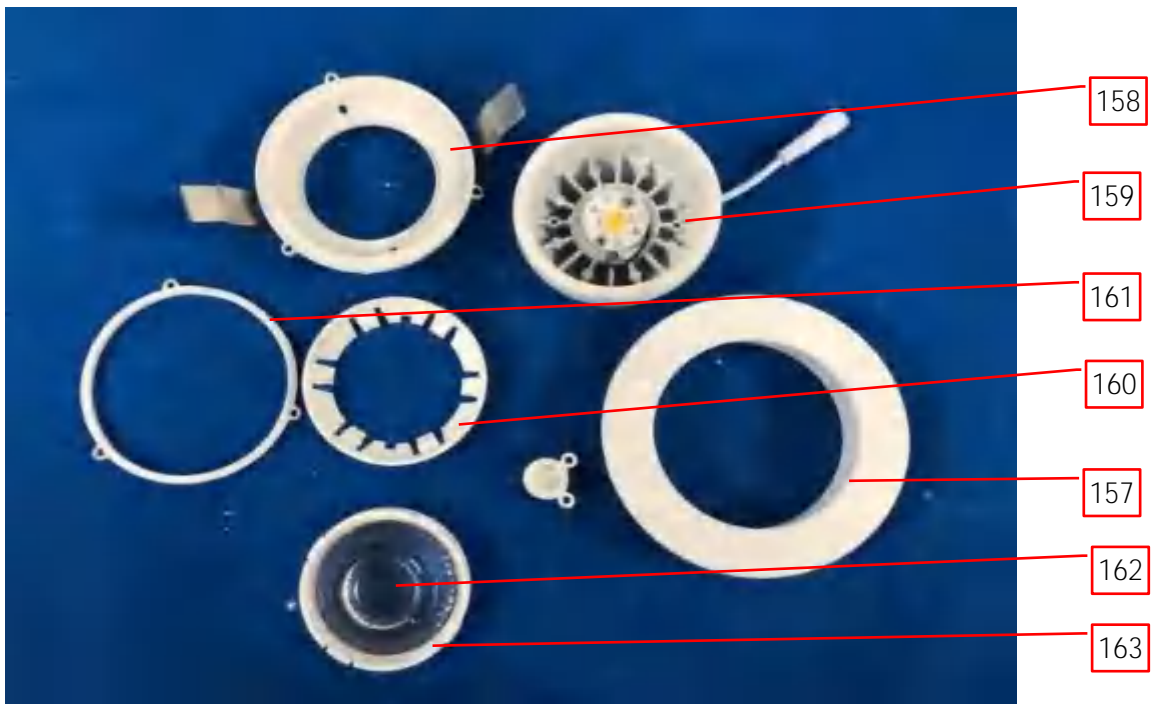


**Photo 255** - Back view of JXL-COB04-G12W-5CCT

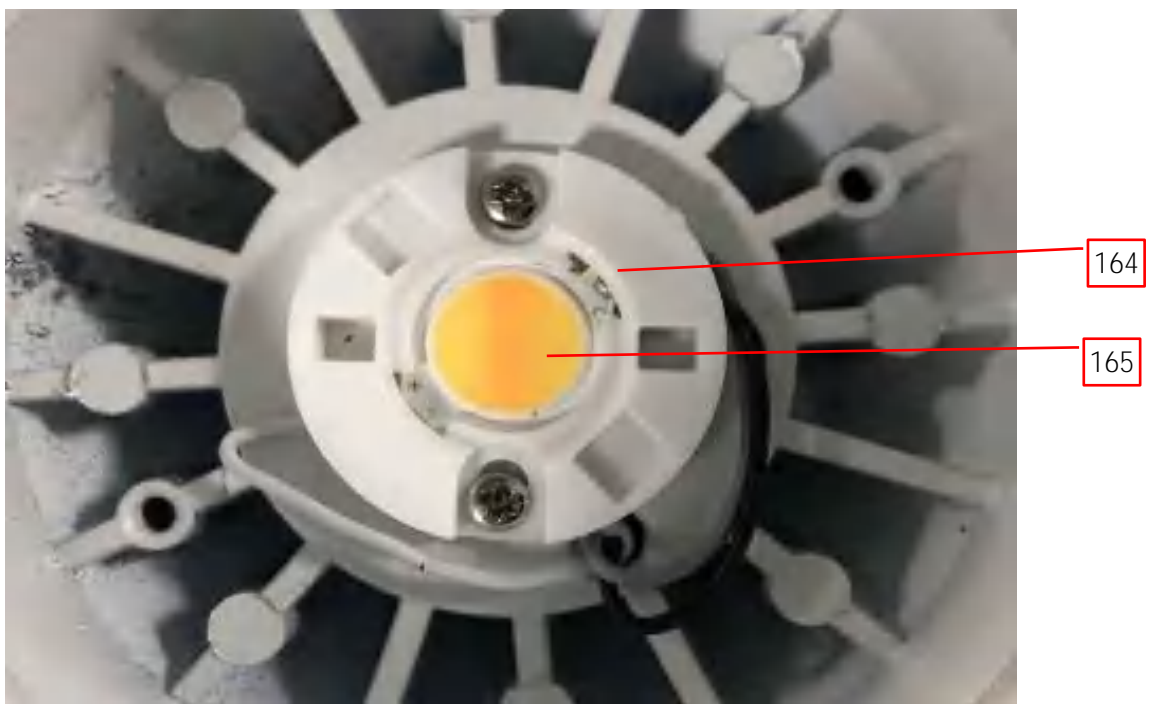


**3.0 Product Photographs**

**Photo 256** - Internal view of JXL-COB04-G12W-5CCT



**Photo 257** - Internal view of JXL-COB04-G12W-5CCT

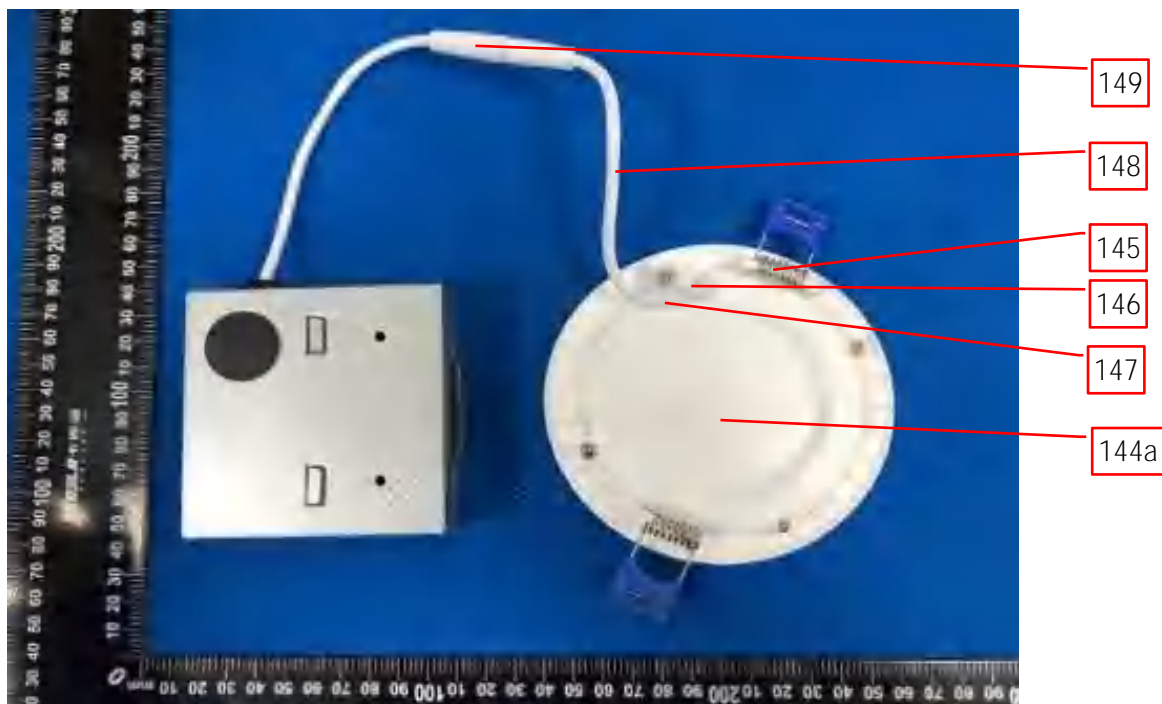


**3.0 Product Photographs**

**Photo 258** - External view of JXL-TZ04-T10W-RGBCW

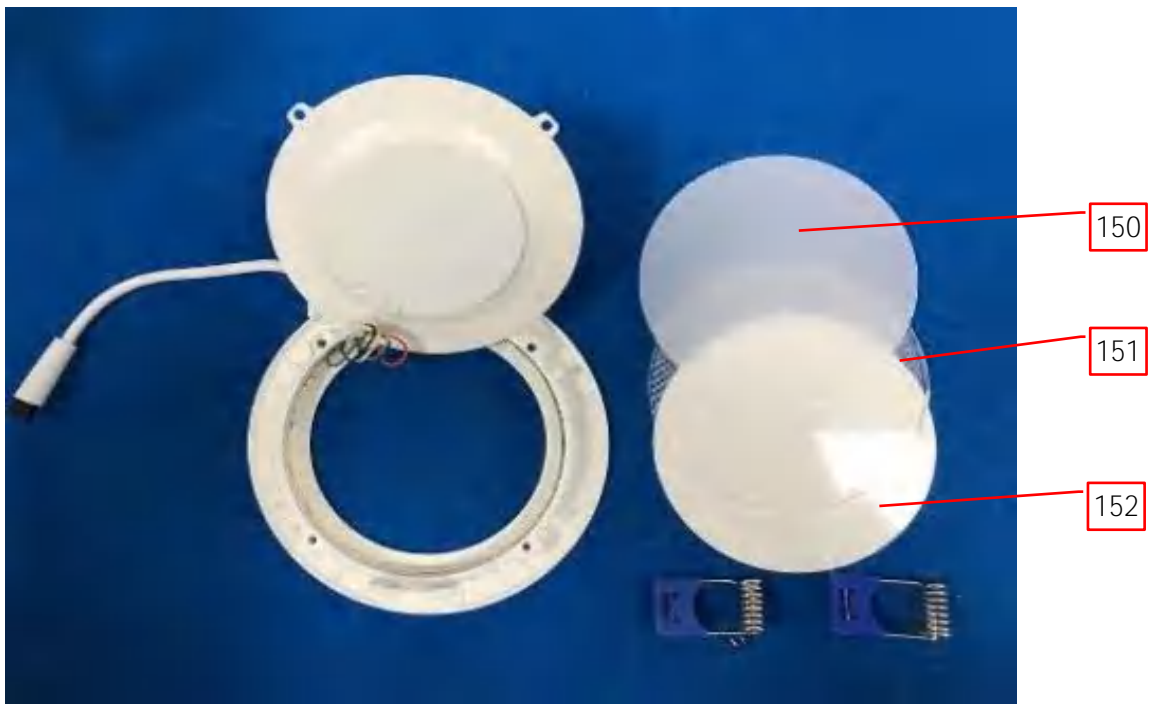


**Photo 259** - Back view of JXL-TZ04-T10W-RGBCW



**3.0 Product Photographs**

**Photo 260** - Internal view of JXL-TZ04-T10W-RGBCW



**Photo 261** - Internal view of JXL-TZ04-T10W-RGBCW

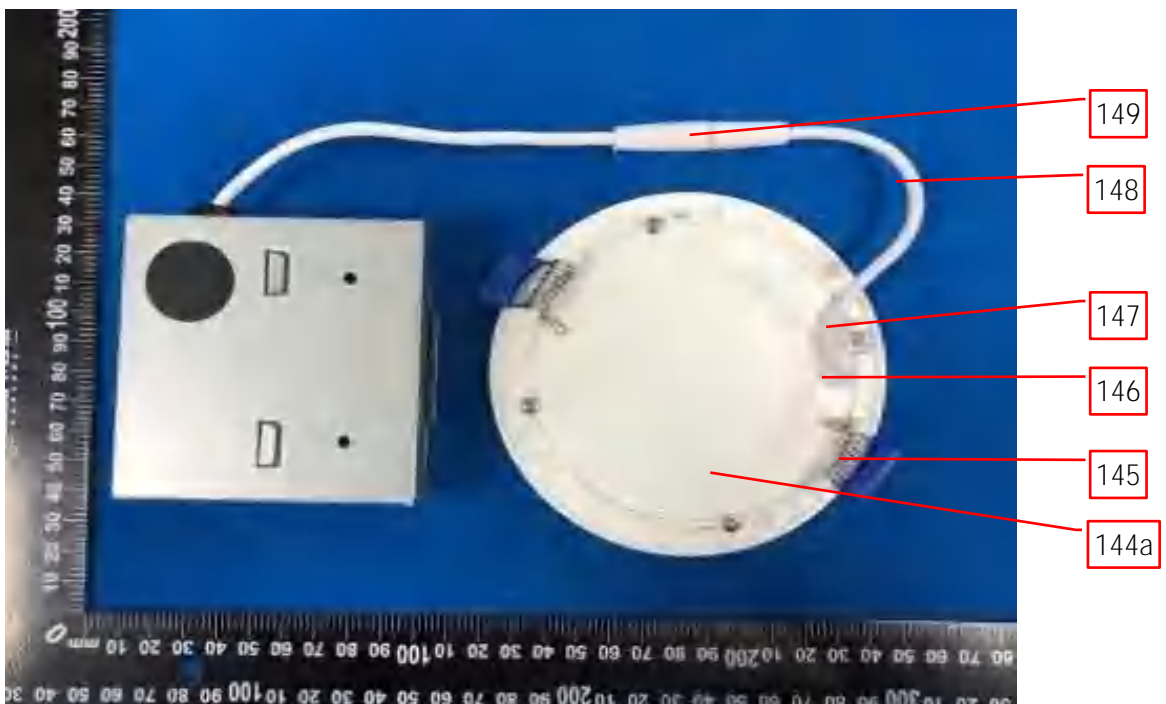


**3.0 Product Photographs**

**Photo 262** - External view of JXL-CA04-T10W-RGBCW



**Photo 263** - Back view of JXL-CA04-T10W-RGBCW

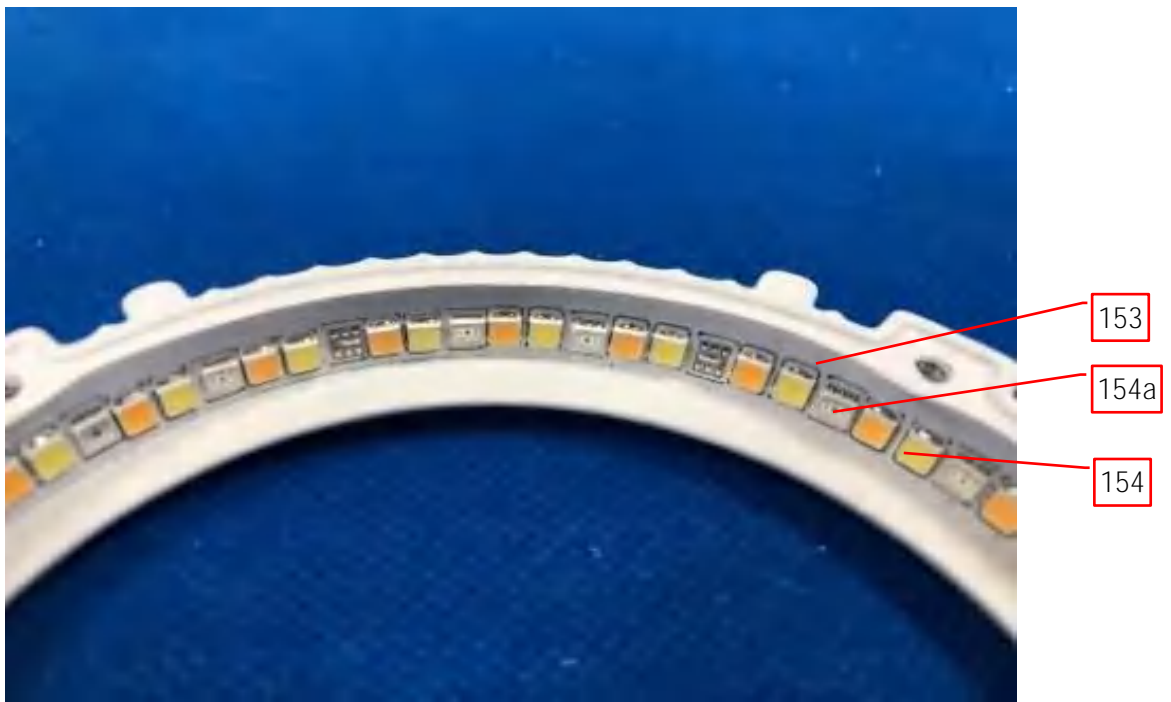


**3.0 Product Photographs**

**Photo 264** - Internal view of JXL-CA04-T10W-RGBCW



**Photo 265** - Internal view of JXL-CA04-T10W-RGBCW

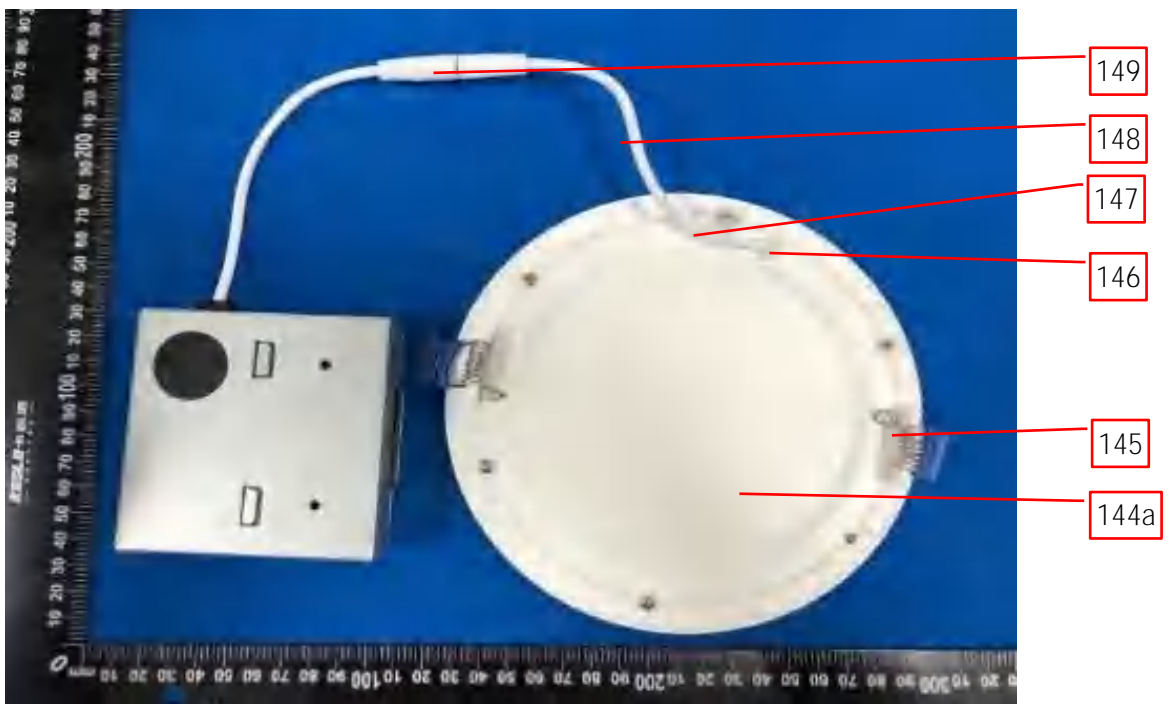


**3.0 Product Photographs**

**Photo 266** - External view of JXL-TZ06-T12W-RGBCW



**Photo 267** - Back view of JXL-TZ06-T12W-RGBCW

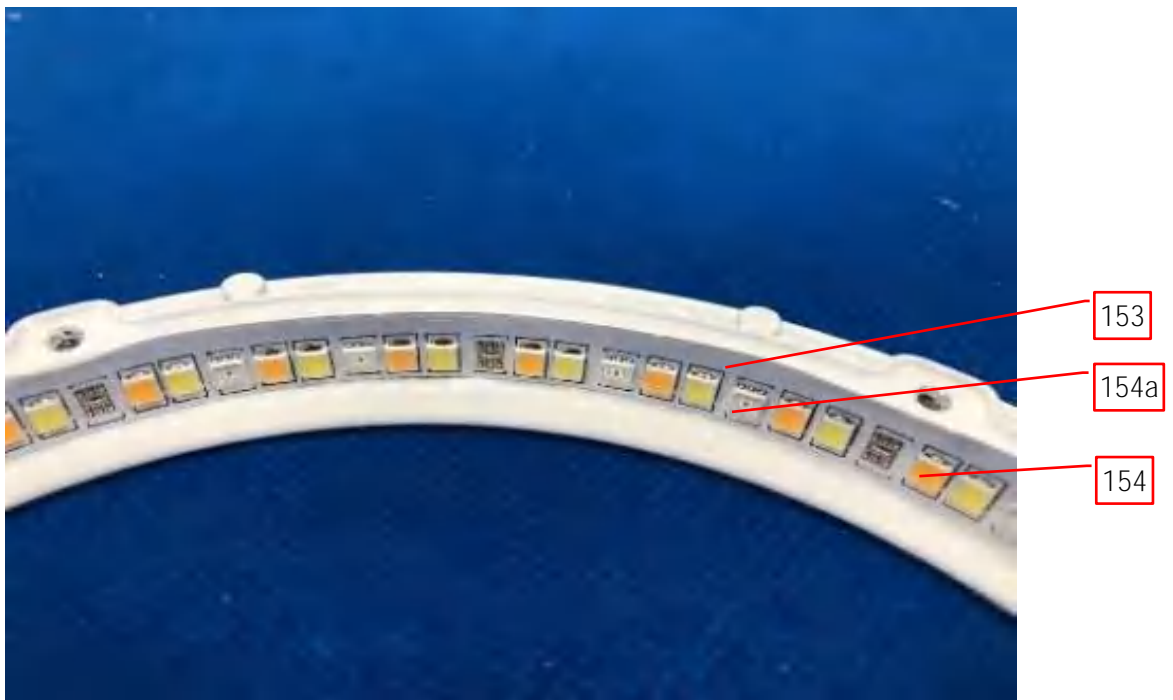


**3.0 Product Photographs**

**Photo 268** - Internal view of JXL-TZ06-T12W-RGBCW

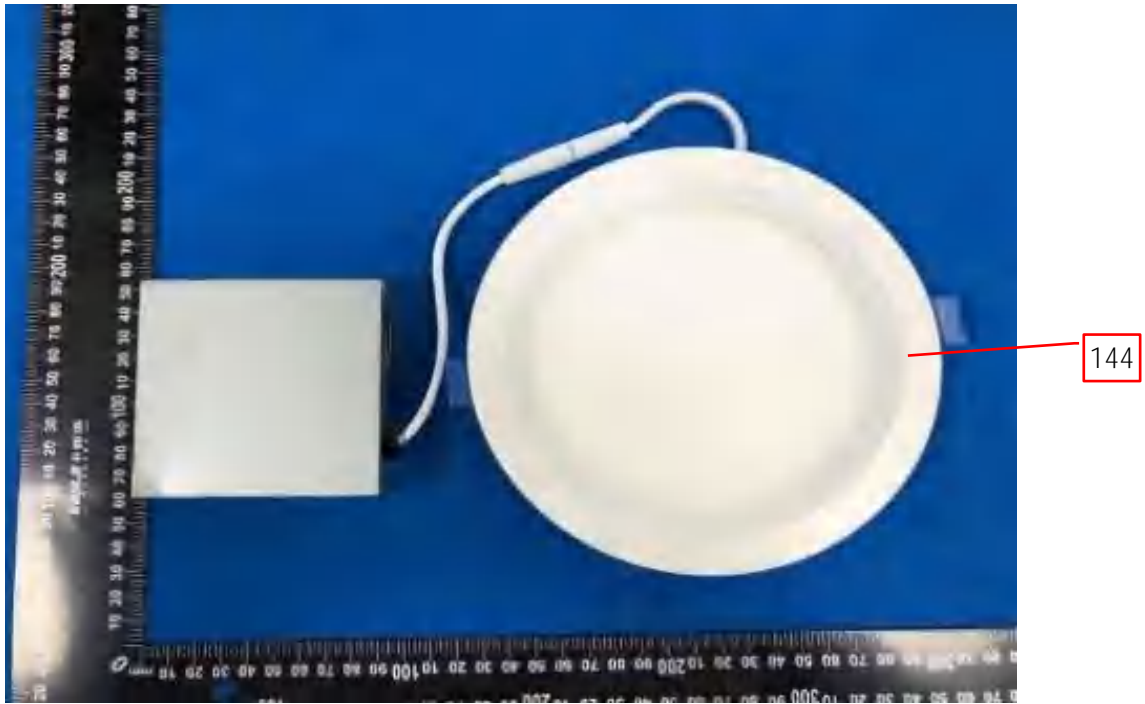


**Photo 269** - Internal view of JXL-TZ06-T12W-RGBCW

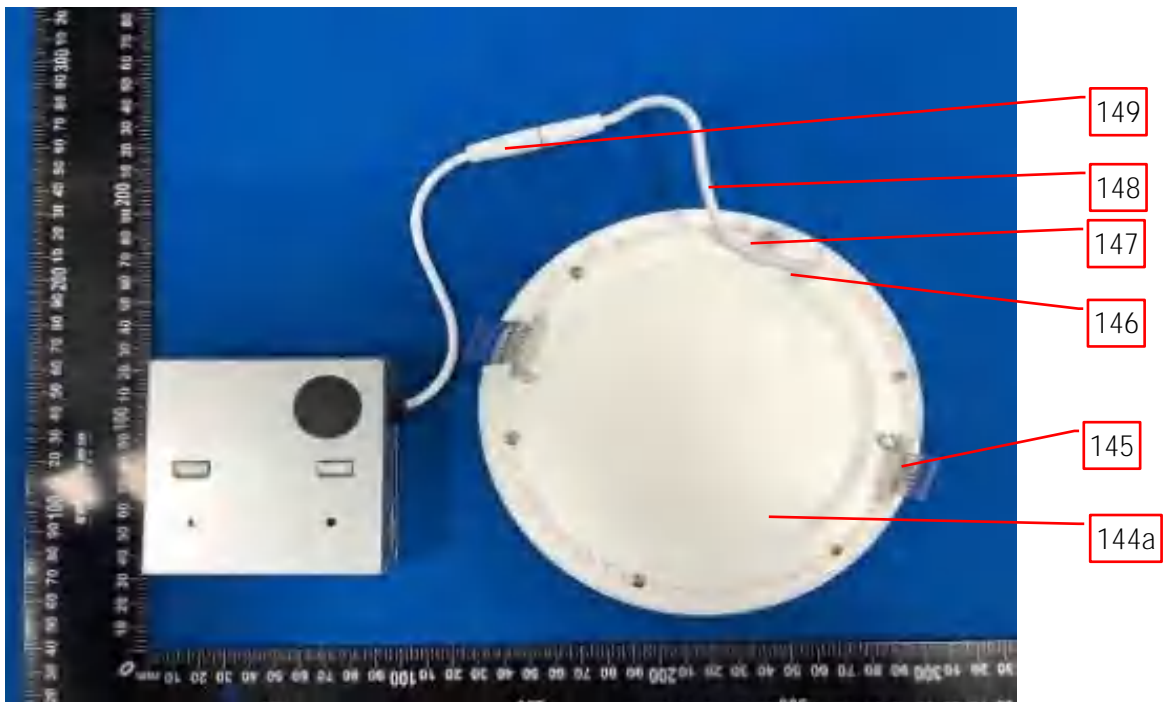


**3.0 Product Photographs**

**Photo 270** - External view of JXL-CA06-T12W-RGBCW



**Photo 271** - Back view of JXL-CA06-T12W-RGBCW

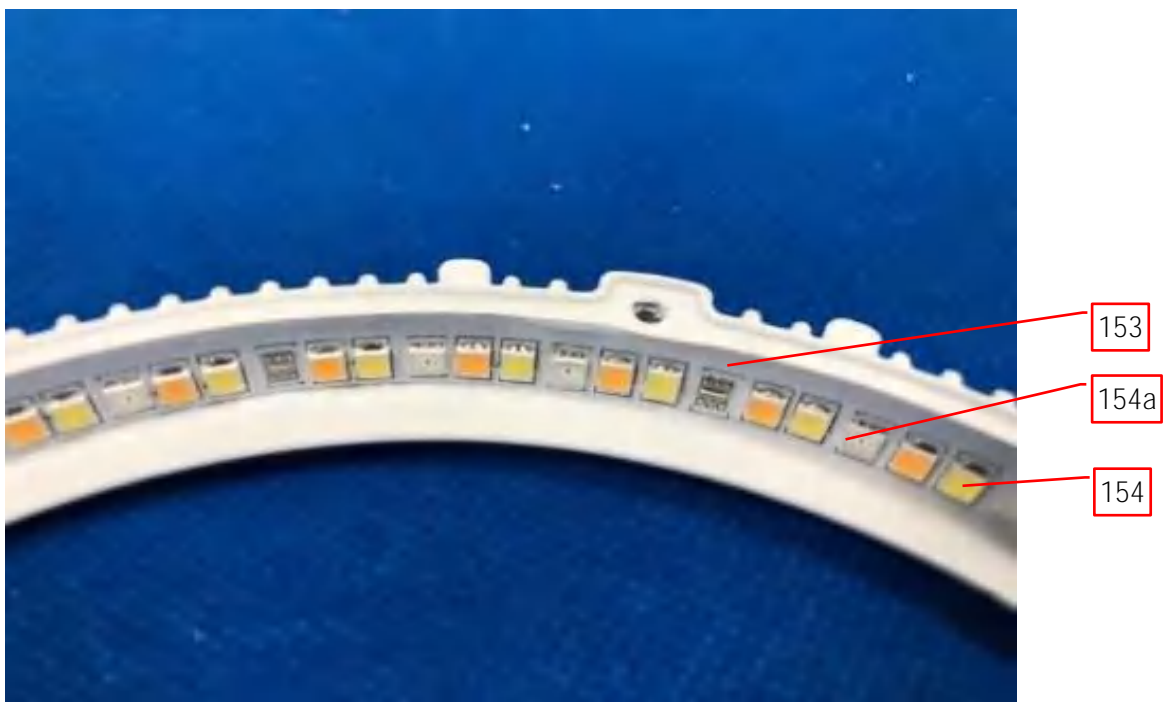


**3.0 Product Photographs**

**Photo 272** - Internal view of JXL-CA06-T12W-RGBCW

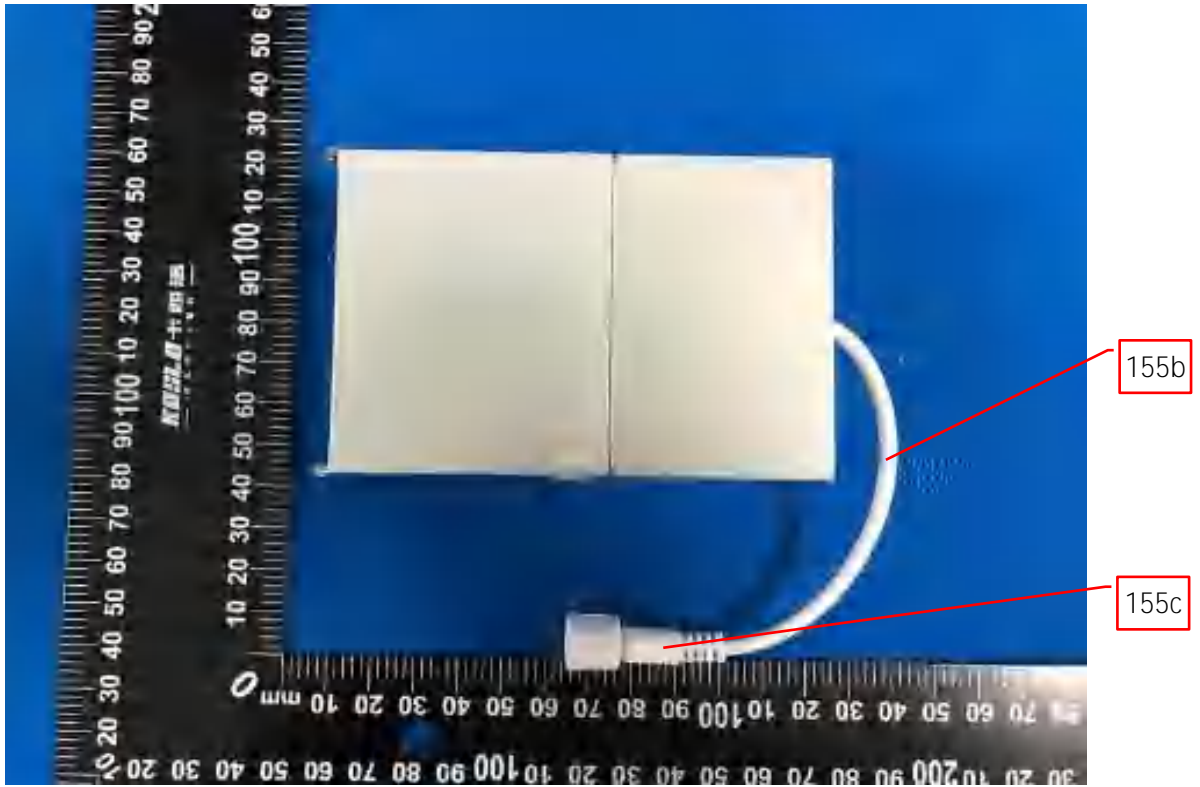


**Photo 273** - Internal view of JXL-CA06-T12W-RGBCW

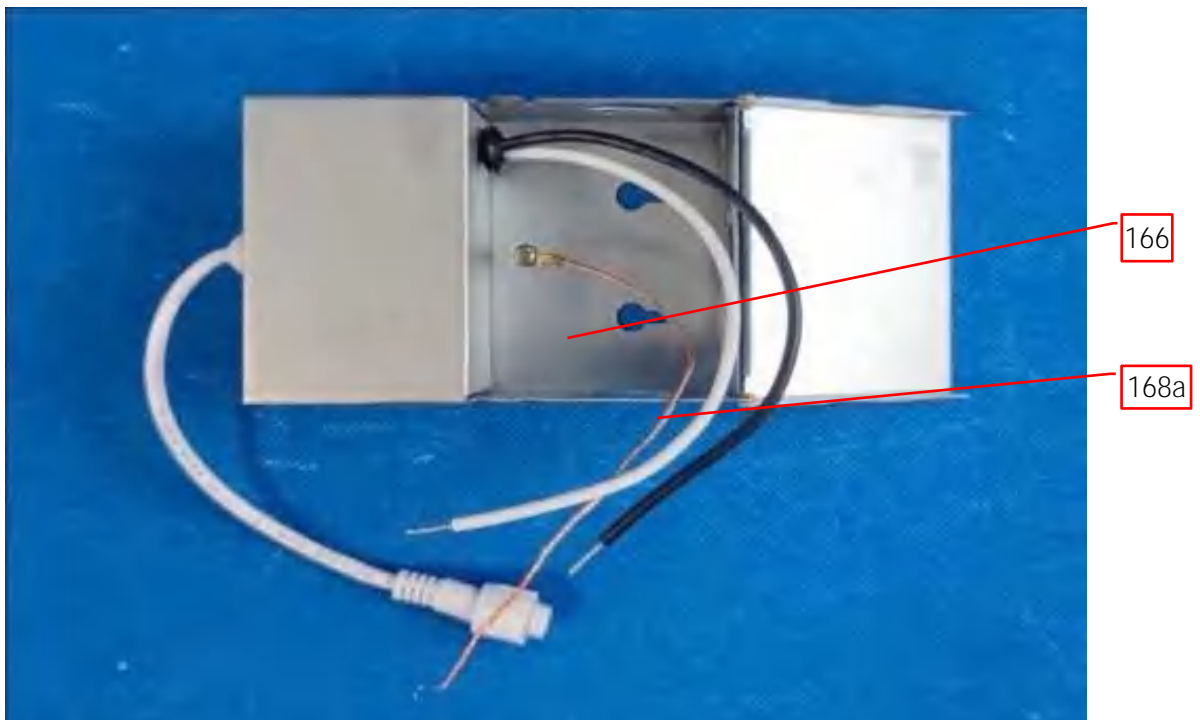


**3.0 Product Photographs**

**Photo 274** - External view of LED Driver TR-125, also represents LED Driver TR-063

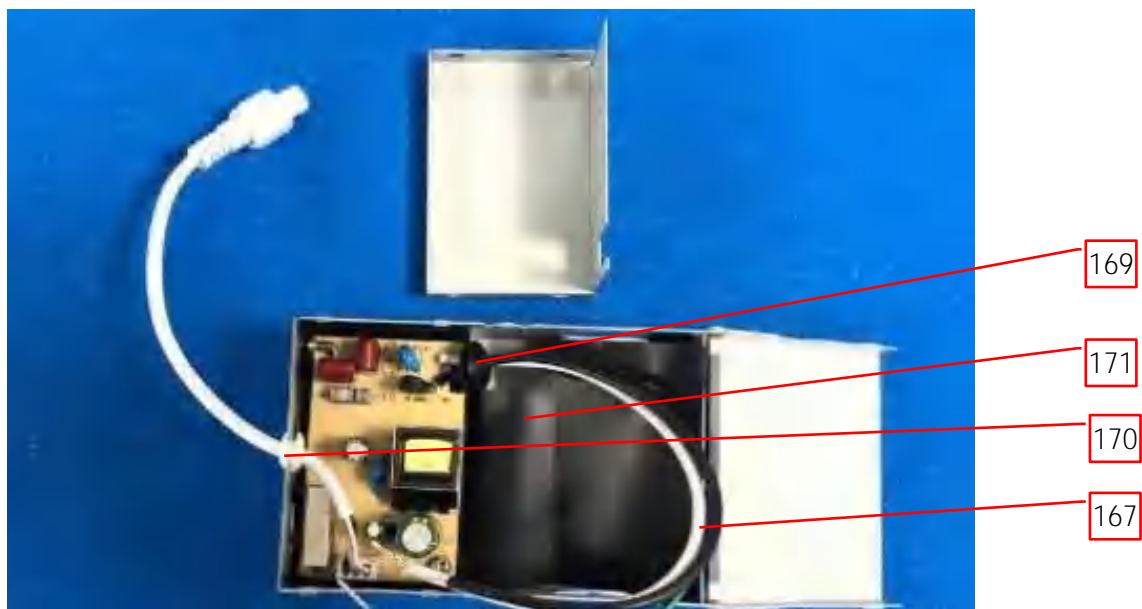


**Photo 275** - Internal view of LED Driver TR-125, also represents LED Driver TR-063

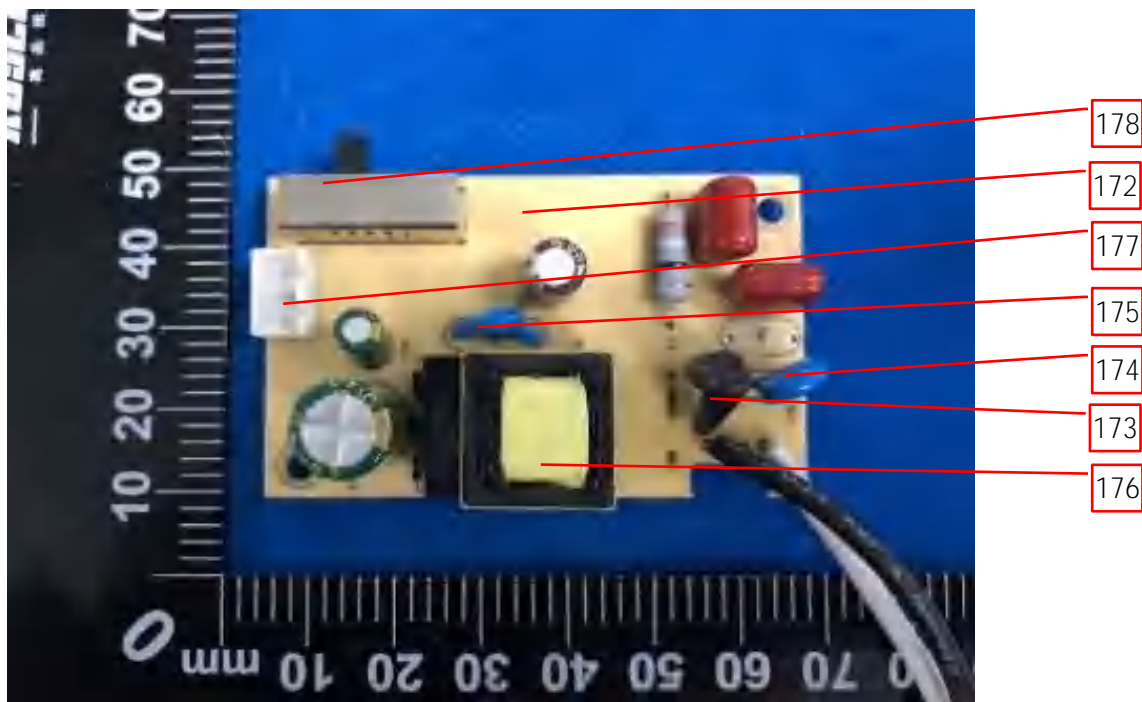


**3.0 Product Photographs**

**Photo 276** - Internal view of LED Driver TR-125, also represents LED Driver TR-063

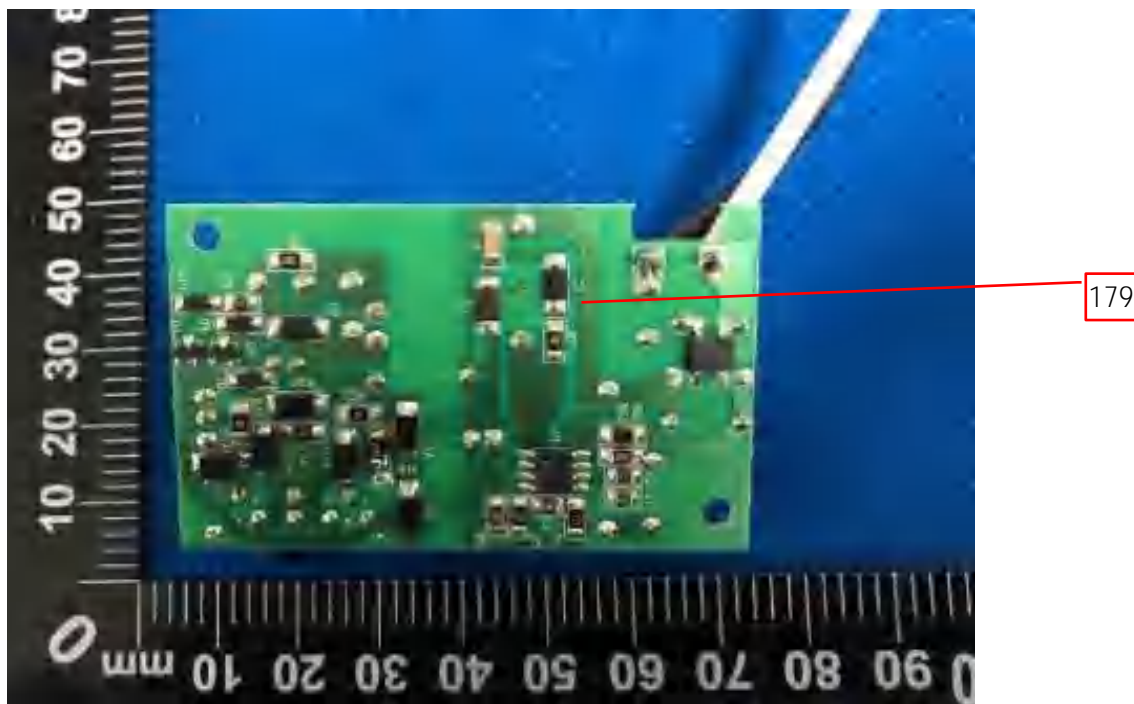


**Photo 277** - PCB assembly of LED driver model TR-125

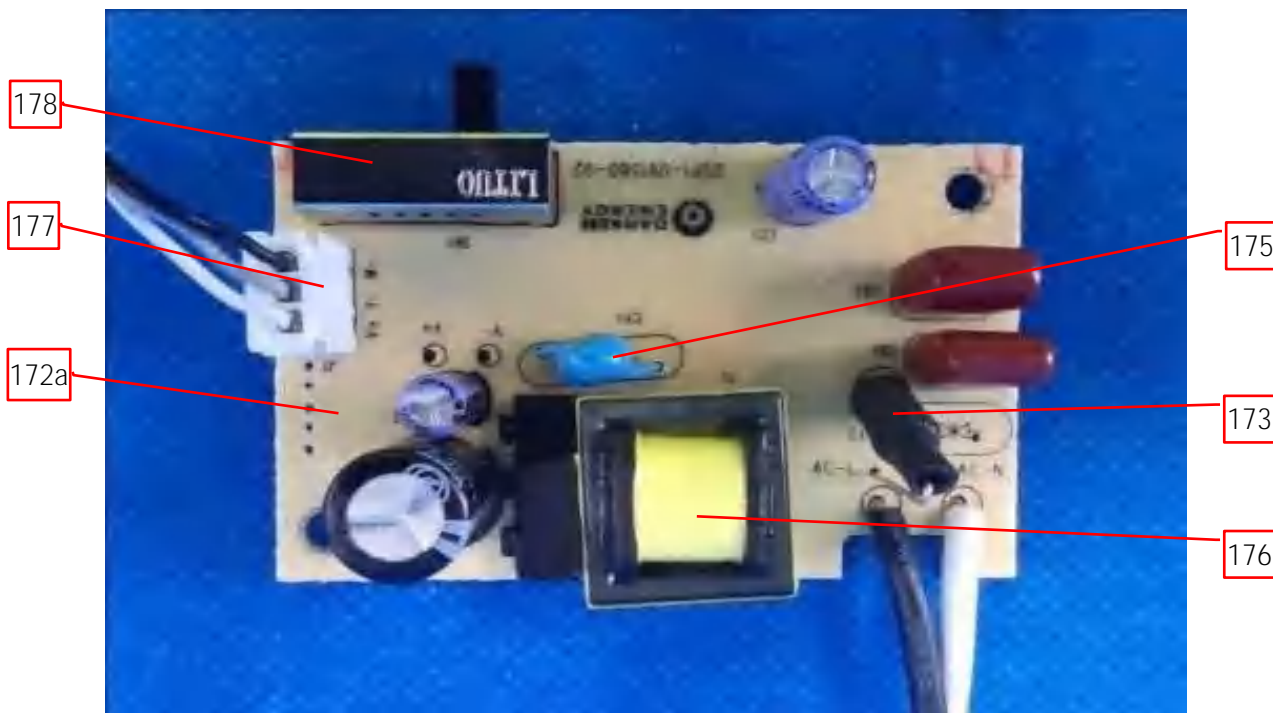


**3.0 Product Photographs**

**Photo 278** - PCB assembly of LED driver model TR-125

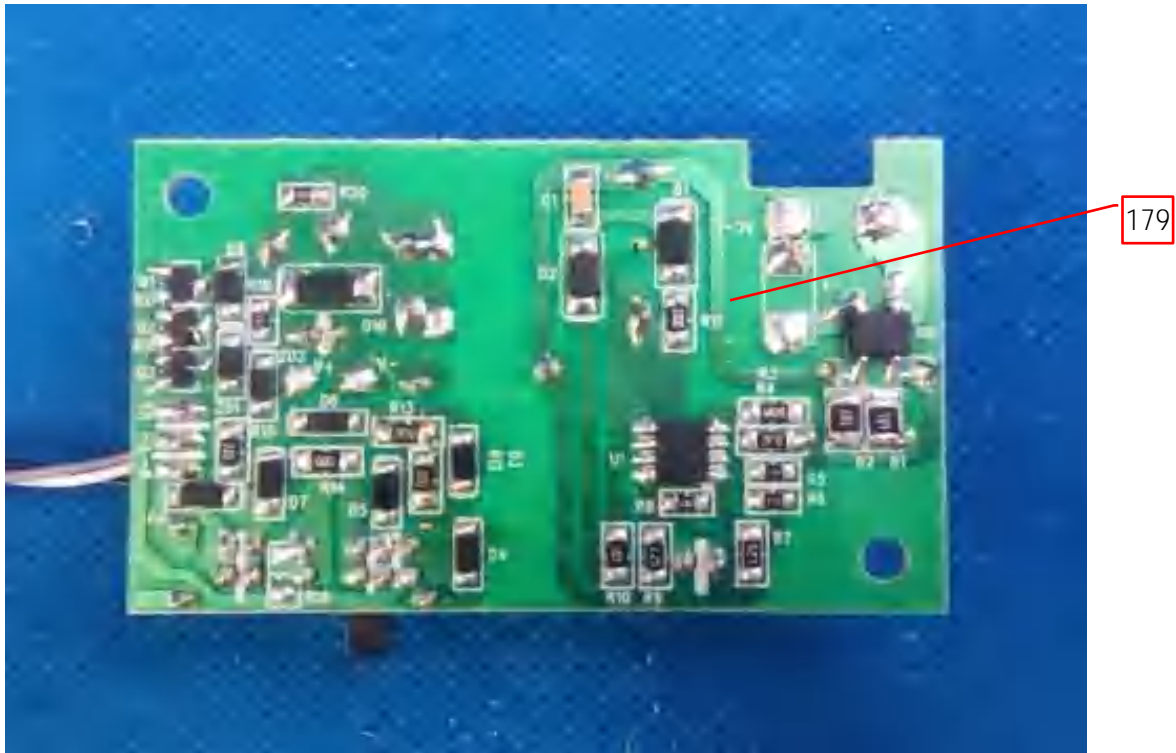


**Photo 278a** - Top View of PCB assembly of LED driver model TR-063

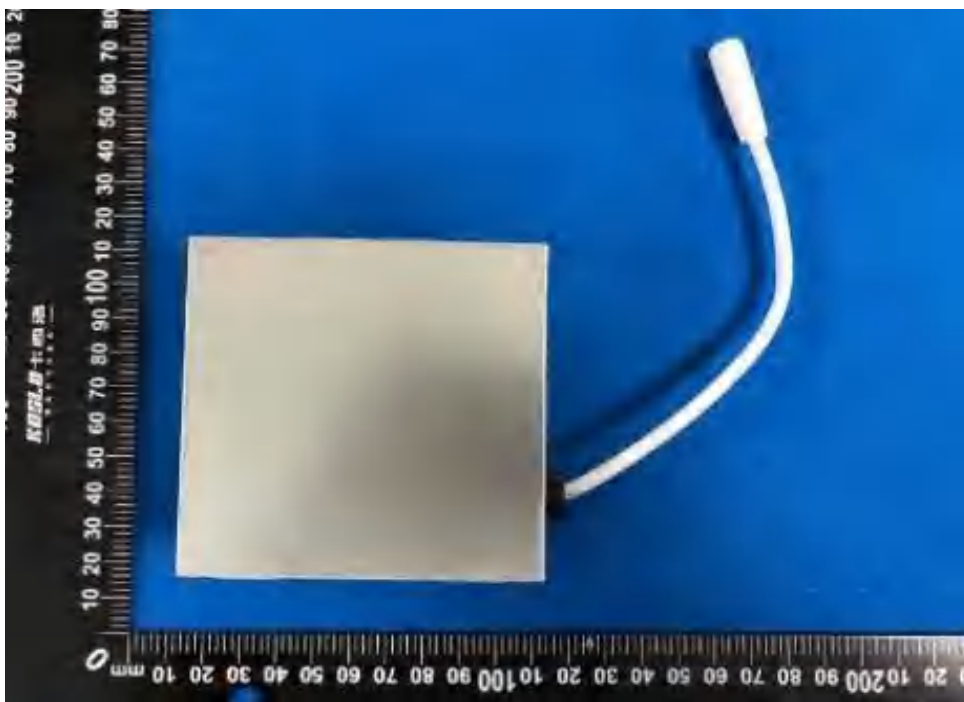


**3.0 Product Photographs**

**Photo 278b** - Bottom View of PCB assembly of LED driver model TR-063

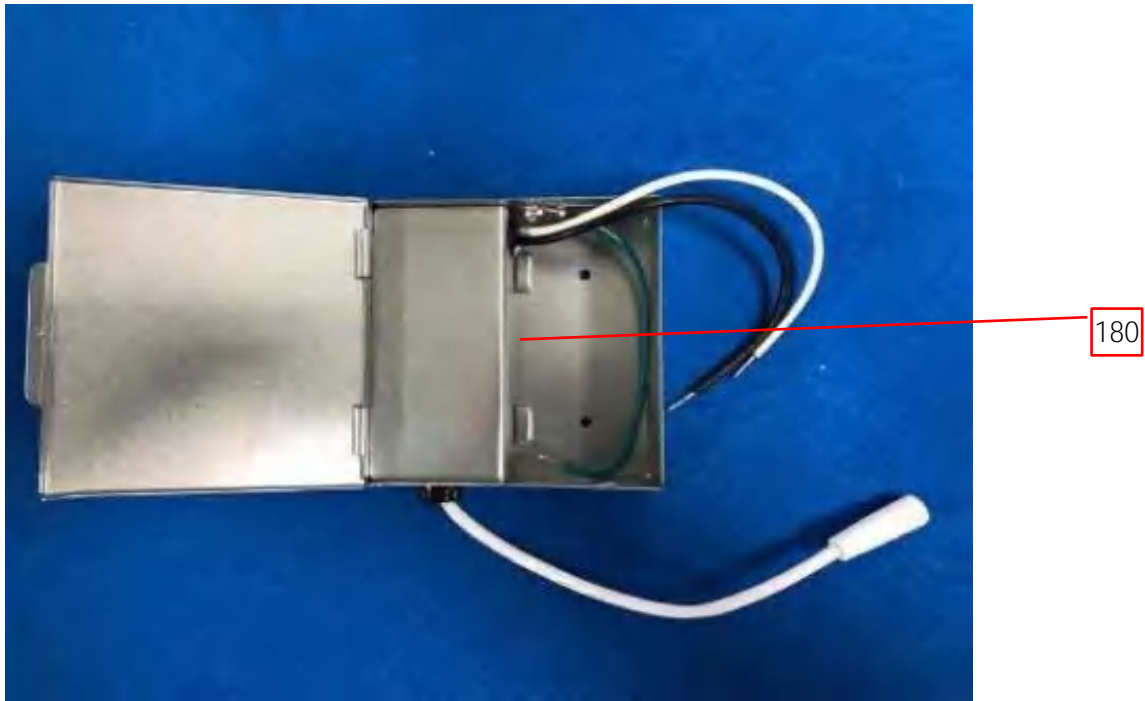


**Photo 279** - External view of LED Driver 10-12W

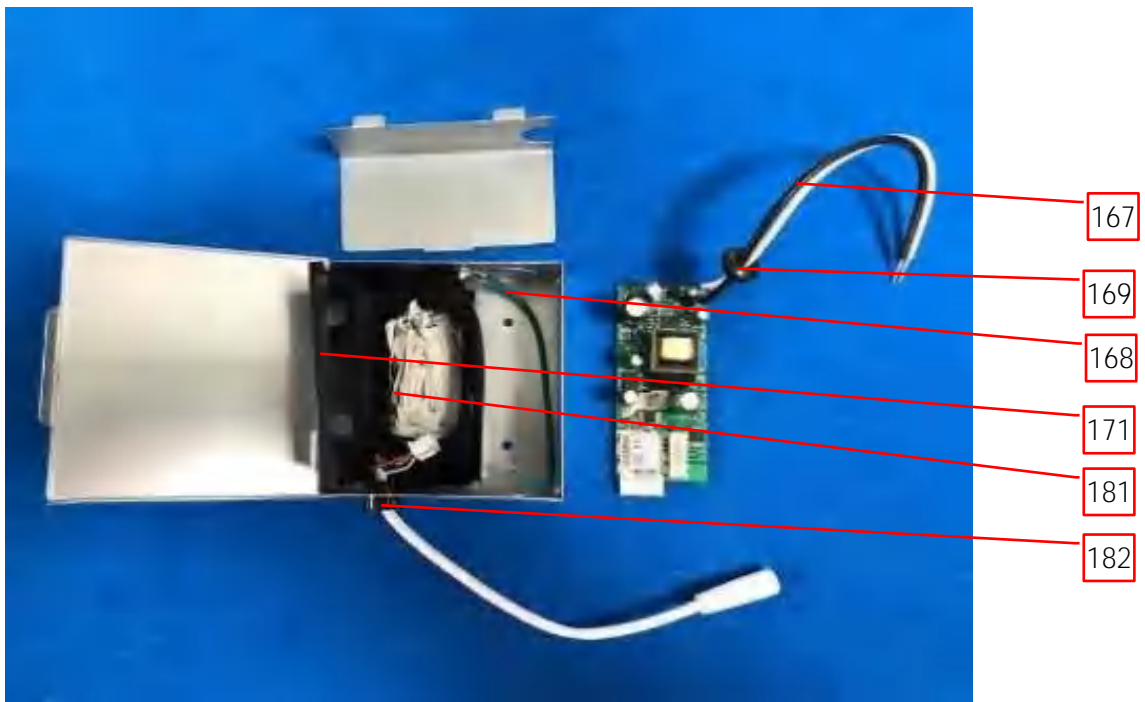


**3.0 Product Photographs**

**Photo 280** - Internal view of LED Driver TR-053 and TR-054

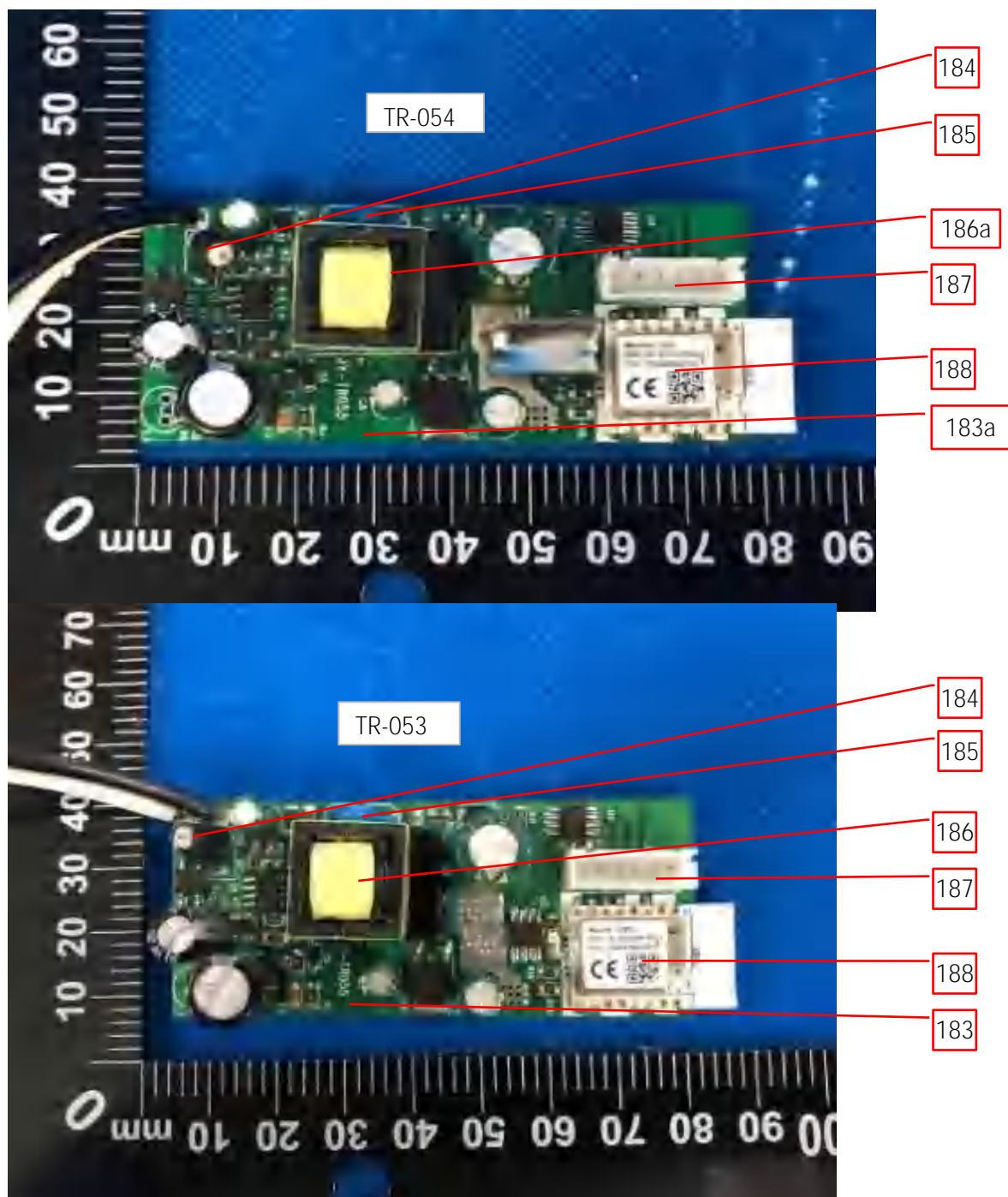


**Photo 281** - Internal view of LED Driver TR-053 and TR-054



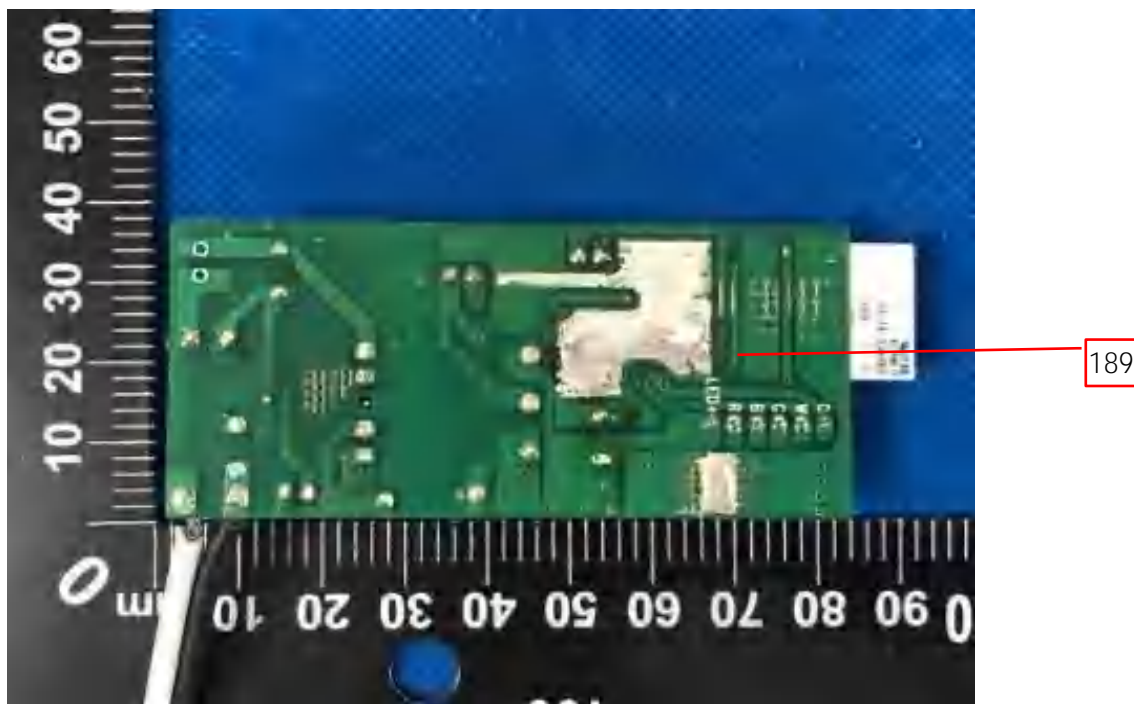
**3.0 Product Photographs**

**Photo 282 - PCB assembly of LED driver model TR-053 and TR-054**



**3.0 Product Photographs**

**Photo 283** - PCB assembly of LED driver model TR-053 and TR-054

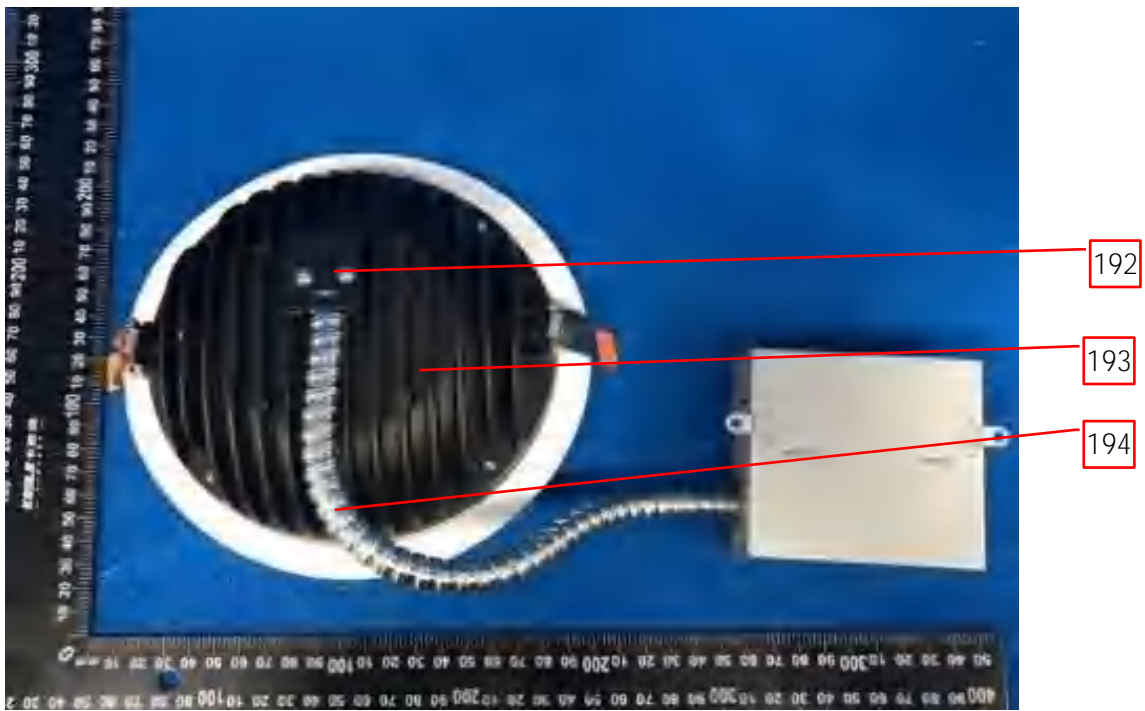


**Photo 284** - External view of JXL-TEH06-T18W-UDN-XX



**3.0 Product Photographs**

**Photo 285 - Back view of JXL-TEH06-T18W-UDN-XX**

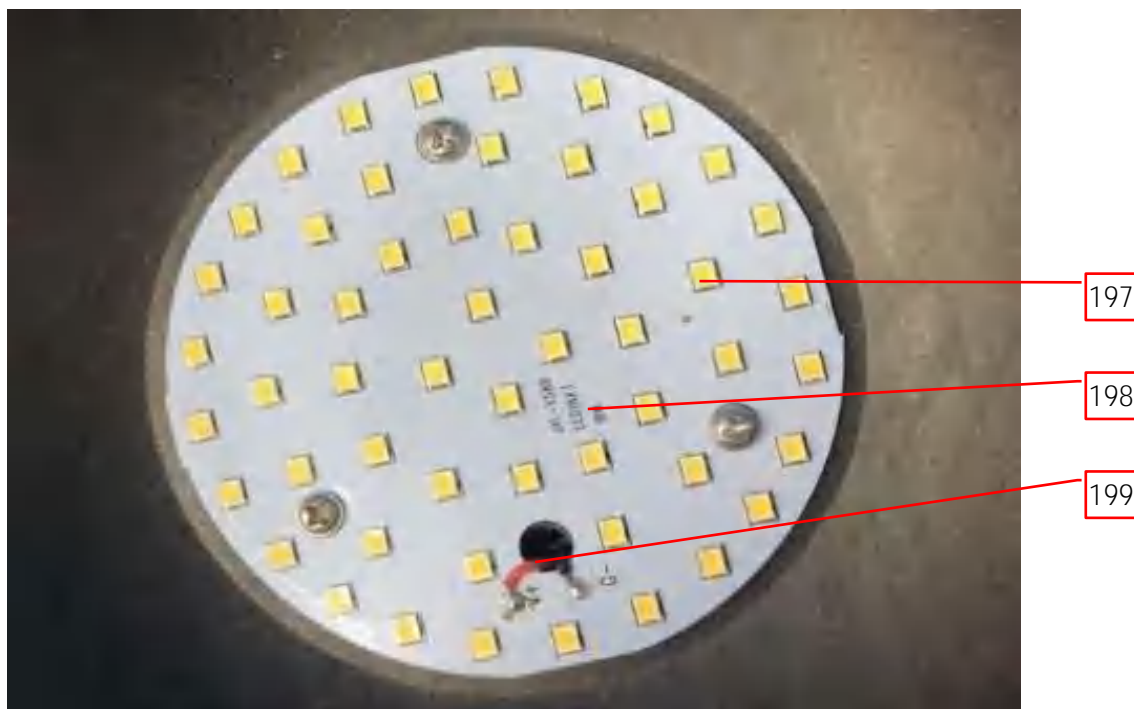


**Photo 286 - Internal view of JXL-TEH06-T18W-UDN-XX**

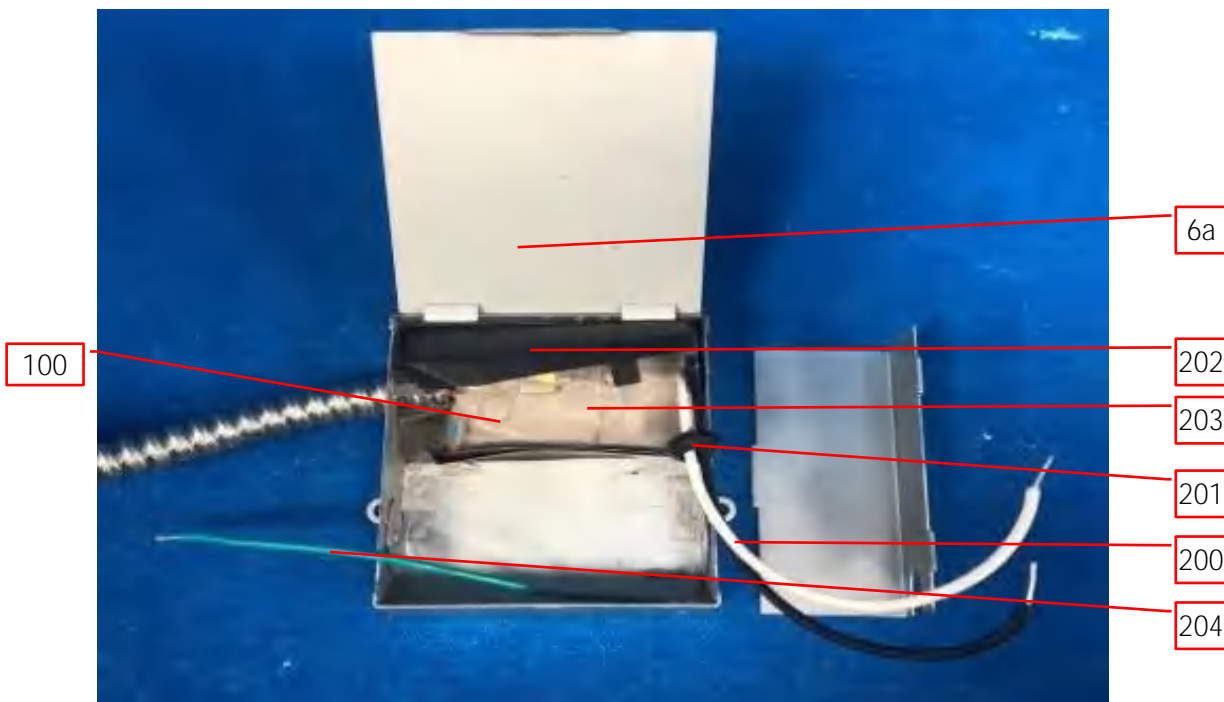


**3.0 Product Photographs**

**Photo 287** - Internal view of JXL-TEH06-T18W-UDN-XX

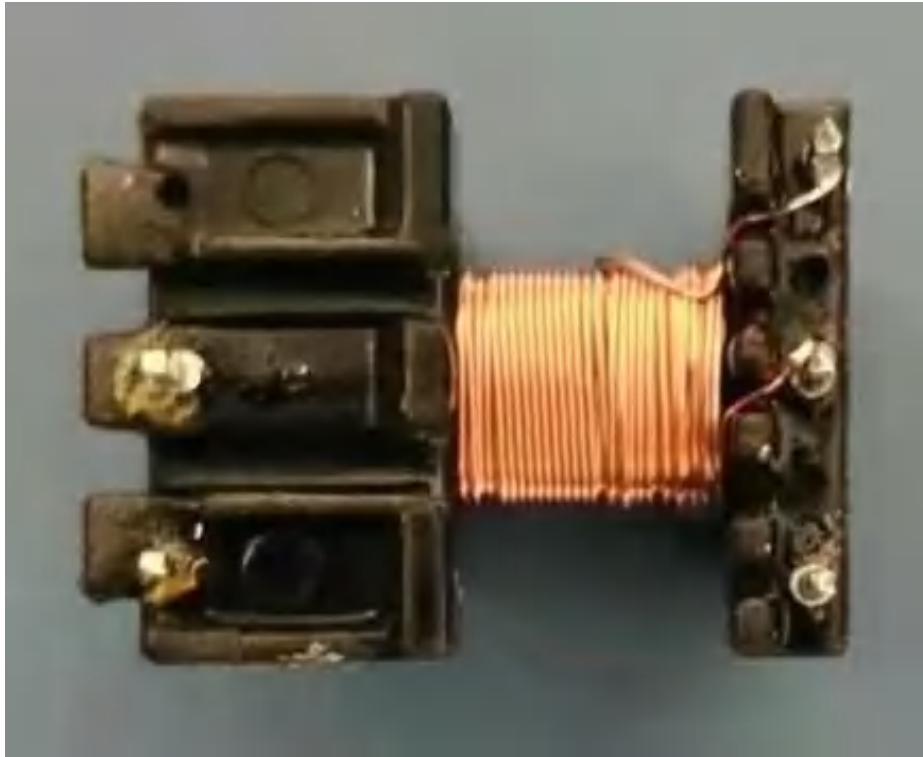


**Photo 288** - Internal view of junction box for model JXL-TEH06-T18W-UDN-XX

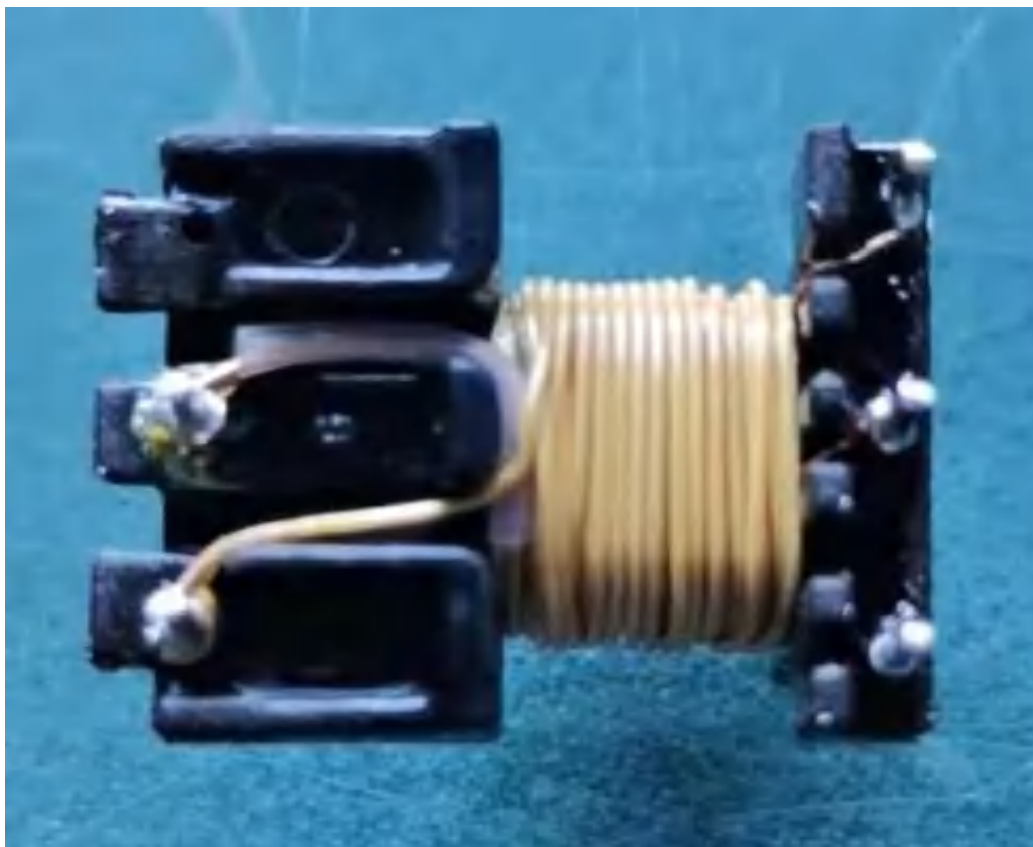


### 3.0 Product Photographs

**Photo 289** - Transformer (T1) construction of driver TR-125



**Photo 290**- Transformer (T1) construction of driver TR-125



### 3.0 Product Photographs

**Photo 291-** Transformer (T1) construction of driver TR-053 and TR-054

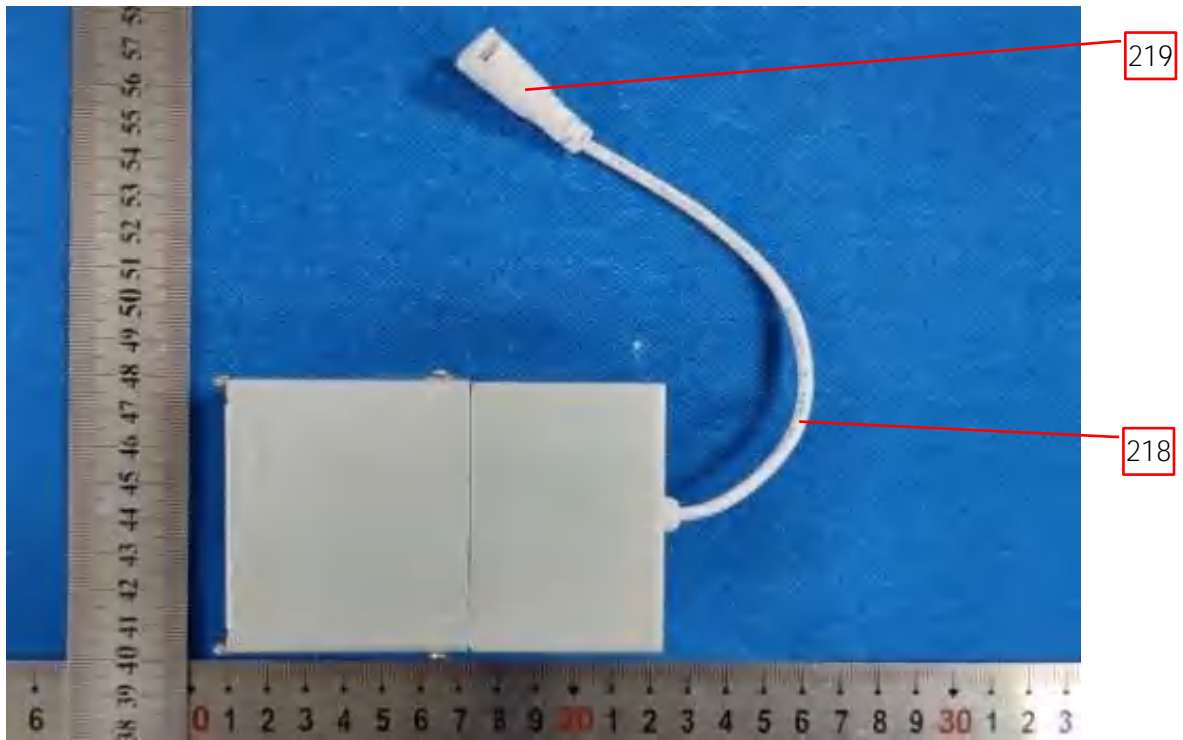


**Photo 292-** Transformer (T1) construction of driver TR-053 and TR-054

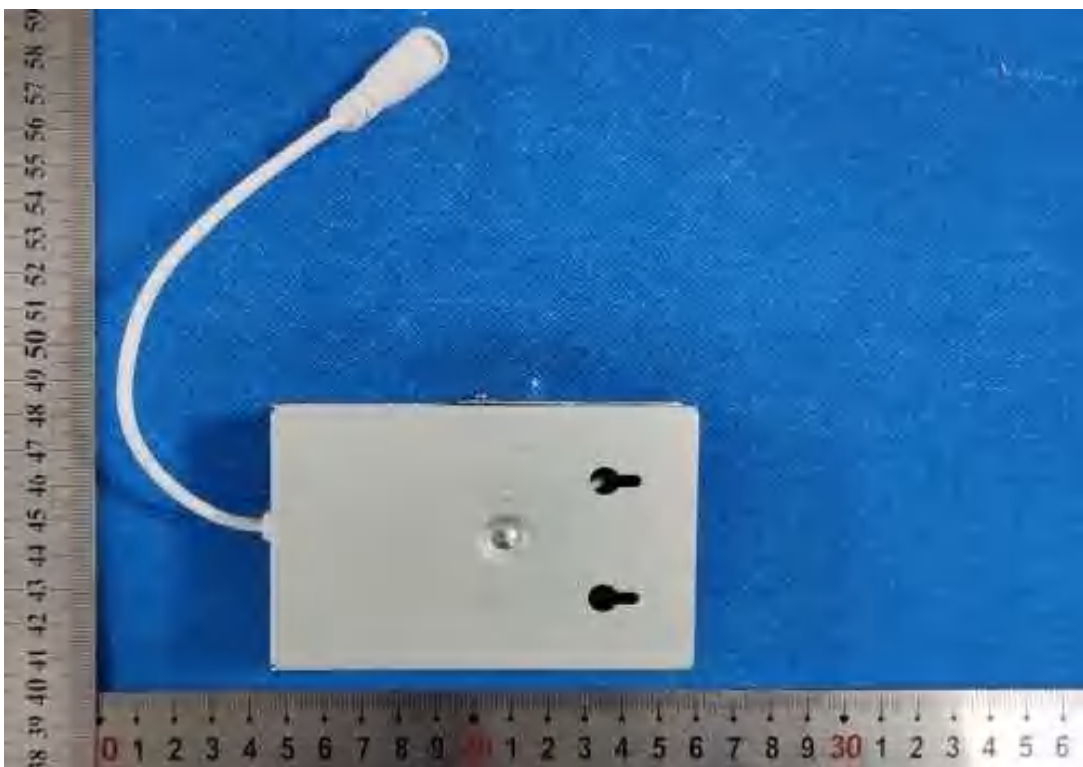


**3.0 Product Photographs**

**Photo 293** - External Top View of LED Driver TR-319

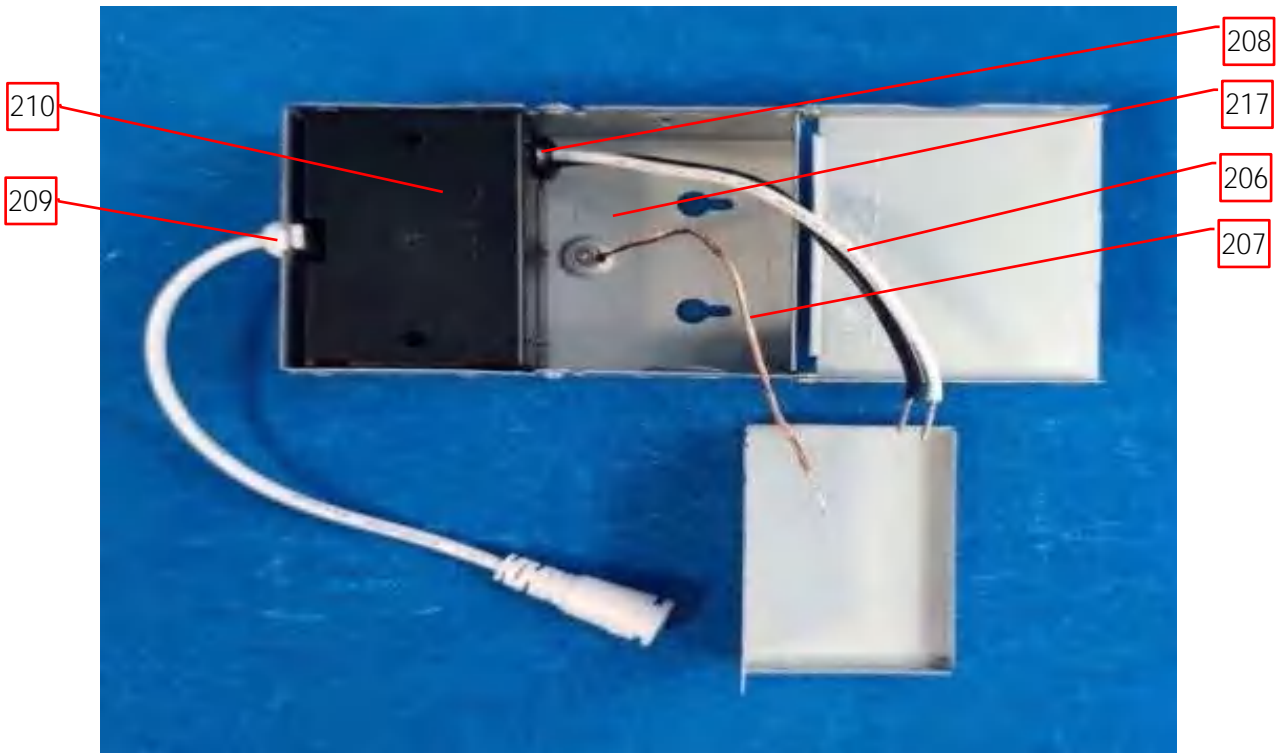


**Photo 294** - External Bottom View of LED Driver TR-319

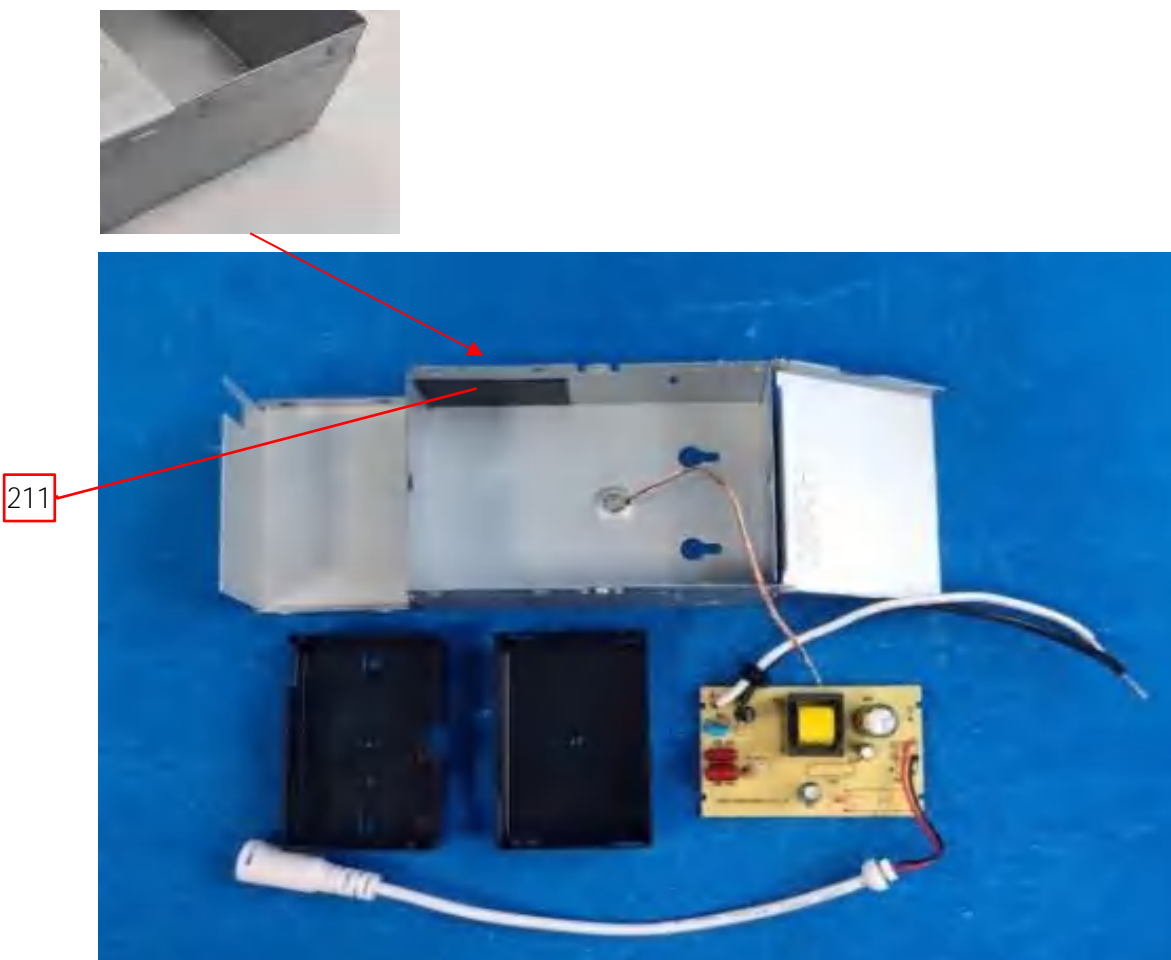


**3.0 Product Photographs**

**Photo 295** - Internal View-1 of LED Driver TR-319

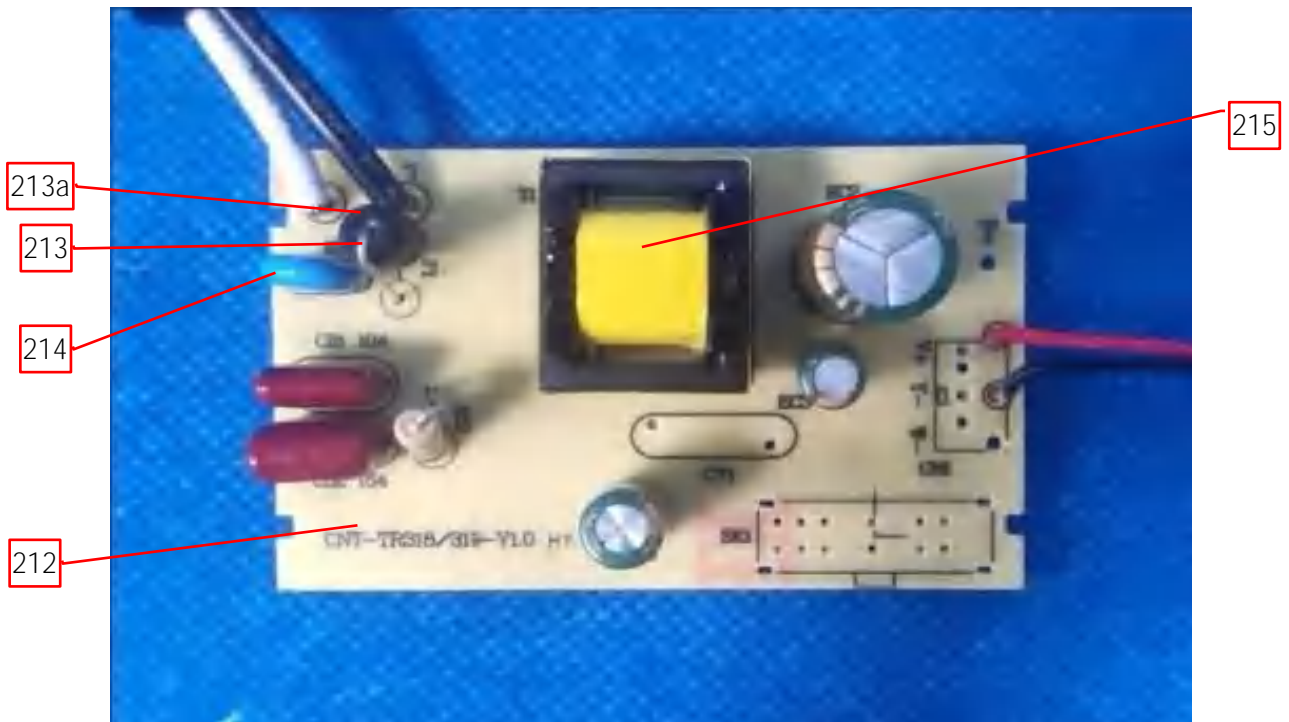


**Photo 296** - Internal View-2 of LED Driver TR-319

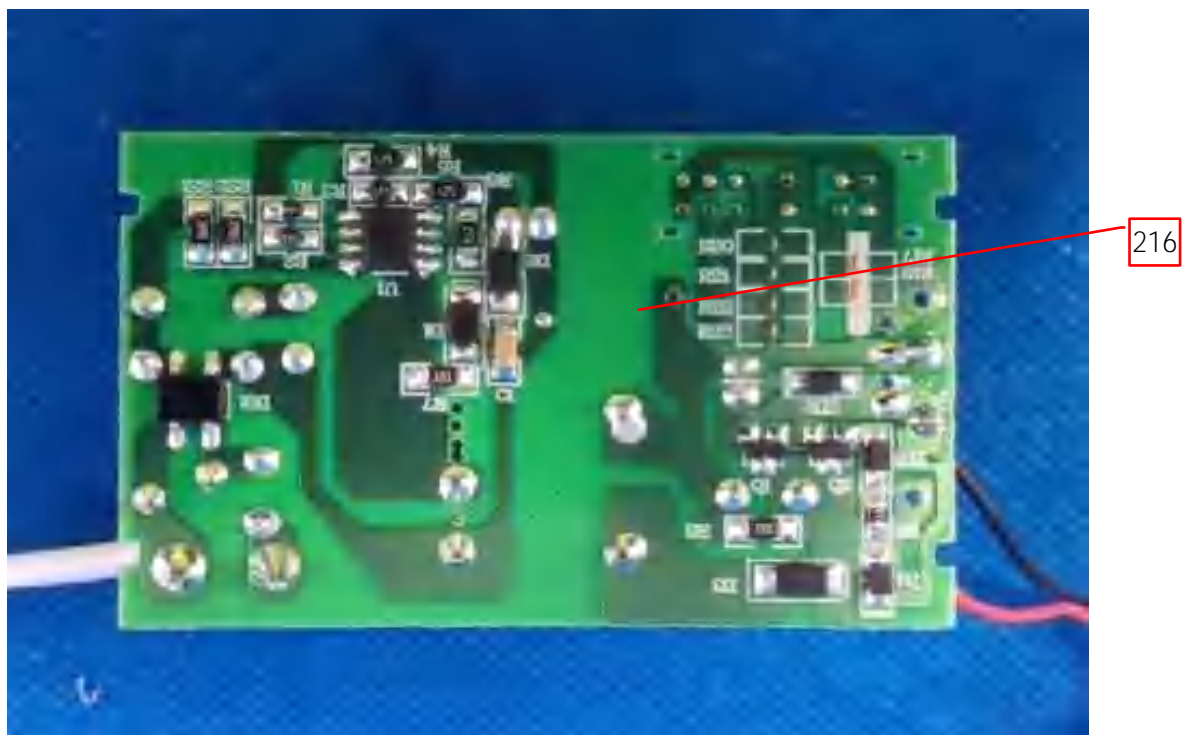


**3.0 Product Photographs**

**Photo 297 - PCB Assembly Top View of LED Driver TR-319**

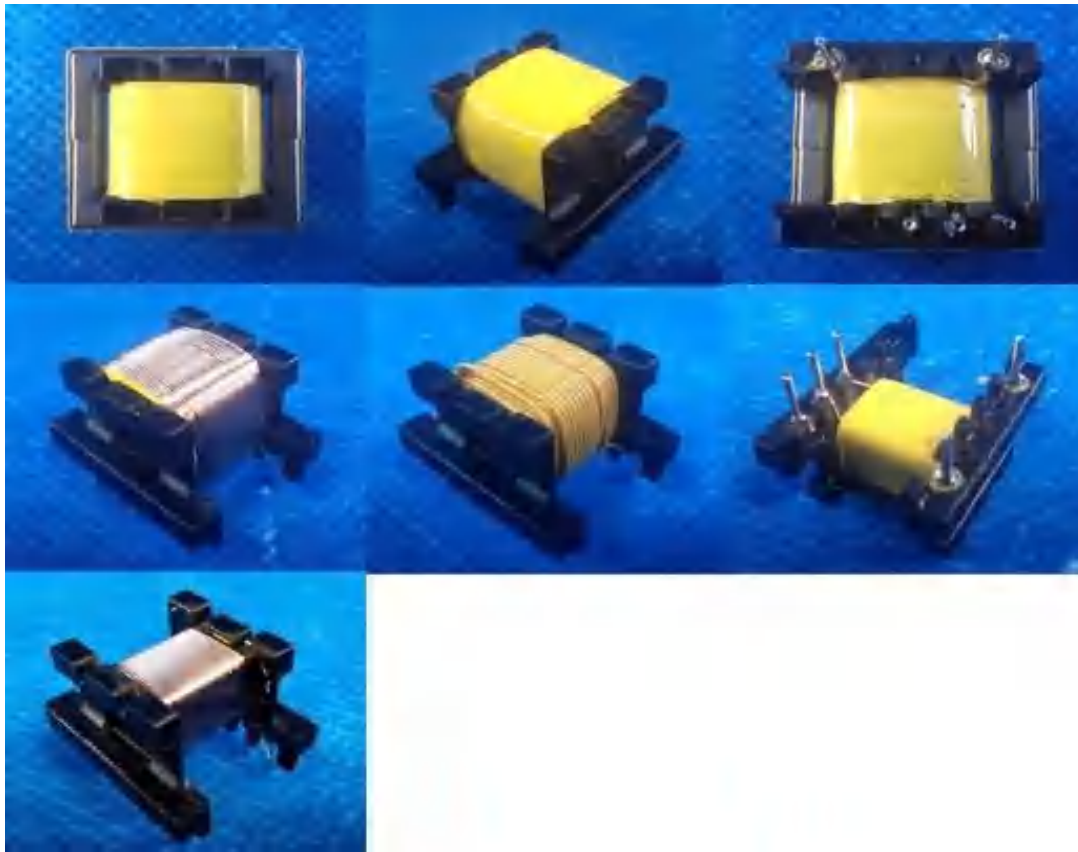


**Photo 298 - PCB Assembly Bottom View of LED Driver TR-319**



**3.0 Product Photographs**

**Photo 299** - Transformer View of LED Driver TR-319

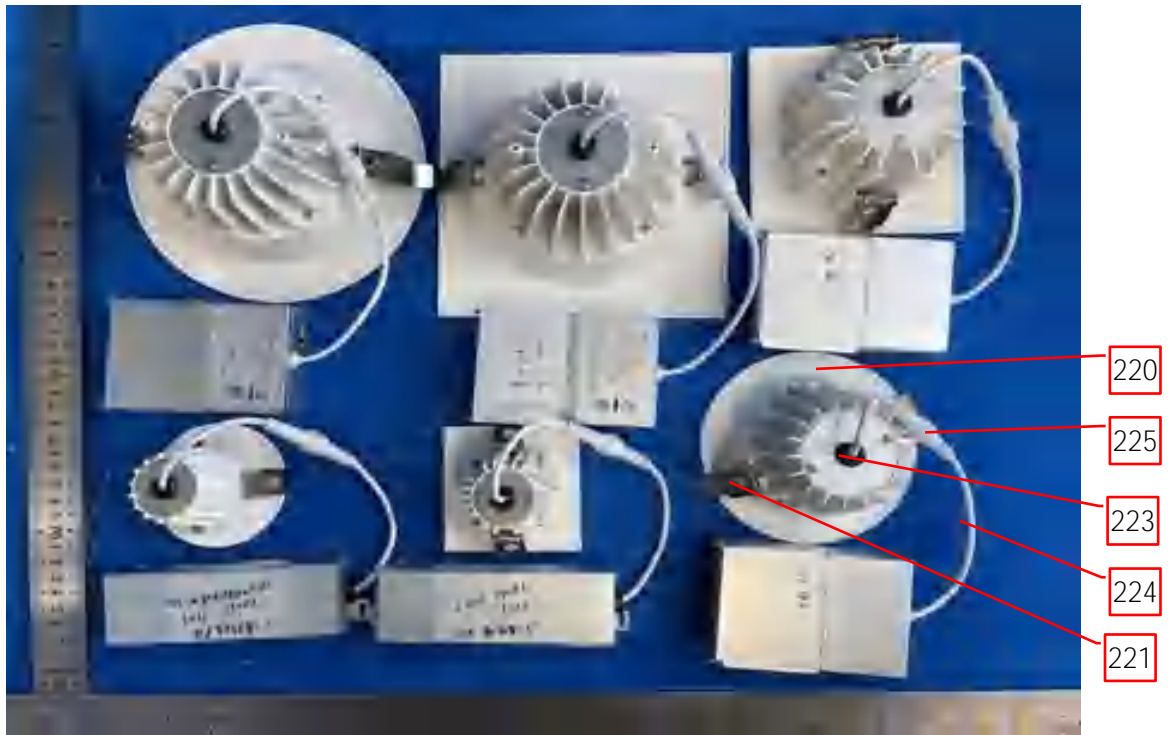


**Photo 300** - External view of JXL-COB02-R9W-5CCT, JXL-COB02-S9W-5CCT, JXL-COB04-R12W-5CCT, JXL-COB04-S12W-5CCT, JXL-COB04-R15W-5CCT, JXL-COB04-S15W-5CCT, JXL-COB06-R15W-5CCT and JXL-COB06-S15W-5CCT

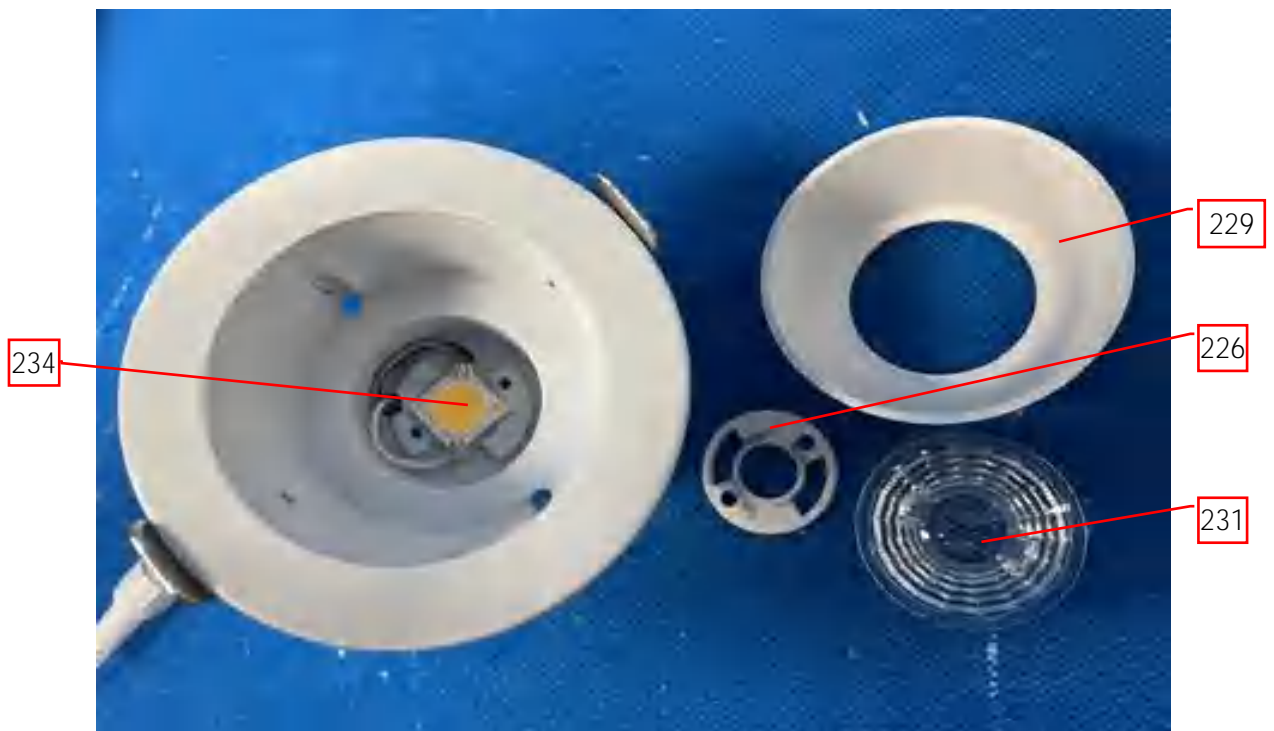


### 3.0 Product Photographs

**Photo 301** - Back view of JXL-COB02-R9W-5CCT, JXL-COB02-S9W-5CCT, JXL-COB04-R12W-5CCT, JXL-COB04-S12W-5CCT, JXL-COB04-R15W-5CCT, JXL-COB04-S15W-5CCT, JXL-COB06-R15W-5CCT and JXL-COB06-S15W-5CCT

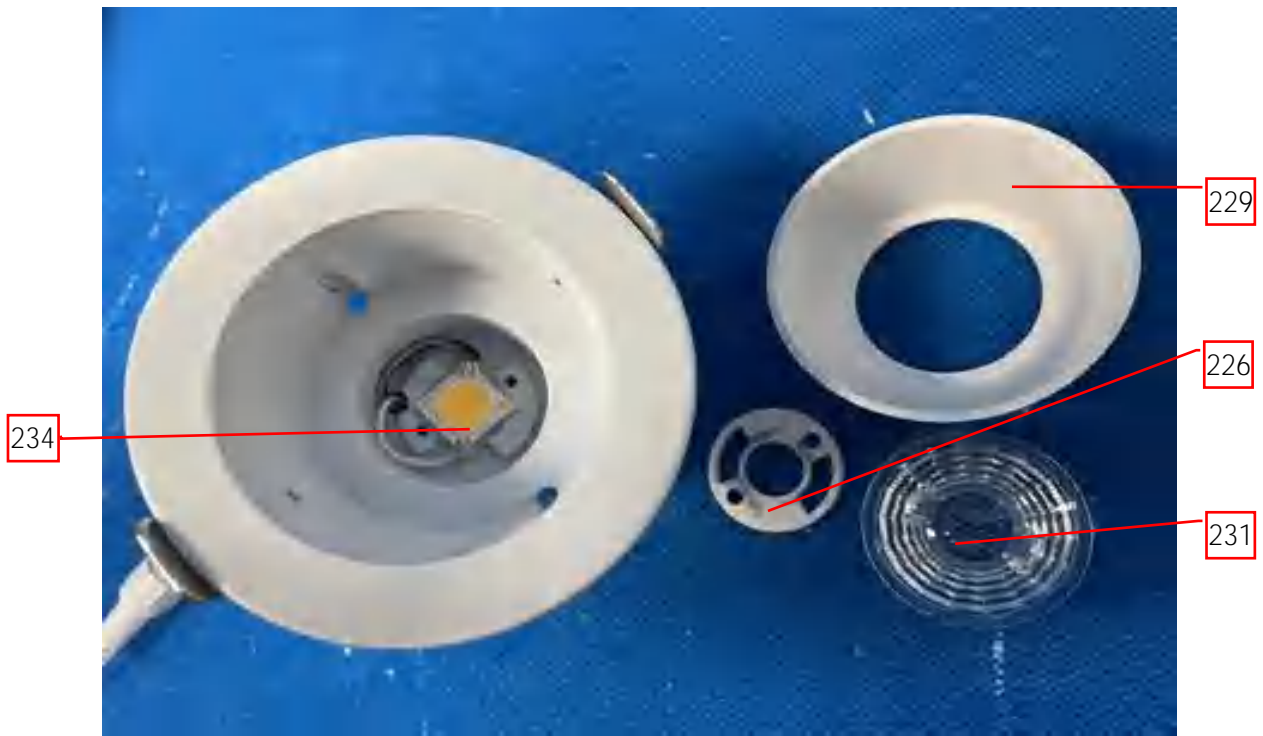


**Photo 302** - Internal view of JXL-COB02-R9W-5CCT and JXL-COB04-R12W-5CCT



**3.0 Product Photographs**

**Photo 303** - Internal view of JXL-COB04-R15W-5CCT

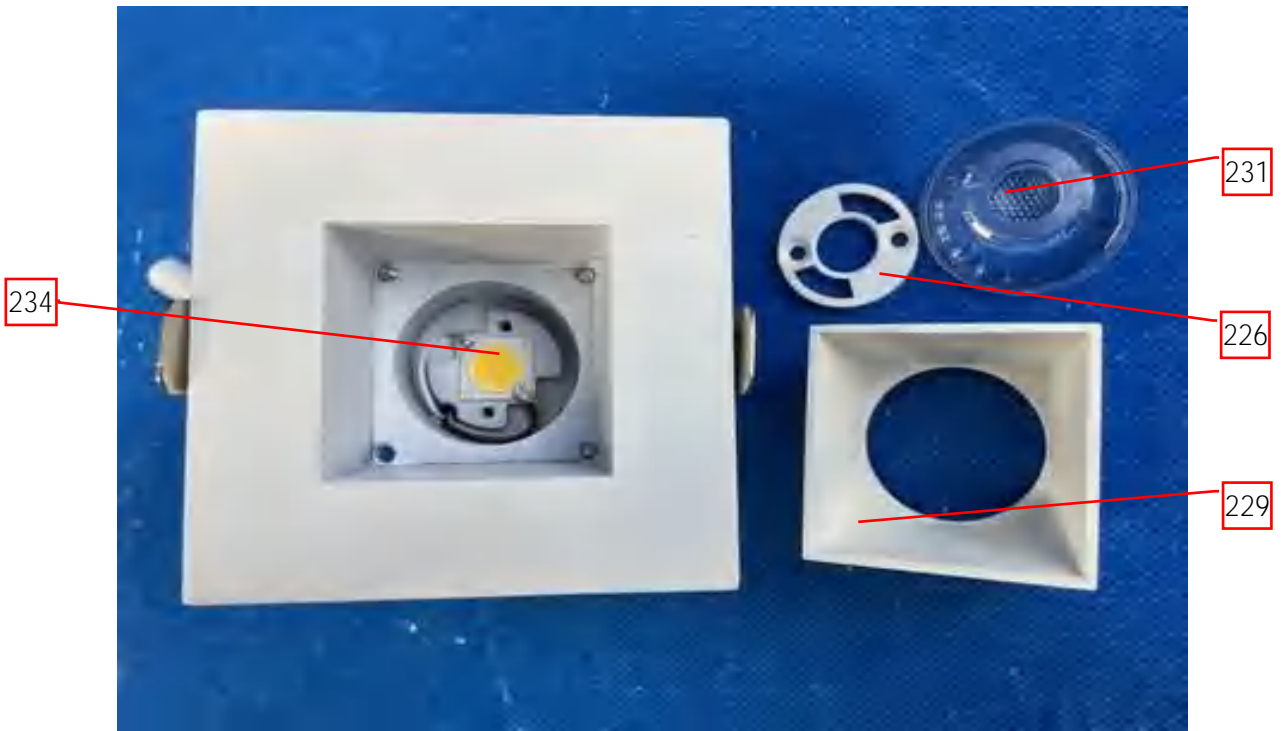


**Photo 304** - Internal view of JXL-COB02-S9W-5CCT and JXL-COB04-S12W-5CCT

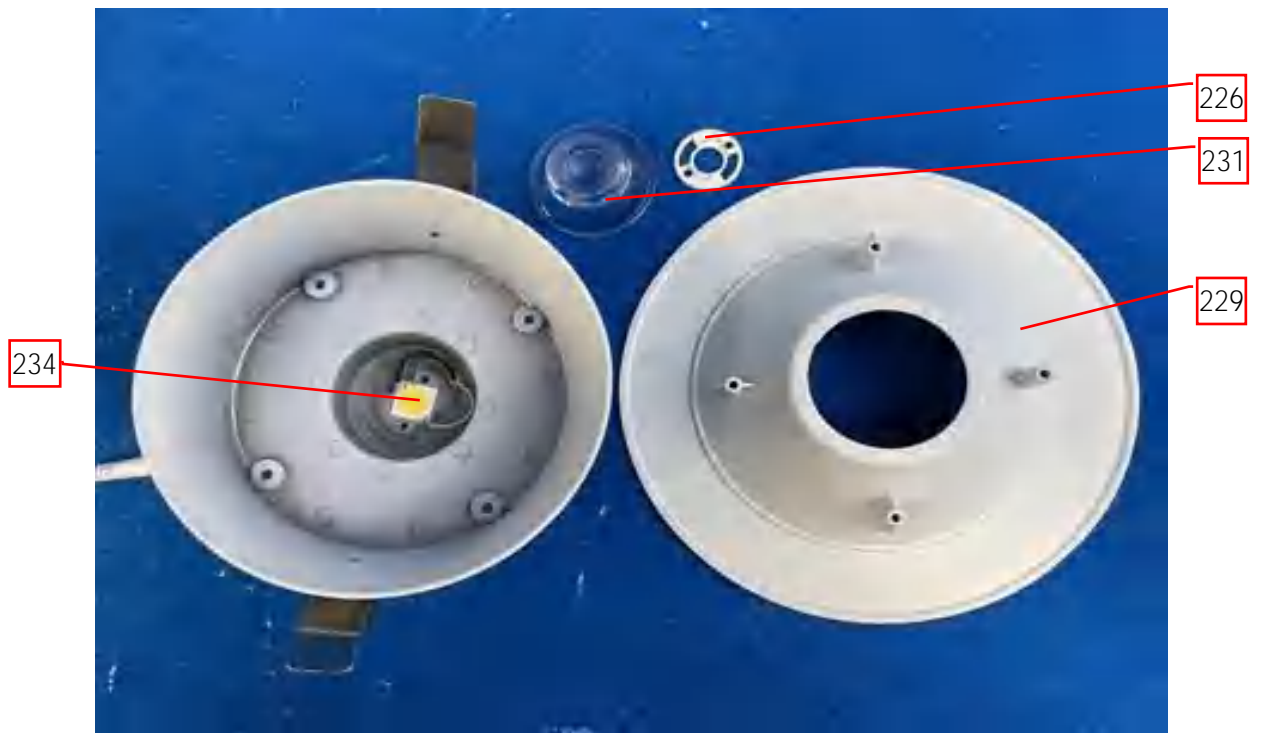


**3.0 Product Photographs**

**Photo 305** - Internal view of JXL-COB04-S15W-5CCT

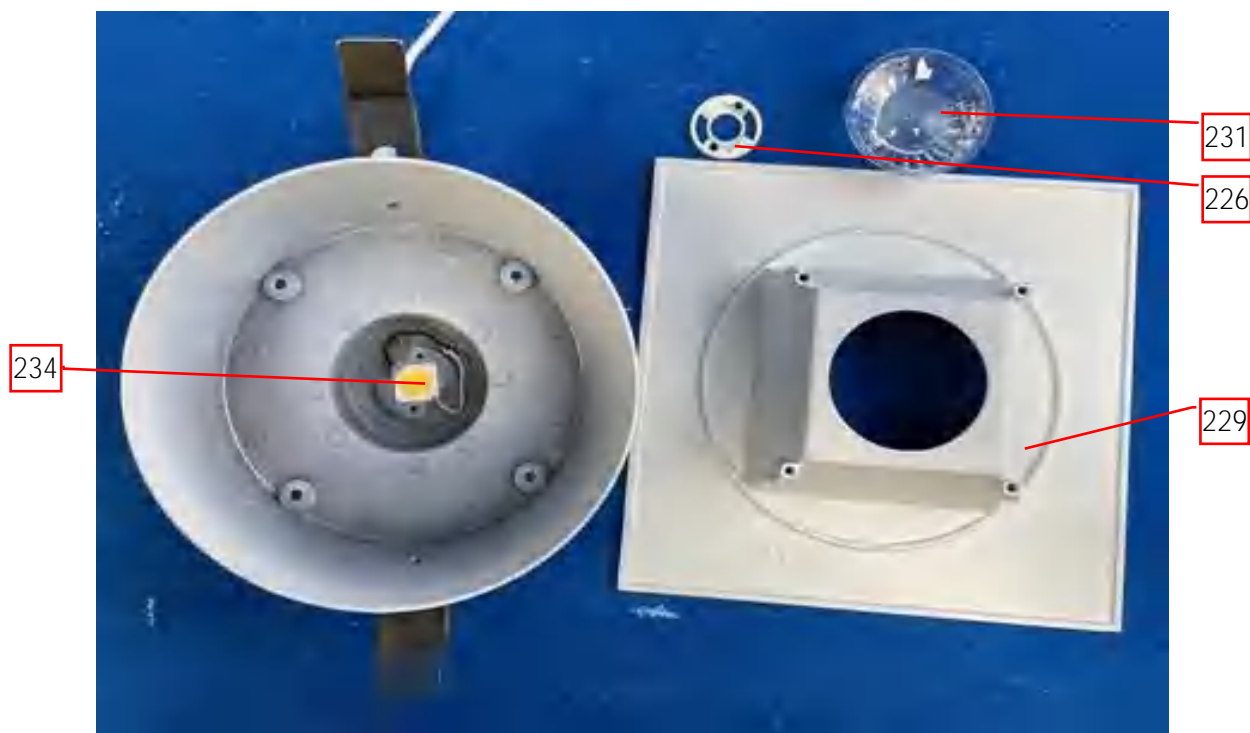


**Photo 306** - Internal view of JXL-COB06-R15W-5CCT



### 3.0 Product Photographs

**Photo 307** - Internal view of JXL-COB06-S15W-5CCT



**Photo 308** - External view of JXL-ZF03-T07W-5CCT and JXL-SMD04-G12W-5CCT



**3.0 Product Photographs**

**Photo 309** - Back view of JXL-ZF03-T07W-5CCT and JXL-SMD04-G12W-5CCT

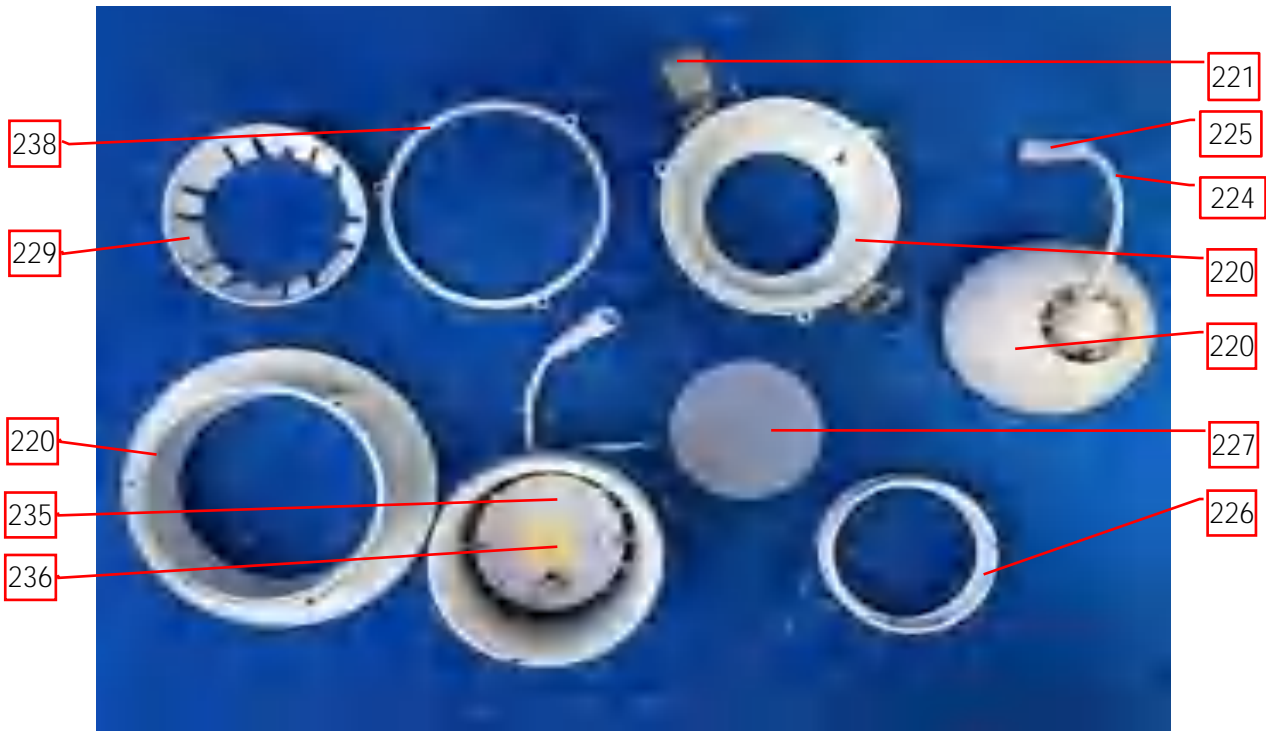


**Photo 310** - Internal view of JXL-ZF03-T07W-5CCT

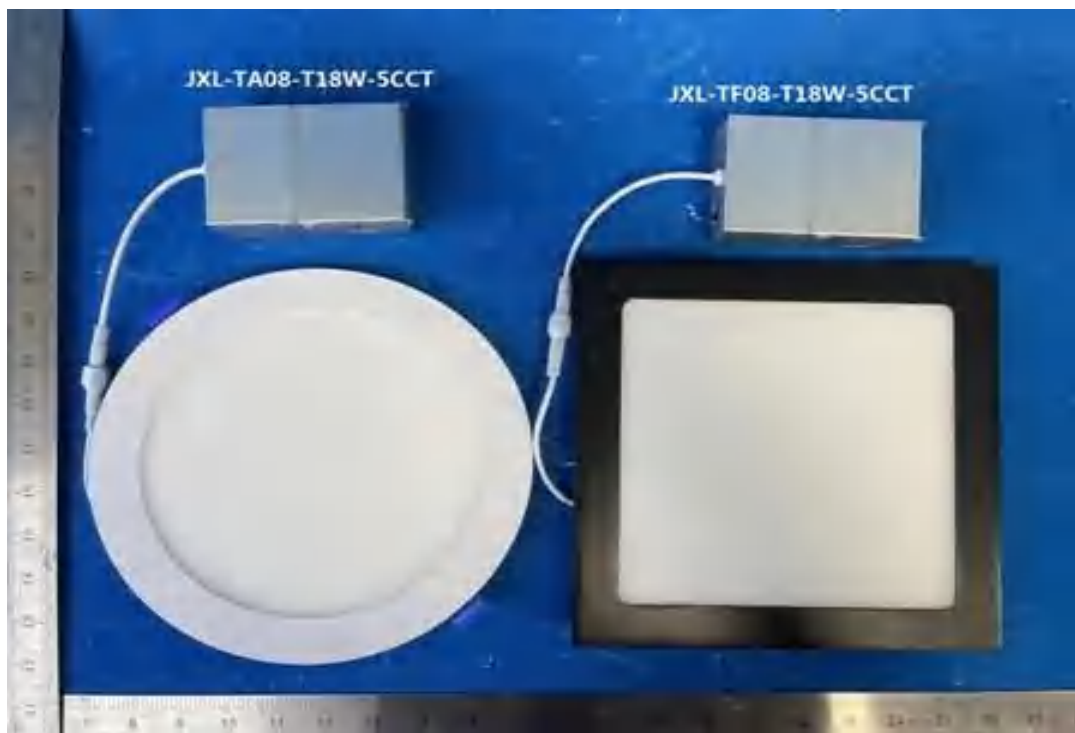


**3.0 Product Photographs**

**Photo 311** - Internal view of JXL-SMD04-G12W-5CCT

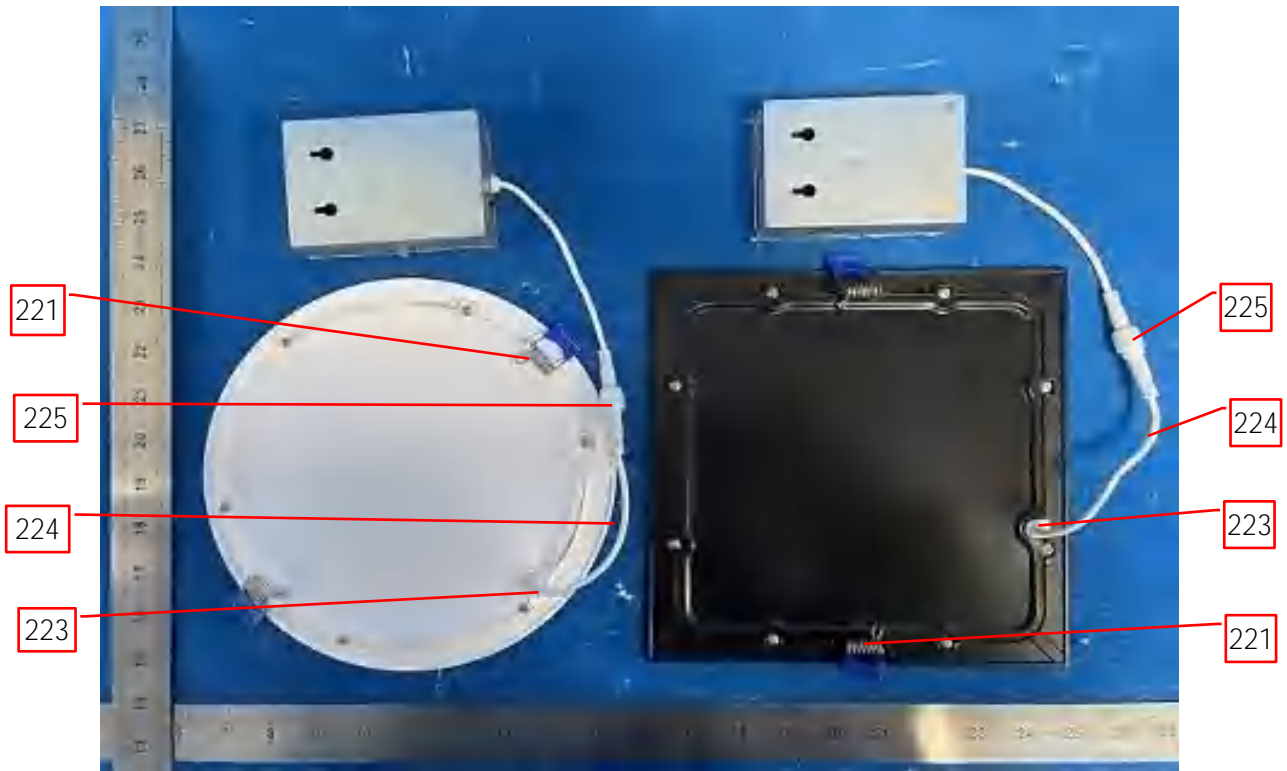


**Photo 312** - External view of JXL-TA08-T18W-5CCT and JXL-TF08-T18W-5CCT



**3.0 Product Photographs**

**Photo 313** - Back view of JXL-TA08-T18W-5CCT and JXL-TF08-T18W-5CCT

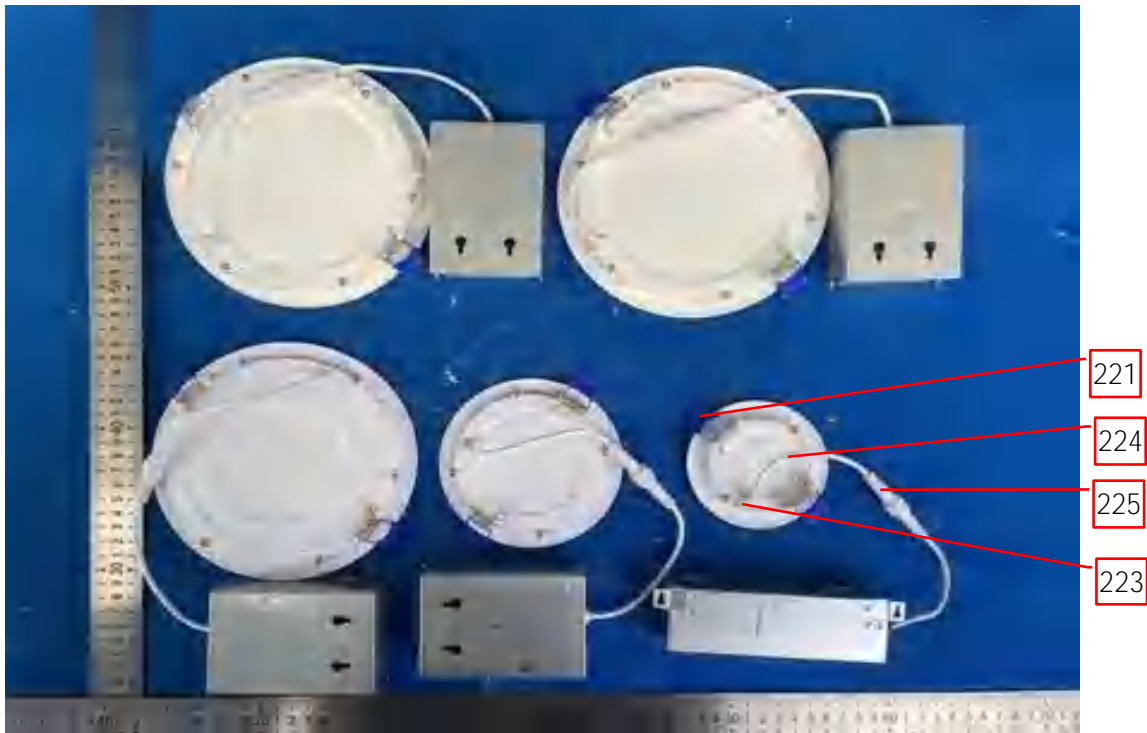


**Photo 314** - External view of JXL-CA06-T15W-5CCT, JXL-TZ06-T15W-5CCT, JXL-BK06-T12W-5CCT, JXL-TZ06-T12W-RGBCW, JXL-BK04-T10W-5CCT, JXL-TZ04-T10W-RGBCW and JXL-TZ03-T7W-5CCT

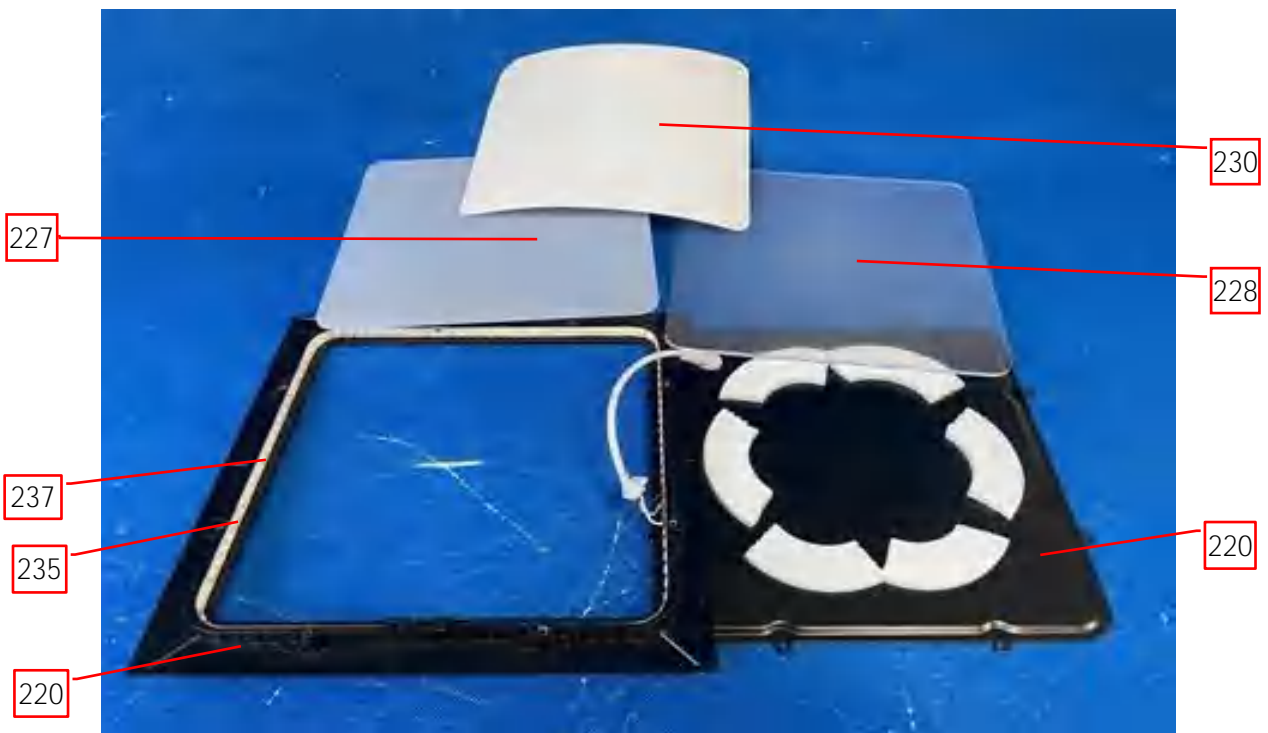


**3.0 Product Photographs**

**Photo 315** - Back view of JXL-CA06-T15W-5CCT, JXL-TZ06-T15W-5CCT, JXL-BK06-T12W-5CCT, JXL-TZ06-T12W-RGBCW, JXL-BK04-T10W-5CCT, JXL-TZ04-T10W-RGBCW and JXL-TZ03-T7W-5CCT

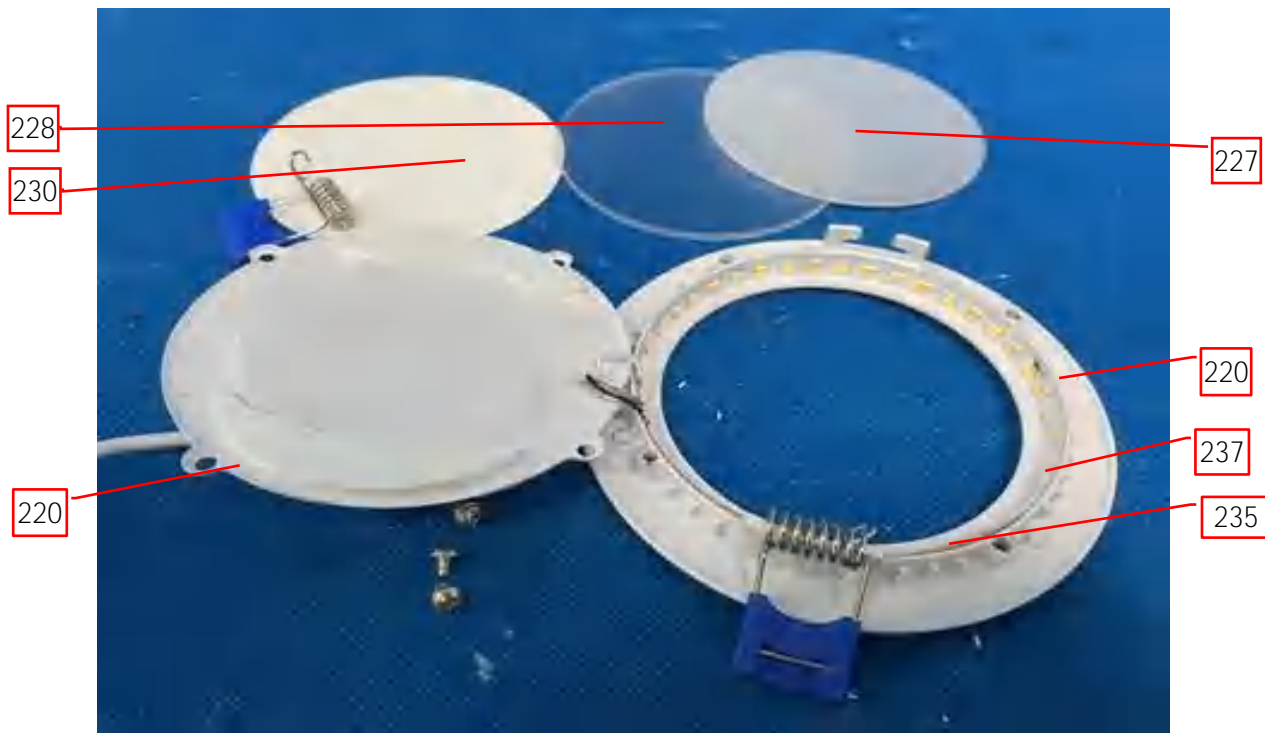


**Photo 316** - Internal view of JXL-TF08-T18W-5CCT

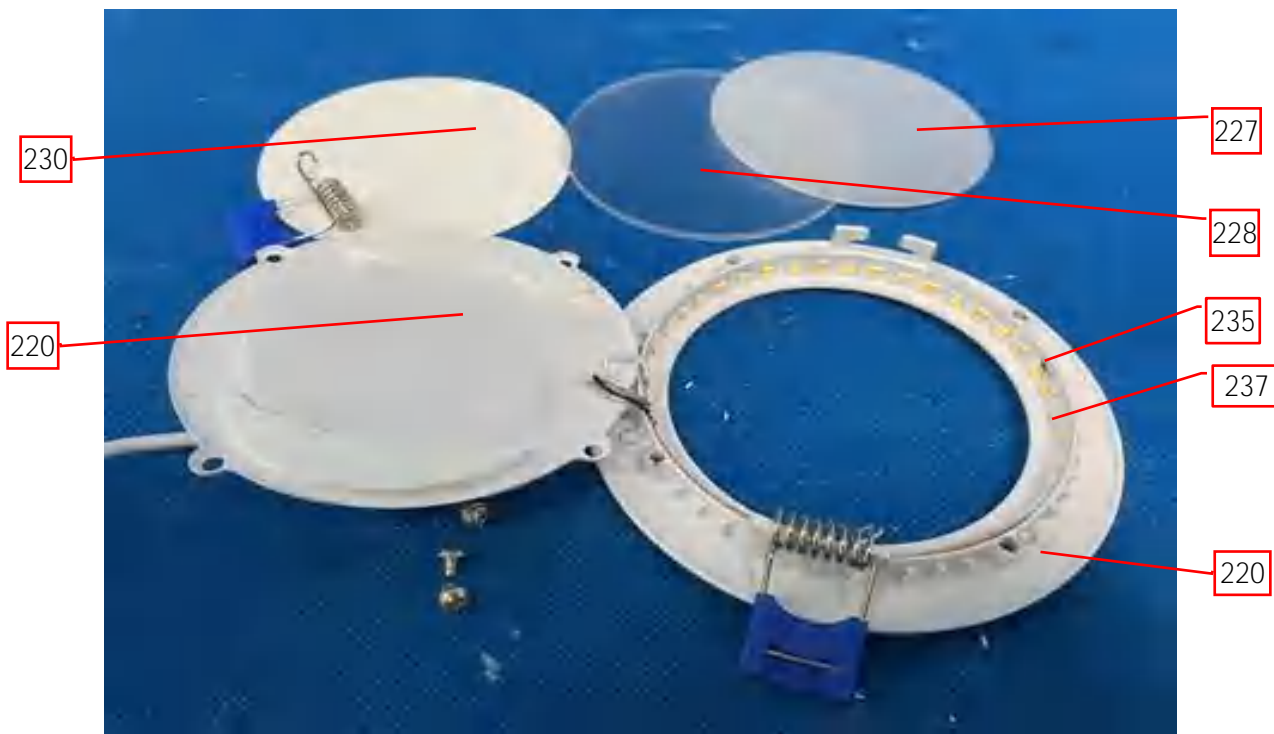


**3.0 Product Photographs**

**Photo 317** - Internal view of JXL-BK06-T12W-5CCT, JXL-BK04-T10W-5CCT and JXL-TZ03-T7W-5CCT

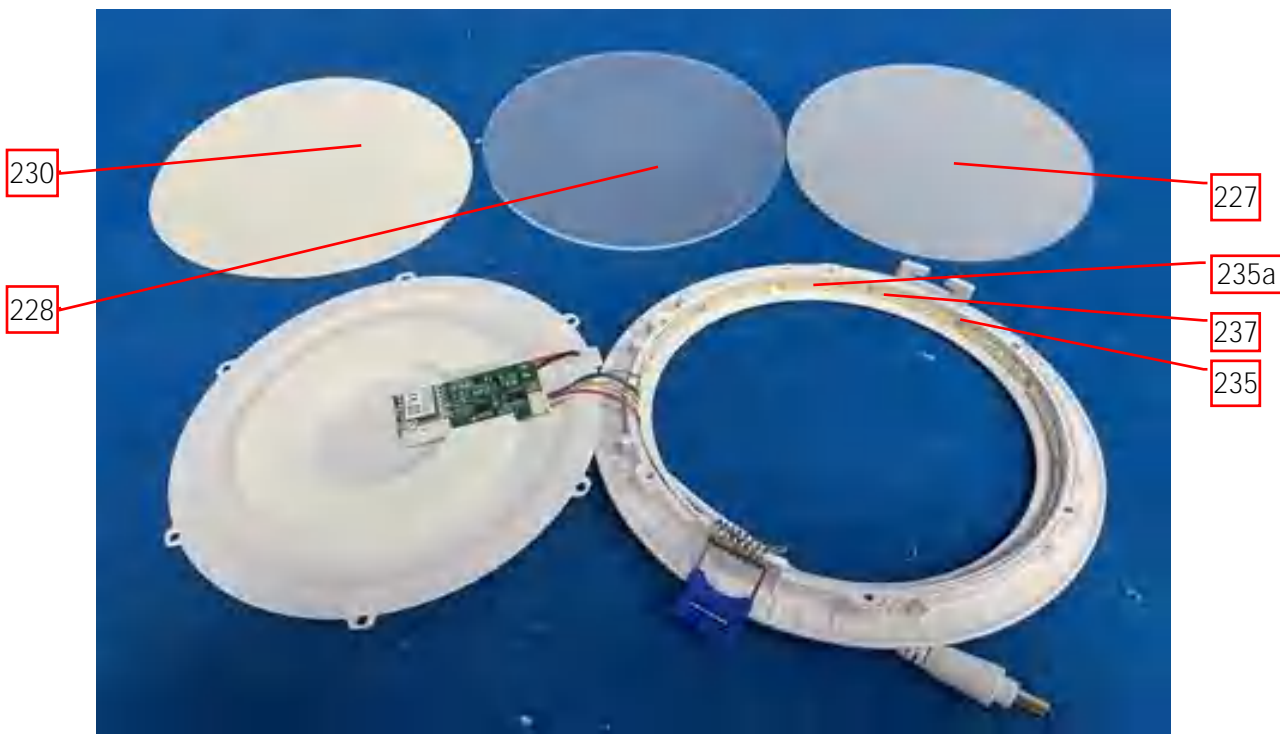


**Photo 318** - Internal view of JXL-TA08-T18W-5CCT, JXL-CA06-T15W-5CCT and JXL-TZ06-T15W-5CCT

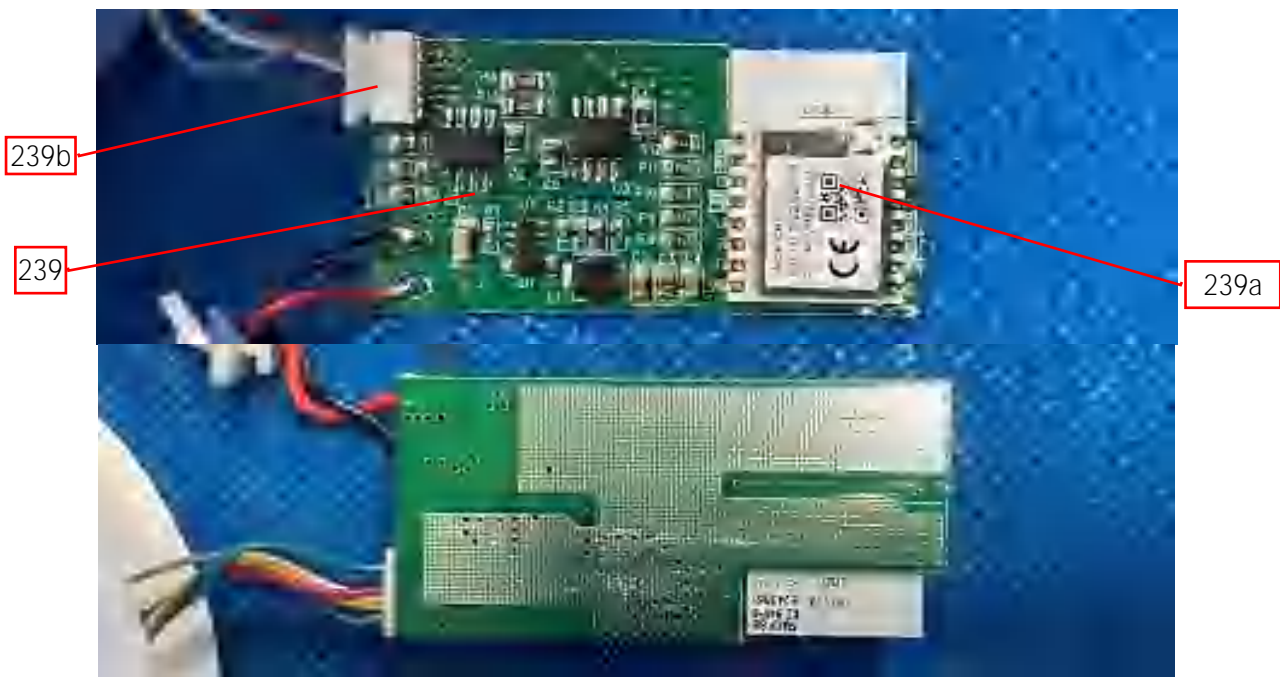


**3.0 Product Photographs**

**Photo 319** - Alternative internal view of JXL-TZ04-T10W-RGBCW and JXL-TZ06-T12W-RGBCW



**Photo 319a** - PCB Assembly View of Wifi module of JXL-TZ04-T10W-RGBCW and JXL-TZ06-T12W-RGBCW

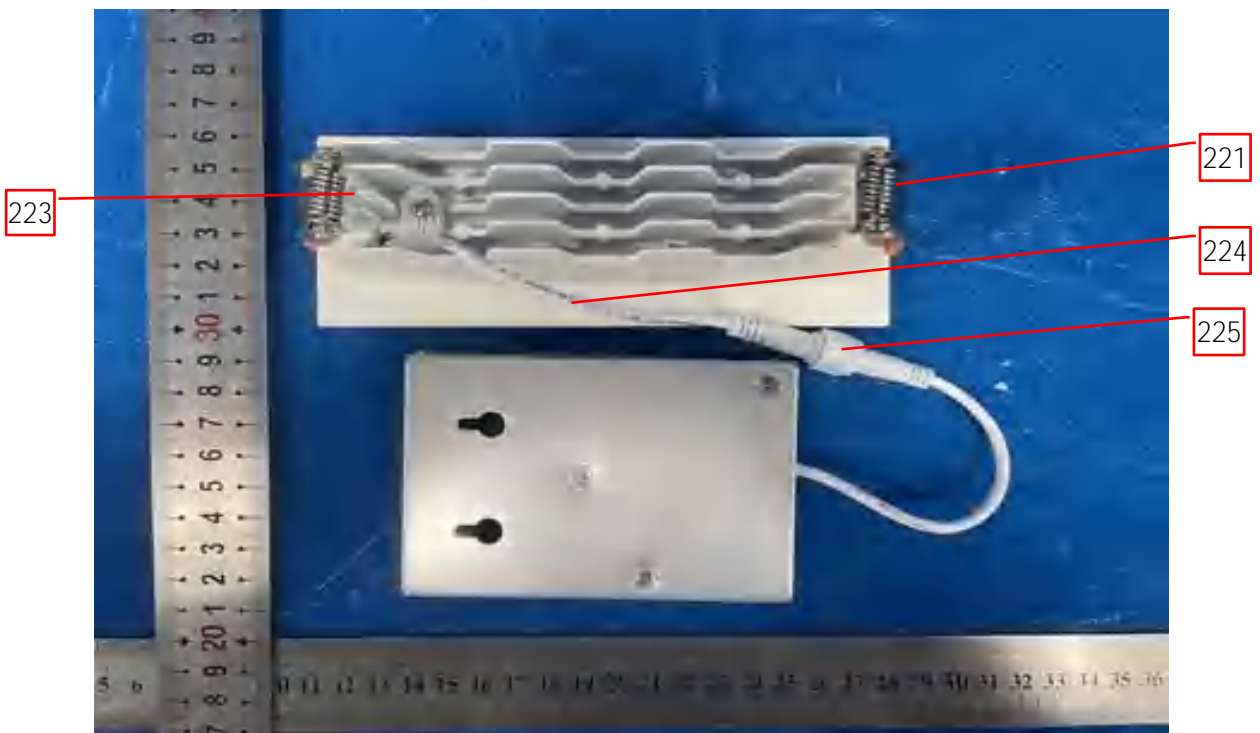


**3.0 Product Photographs**

**Photo 320** - External view of JXL-TXH05-T11W-5CCT



**Photo 321** - Back view of JXL-TXH05-T11W-5CCT

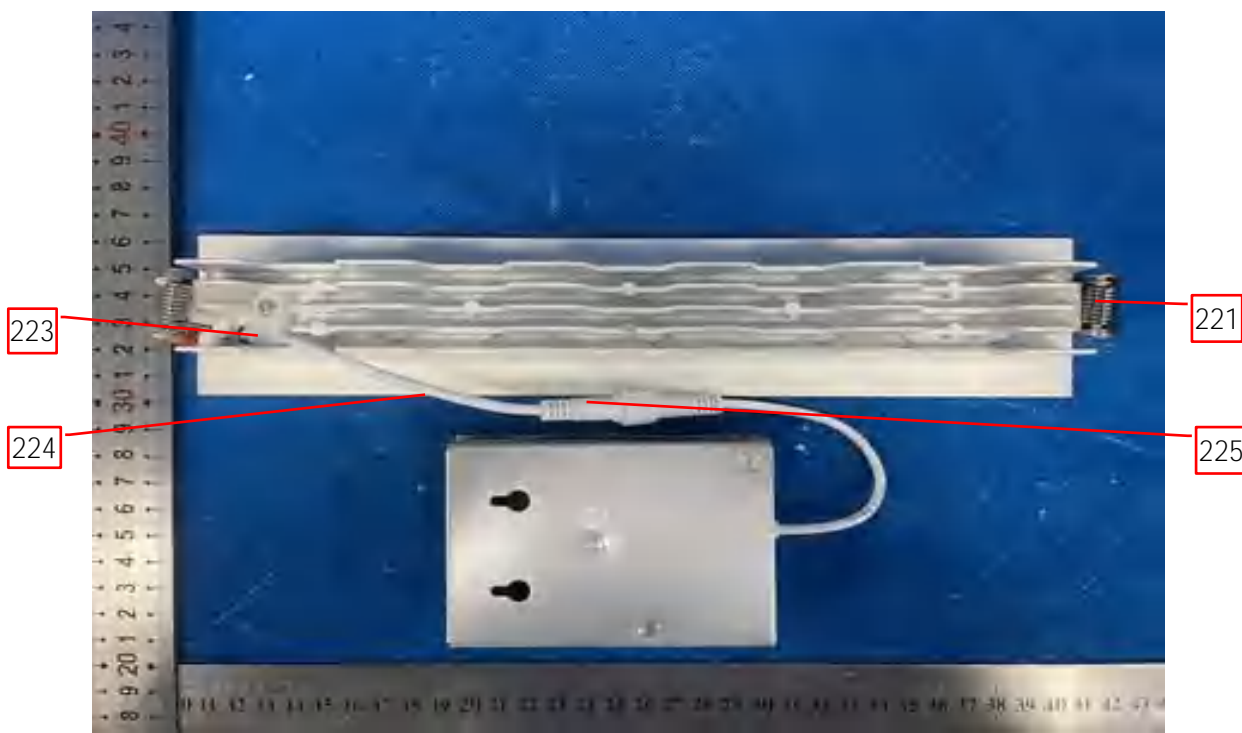


### 3.0 Product Photographs

**Photo 322** - External view of JXL-TXH10-T18W-5CCT

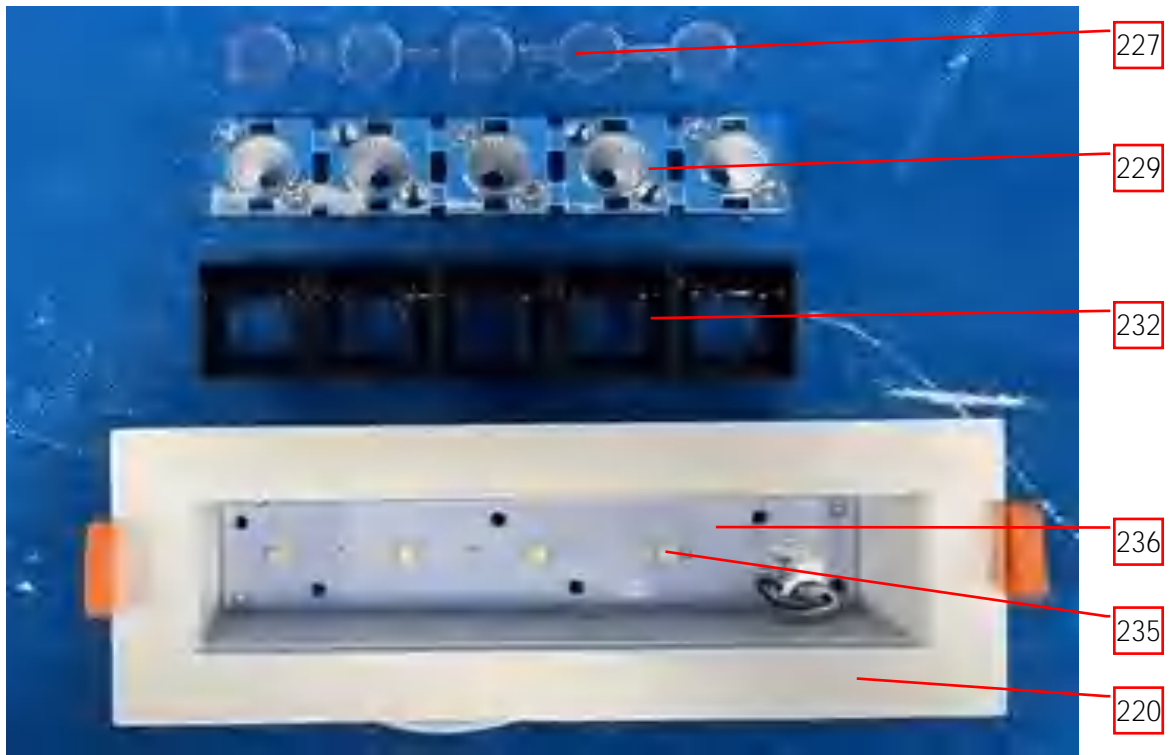


**Photo 323** - Back view of JXL-TXH10-T18W-5CCT

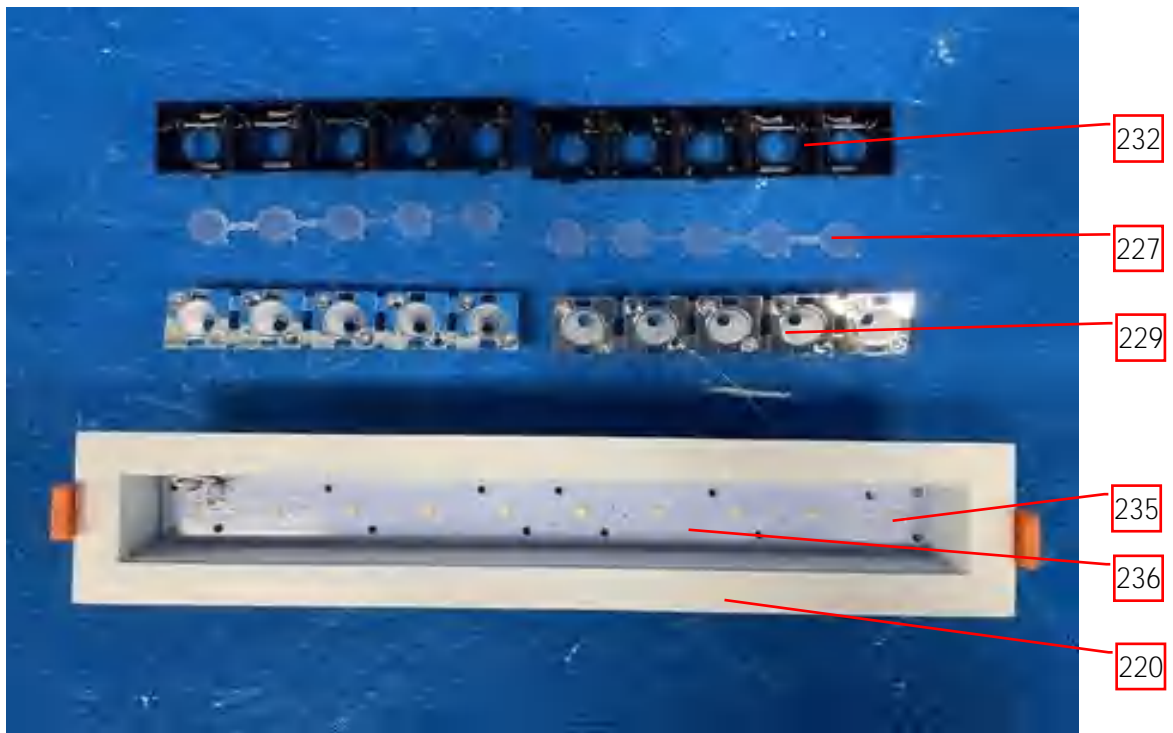


**3.0 Product Photographs**

**Photo 324** - Internal view of JXL-TXH05-T11W-5CCT



**Photo 325** - Internal view of JXL-TXH10-T18W-5CCT



### 3.0 Product Photographs

Photo 326 - External view of JXL-COB04-T10W-5CCT-XX

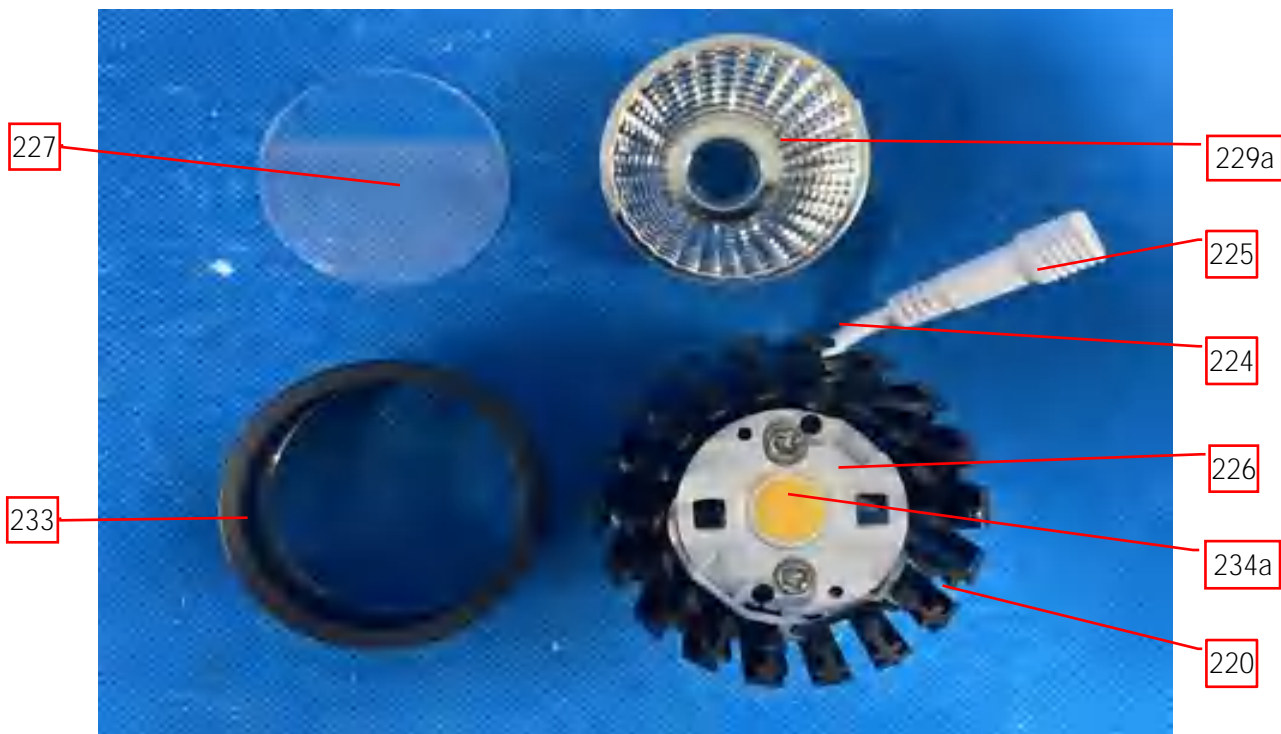


Photo 327 - Back view of JXL-COB04-T10W-5CCT-XX



**3.0 Product Photographs**

**Photo 328** - Internal view of JXL-COB04-T10W-5CCT-XX

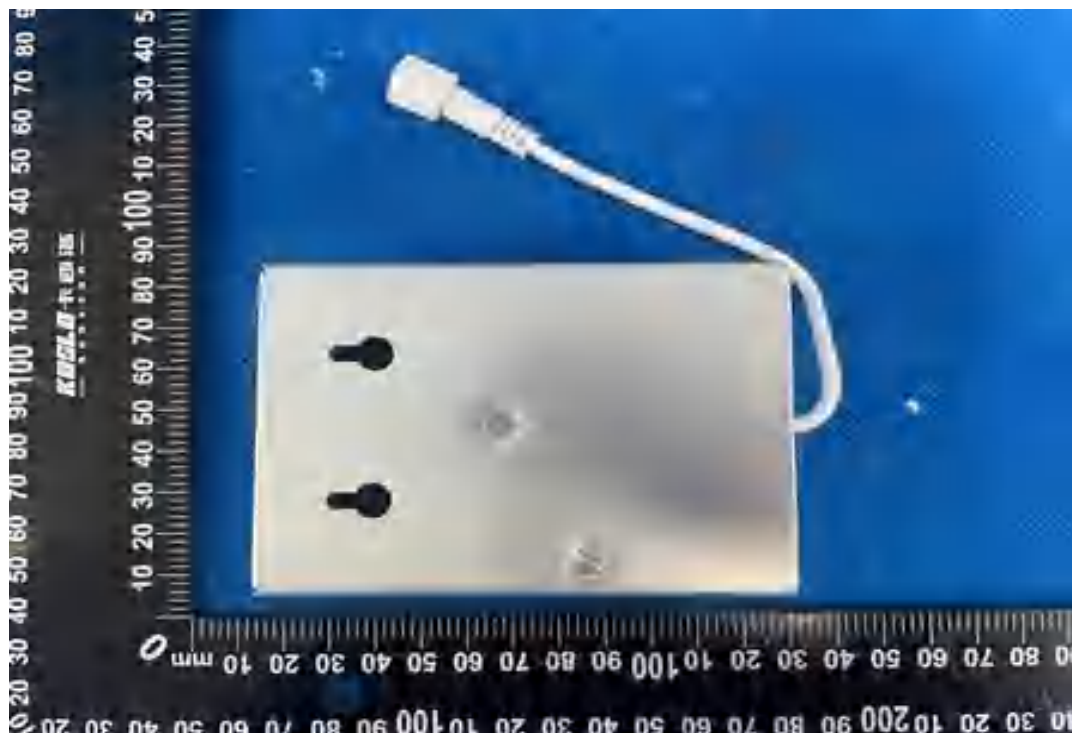


**Photo 329** - External Top View of LED Driver TR-062 and TR-054B

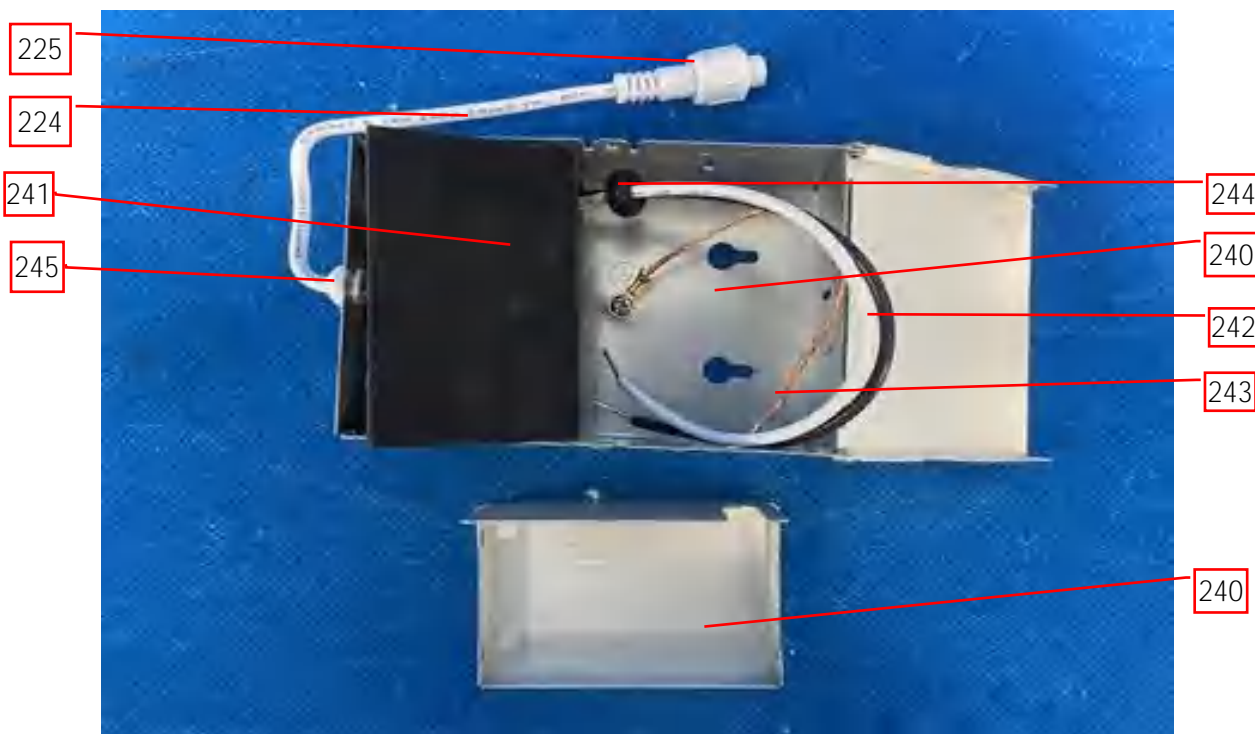


**3.0 Product Photographs**

**Photo 330** - External Bottom View of LED Driver TR-062 and TR-054B

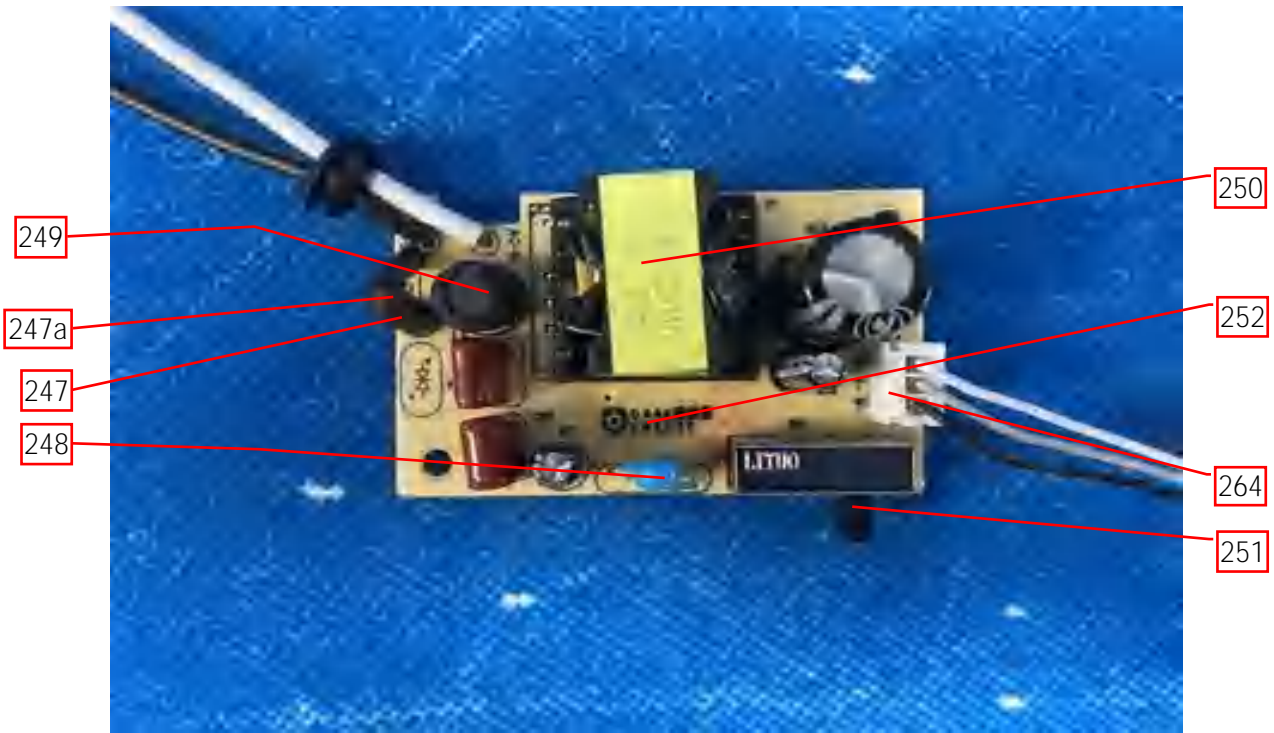


**Photo 331** - Internal View-1 of LED Driver TR-062 and TR-054B



**3.0 Product Photographs**

**Photo 332 - PCB Assembly Top View of LED Driver TR-062**



**Photo 333 - PCB Assembly Bottom View of LED Driver TR-062**

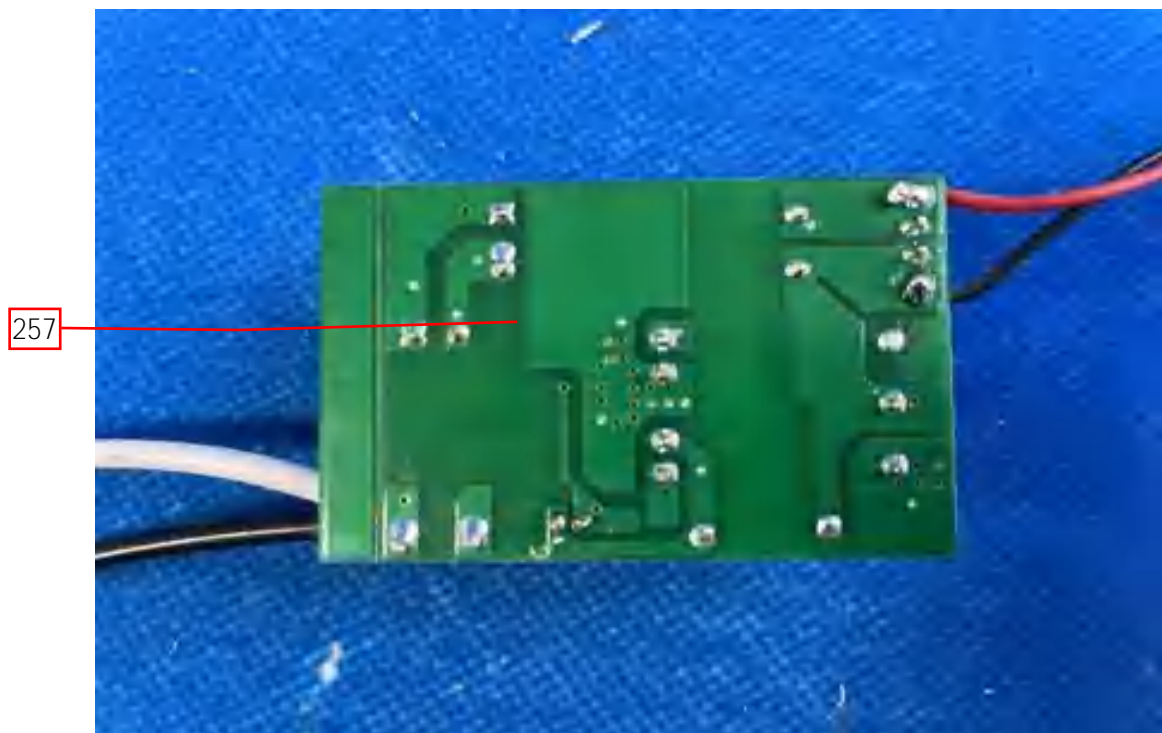


**3.0 Product Photographs**

**Photo 334 - PCB Assembly Top View of LED Driver TR-054B**



**Photo 335 - PCB Assembly Bottom View of LED Driver TR-054B**



**3.0 Product Photographs**

**Photo 336** - External Top View of LED Driver TR-071

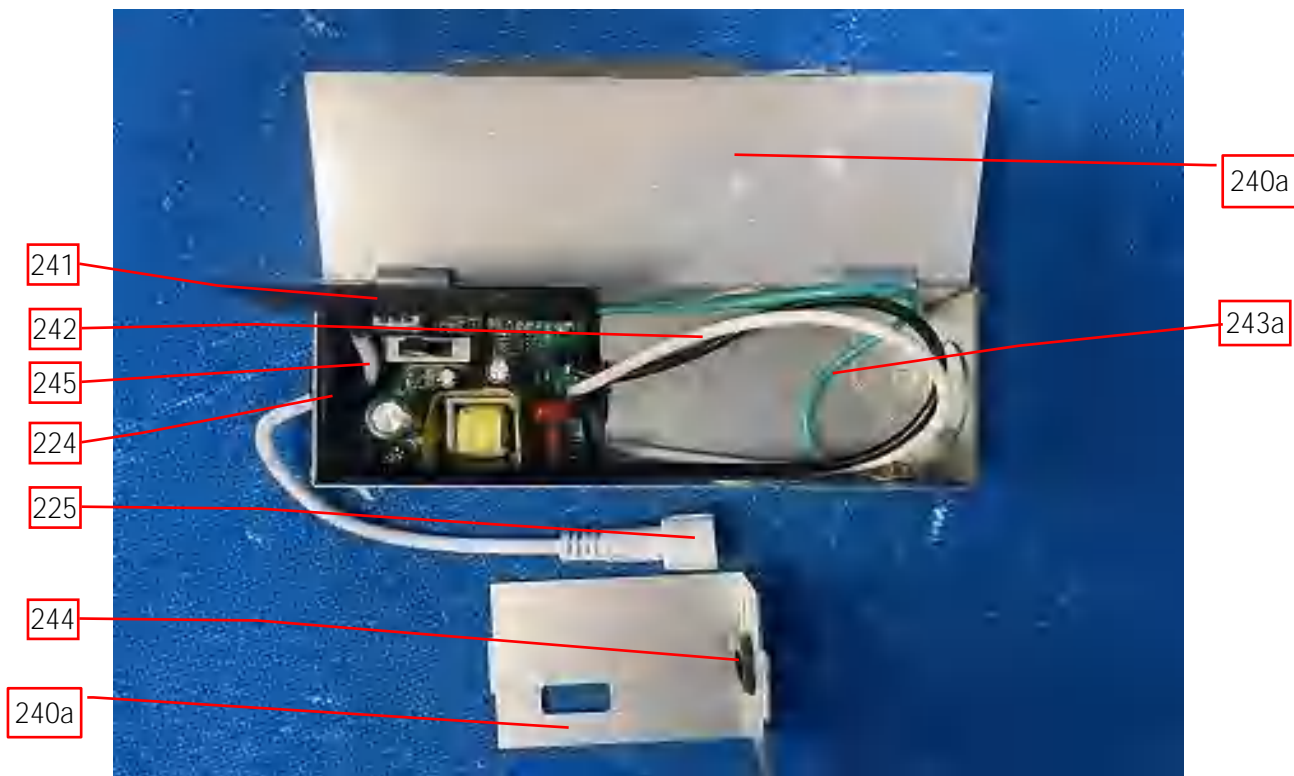


**Photo 337** - External Bottom View of LED Driver TR-071

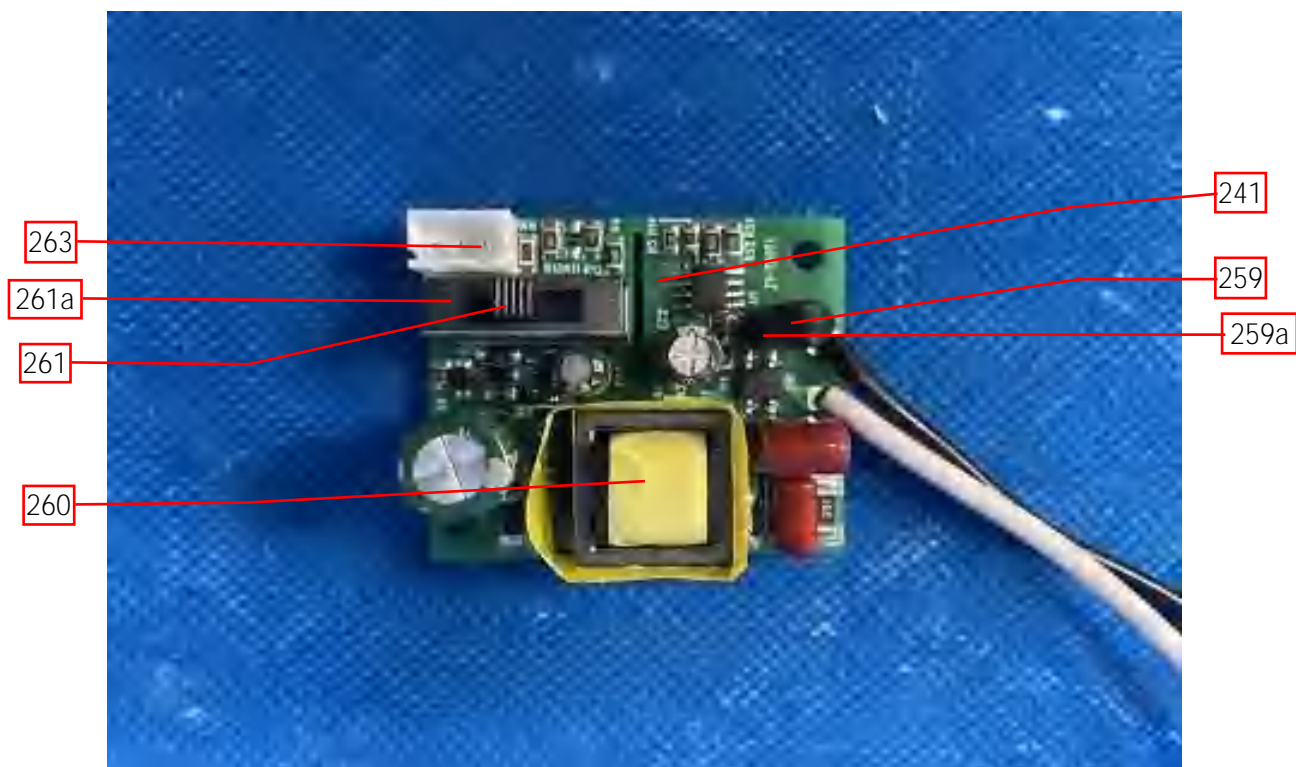


**3.0 Product Photographs**

**Photo 338** - Internal View-1 of LED Driver TR-071

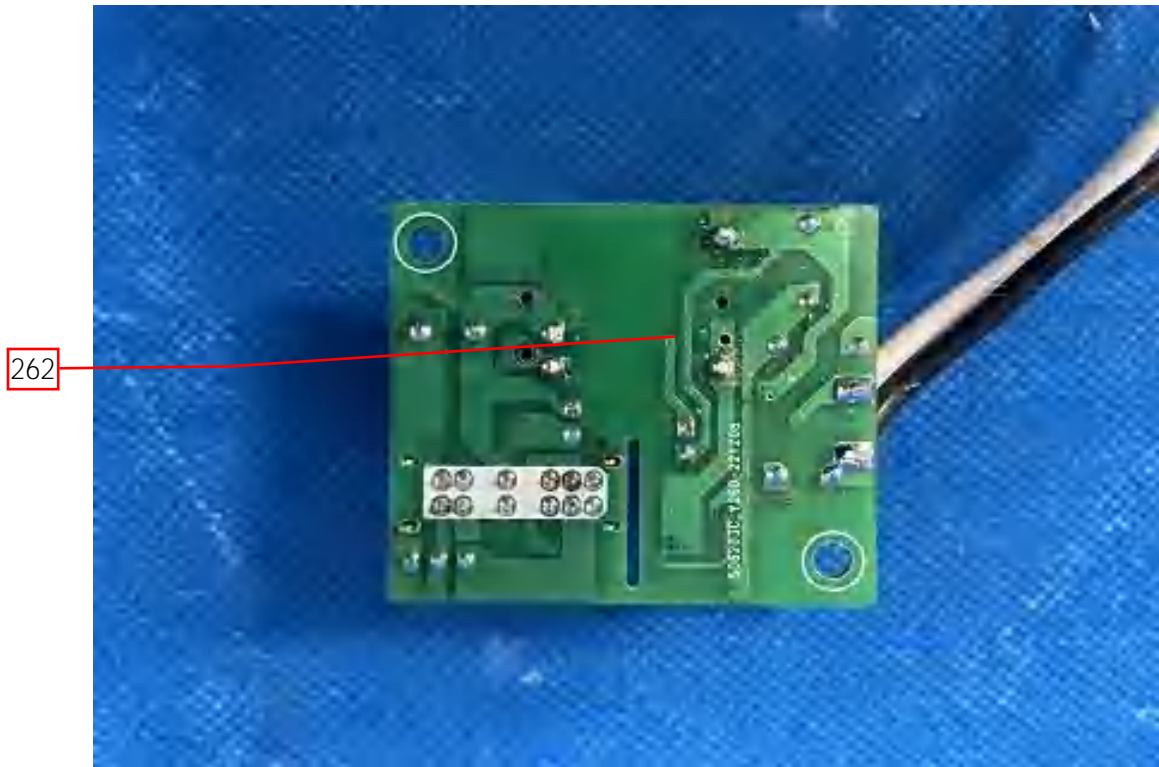


**Photo 339** - PCB Assembly Top View of LED Driver TR-071



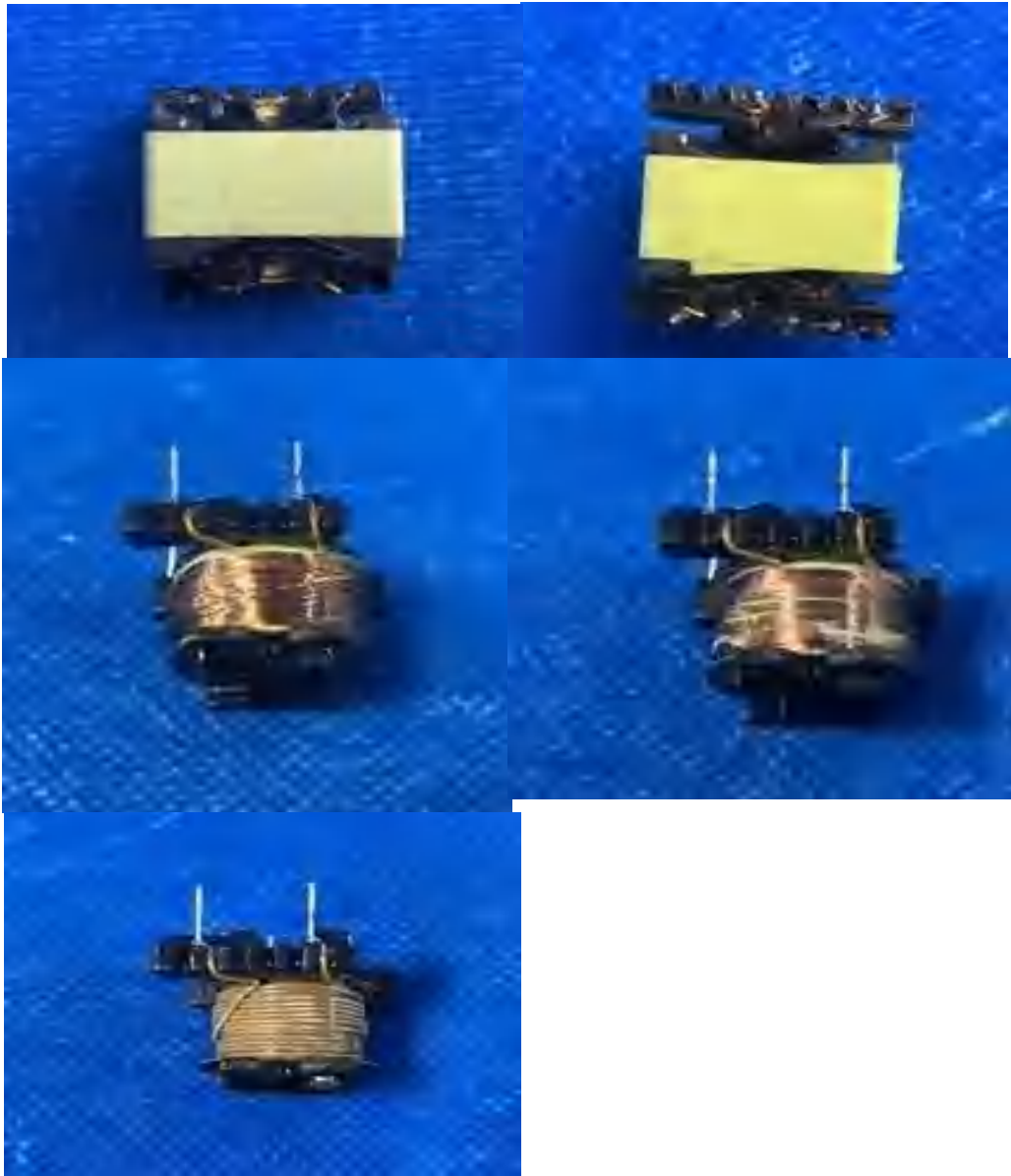
### 3.0 Product Photographs

Photo 340 - PCB Assembly Bottom View of LED Driver TR-071



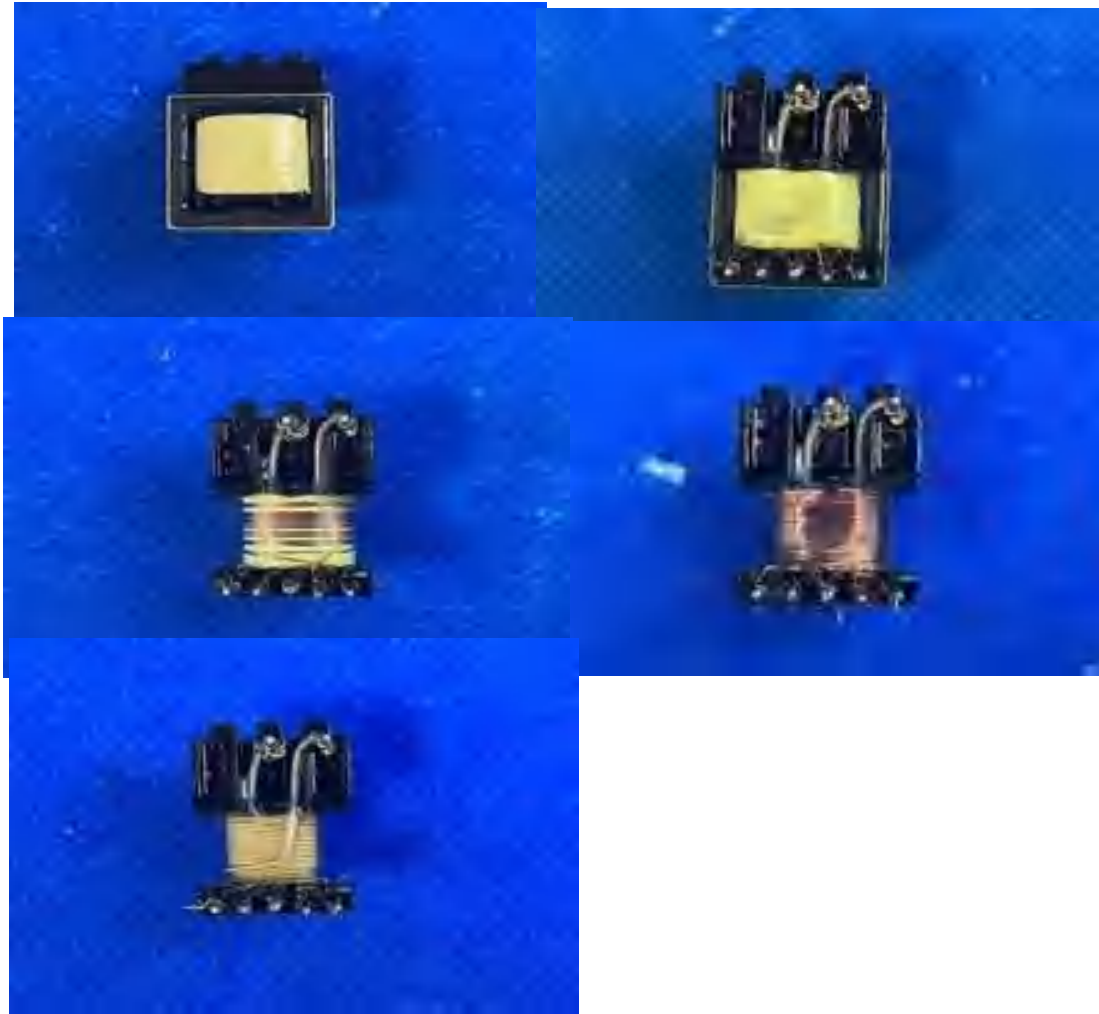
**3.0 Product Photographs**

**Photo 341** - Transformer (T1) construction of driver TR-062

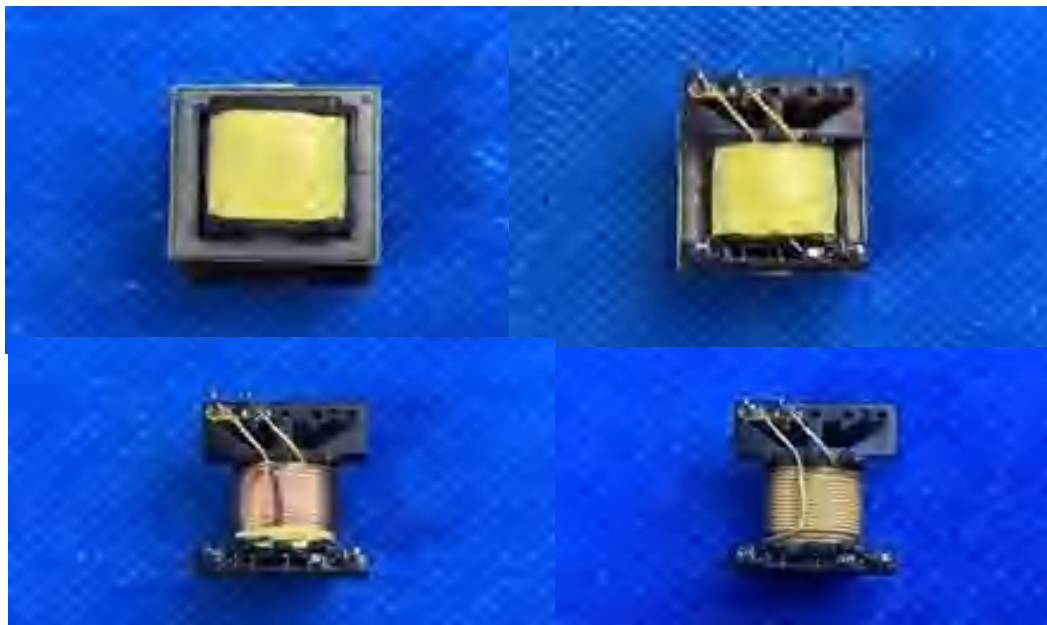


**3.0 Product Photographs**

**Photo 342** - Transformer (T1) construction of driver TR-054B



**Photo 343** - Transformer (T1) construction of driver TR-071



4.0 Critical Components						
Photo #	Item no. <sup>1</sup>	Name	Manufacturer/ trademark <sup>2</sup>	Type / model <sup>2</sup>	Technical data and securement means	Mark(s) of conformity <sup>3</sup>
22, 30, 103, 108	1	Trim	Various	Various	Sheet aluminum,1.0mm thick min,	NR
23, 31, 104, 109	1a	Back plate	Various	Various	Steel, 0.66mm thick min. Secured to trim by screws.	NR
23, 31, 104, 109	2	Clamp	Various	Various	Two provide.Steel.1.3mm thick. Secured to trim by snap fitting.	NR
15, 25, 105, 110	3	Mat	Various	Various	EPE, 80°C, 2.0mm thick min.Stick in reflector and used to separate reflector and back plate	UR
4, 9, 17, 27, 35, 63, 68, 93, 106, 111, 119, 121	4	LED	Various	Various	Vf = max. 3.3V, If = max. 150mA.	NR
17, 27, 106, 111, 119, 121	5	LED PCB	Various	Various	Flexible PCB. Rated min. V-1, 130°C, measured min 0.8 mm thick. CTI = 3 or better. Complied UL 796.	UR
11, 42, 46, 56, 59, 98, 102	6	Wiring compartment 1	Various	Various	Sheet steel, Dimensions of space for field wiring: 71mm x 39mm x 27mm.Provided three conduit opening with diameter 22.5mm, not using with through wiring. Min thickness: 0.66mm for junction box body and cover , secured on body by buckle.	NR
14, 24, 53, 288	6a	Wiring compartment 2	Various	Various	Sheet steel, Dimensions of space for field wiring: 85mm x 43mm x 32.1mm.Provided two conduit openings with diameter 22.5mm, not using with through wiring. Min thickness: 0.66mm for junction box body and cover , secured on body by buckle.	NR
25, 105, 110, 115, 120, 121	7	Diffuser	Various	Various	PC. HB, min. 80°C, 1.0mm thick	UR

4.0 Critical Components						
Photo #	Item no. <sup>1</sup>	Name	Manufacturer/ trademark <sup>2</sup>	Type / model <sup>2</sup>	Technical data and securement means	Mark(s) of conformity <sup>3</sup>
25, 34, 62, 105, 110, 121	8	Reflector	Various	Various	PBT, Measured 0.6 mm thick min., 125°C.	UR
25, 72, 77, 105, 110, 120	9	Lens	Various	Various	Glass, 2.11mm thick min.	NR
			E I DUPONT DE NEMOURS & CO INC	FR50(+)(f1)	PA66, 5VA, 1.5 mm thick min., 115°C, HWI=0, HAI=0, CTI=2	cURus
11, 16, 26, 42, 56, 59, 98, 107, 120, 122, 131	10	Cover of LED driver	Various	Various	Sheet steel, 0.66mm thick min, Secured to junction box by snap fitting.	NR
11, 16, 26, 40, 44, 55, 56, 58, 96, 96a, 103, 108, 173	11	Material for strain relief bushing	Various	Various	PE, 105°C, HB, 1.2mm thick min. Physically fitted to metal enclosure.	UR
11a, 26, 42, 46, 56, 59, 98, 107, 112, 114, 120, 122, 131	12	Barrier	Various	Various	PET, VTM-2, 105°C, HAI=min.2, HWI=min.2, CTI=min.4, min.5000V dielectric strength.0.18mm thick min. Fully cover the LED driver.	UR

4.0 Critical Components						
Photo #	Item no. <sup>1</sup>	Name	Manufacturer/ trademark <sup>2</sup>	Type / model <sup>2</sup>	Technical data and securement means	Mark(s) of conformity <sup>3</sup>
11, 26, 42, 46, 48, 59, 72, 74, 77, 79, 85, 98, 104, 107, 110, 113, 120, 122, 131	13	Bushing	Various	Various	PP, 120°C. 1.2mm thick min. Used to protect input and output wire of LED driver from sharp edge.	UR
22	14	Output wire 1	Various	CL2	2C x 22AWG. 300V. Min. 80°C. VW-1.	UL
44, 55, 58, 104, 109, 169, 173	15	Material for strain relief	Various	Various	PE, 105°C, 1.2mm thick.	UR
24, 42, 46, 56, 59, 98, 113, 120, 135	16	Input wire	Various	Various	Black and white, 2 x 18AWG, 600V, 105°C, VW-1. At least 150mm extending inside junction box.	cURus
24, 42, 46, 56, 59, 98, 113, 120, 135	17	Grounding wire	Various	Various	Green, 105°C 18AWG, Secured on back mounting plate with screw. Extended at least 150mm into outlet box.	UR
22, 25	18	Material of connector	Various	Various	PC. HB, min.75°C, 1.5mm thick	cURus
25, 34	19	Gasket	Various	Various	Silicone, 105°C. 1.2mm thick. Secured between diffuser and frame	UR
18, 28, 138, 140, 141	22a	Driver PWB	Various	Various	Single layer printed wiring board, V-0, 130°C, 1.2mm thick min. CTI = 3. Complied UL 796.	UR

4.0 Critical Components						
Photo #	Item no. <sup>1</sup>	Name	Manufacturer/ trademark <sup>2</sup>	Type / model <sup>2</sup>	Technical data and securement means	Mark(s) of conformity <sup>3</sup>
18, 19	23	LED Driver 1	Shenzhen goldsuno opto-electronic technology Co. Ltd.	TR017-A	Dimmable power supply. LVLE output. Input: 120V, 60Hz, 12W. Output: 42Vdc, 0.276A. Consisted of item 22a, 24 to 29	NR
18, 138, 140, 141	24	Fuse (F1)	Shenzhen Grate Electronic Technology Co. Ltd.	RXF-2W	2W, 22Ω, Rated 250Vac, in series with L line.	cURus
			Anhui Changsheng Electronic Technology Co. Ltd.	RXF-2W	2W, 22Ω, Rated 250Vac, in series with L line.	cURus
18, 138	25	Varistor (RV1)	Various	O7D561K	SPD type 5. Rated 320Vac, min. 125°C.	cURus
18	26	Y-capacitor (CY1, CY2)	Various	Various	Y1, 1000pF, min. 400Vac, 125°C min.	cURus
18	27	Inductors 1 (L1)	Various	Various	4.7mH. Refer to Illustration 11-12 for details. Consisted of the following components (Item 27a, 27b).	NR
18	27a	Magnetic wire of L1	Various	Various	Polyurethane, rated 130°C min. N1: 0.15mm in diameter, 415 turns.	UR
18	27b	Heat Shrinkable Tube of L1	Various	Various	600V, 125°C, VW-1.	cURus
18	28	Inductors 1 (LF2)	Various	Various	1.5mH. Refer to Illustration 17 for details. Consisted of the following components (Item 28a).	NR
18	28a	Magnetic wire of LF2	Various	2UEW	Polyurethane, rated 130°C min. N1: 0.4mm in diameter, 17 turns. N2: 0.4mm in diameter, 17 turns.	UR
18	29	Transformer 1 (T1)	Shenzhen Huaxinda Electronic Co., Ltd.	TR017	1200uH. Construction detailed, refer to Illustration 18-19.	See 5.0
28, 29	30	LED Driver 3	Shenzhen goldsuno opto-electronic technology Co. Ltd.	TR012	Dimmable power supply. LVLE output. Input: 120V, 60Hz, 12W. Output: 42Vdc, 0.27A. Consist of item 22a, 31 to 39.	NR

4.0 Critical Components						
Photo #	Item no. <sup>1</sup>	Name	Manufacturer/ trademark <sup>2</sup>	Type / model <sup>2</sup>	Technical data and securement means	Mark(s) of conformity <sup>3</sup>
28	31	Fuse (F1)	Shenzhen Grate Electronic Technology Co. Ltd.	RXF-2W	2W, 22Ω, Rated 250Vac, in series with L line.	cURus
			Anhui Changsheng Electronic Technology Co. Ltd.	RXF-2W	2W, 22Ω, Rated 250Vac, in series with L line.	cURus
28, 140, 141	32	Varistor (RV1)	Various	HEL07D471K	SPD type 5. Rated 300Vac, min. 105°C.	cURus
28, 138, 140, 141	33	Y-capacitor 2 (CY1)	Various	Various	Y1, 2.2nF, min. 400Vac, 125°C min.	cURus
28	34	Inductors 2 (L1)	Various	Various	1.2mH. Refer to Illustration 13-14 for details. Consisted of the following components (Item 34a, 34b).	NR
28	34a	Magnetic wire of L1	Various	Various	Polyurethane, rated 130°C min. N1: 0.15mm in diameter, 205 turns.	UR
28	34b	Heat Shrinkable Tube of L1	Various	Various	600V, 125°C, VW-1.	UR
28	35	Inductors (LF1)	Various	Various	50mH. Refer to Illustration 15 for details. Consisted of the following components (Item 35a-35c).	NR
28	35a	Magnetic wire of LF1	Various	Various	Polyurethane, rated 130°C min. N1: 0.15 mm in diameter, 120 turns.	UR
28	35b	insulation tape of LF1	Various	Various	Polyethylene terephthalate film insulating tapes, yellow, rated 130°C, 0.025 mm thick per layer. Min. 2 layers are provided as outer wrap.	UR
28	35c	Bobbin of LF1	Various	Various	PMC, V-0, 150°C, 0.45 mm thick min.	UR
28	36	Inductors 2 (LF2)	Various	Various	2mH. Refer to Illustration 16 for details. Consisted of the following components (Item 36a).	NR
28	36a	Magnetic wire of LF2	Various	2UEW	Polyurethane, rated 130°C min. N1: 0.4mm in diameter, 16 turns. N2: 0.4mm in diameter, 16 turns.	UR
28, 138	37	Switch (SK)	Various	Various	Consisted of the following components (Item 37a-37c).	UR
28, 138	37a	Material for switch (SK)	Various	Various	PC. HB, min.75°C, 1.0mm thick min.	UR
28, 138	37b	PCB of switch (SK)	Various	Various	Single layer printed wiring board, V-0, 130°C, 1.2mm thick min. CTI = 3. Complied UL 796.	UR

4.0 Critical Components						
Photo #	Item no. <sup>1</sup>	Name	Manufacturer/ trademark <sup>2</sup>	Type / model <sup>2</sup>	Technical data and securement means	Mark(s) of conformity <sup>3</sup>
28, 138	37c	Insulated tape of SK	Various	Various	Polyethylene terephthalate film insulating tapes, yellow, rated 130°C, 0.025 mm thick per layer. Min. 2 layers are provided as outer wrap and between windings.	UR
28, 33a, 138, 140, 141	38	Material for output connector	Various	Various	LCP, rated V-0, 130, min 2.5mm thick.	cURus
28	39	Transformer 2 (T1)	Shenzhen Huzxinda Electronic Co., Ltd.	TR012	1200uH. Construction detailed, refer to Illustration 20-21.	See 5.0
13, 23	43	Marking Label (Not shown)	Various	Various	Min. 90°C on metal surface. Complied with UL969.	UR
39, 43, 56, 59, 97, 97a, 101	44	Trim	Various	Various	Extruded aluminum. 1.0mm thick min.	NR
39, 43, 54, 57, 95, 95a, 103, 108, 130	45	Output wire	Various	Various	2 x 22AWG. 300V. Min. 105°C. VW-1.	UR
40a, 97, 116, 123	46	Clamping piece	Various	Various	Two provided. Steel. 0.66mm thick min. Secured between clamp frame.	NR
40a, 56, 59	47	Holder	Various	Various	PC or PMMA, HB, Min 120°C, 1.3mm thick min.	UR
40, 44, 55, 58, 83, 96, 96a	48	Heat sink	Various	Various	Extruded aluminum. 1.41mm thick min. Wire entrance is smooth and no sharp edge.	NR
40	49	Cable clip	Various	Various	PE, 120°C, 1.2mm thick.	UR
41, 45, 132	50	Reflector	Various	Various	PC or PMMA, HB, Min 120°C, 1.45mm thick min.	UR
41, 45	51	Lens mounting	Various	Various	Die-cast aluminum. 1.3mm thick.	NR
41, 132	52	Diffuser	Various	Various	Glass, 2.11mm thick min.	NR

4.0 Critical Components						
Photo #	Item no. <sup>1</sup>	Name	Manufacturer/ trademark <sup>2</sup>	Type / model <sup>2</sup>	Technical data and securement means	Mark(s) of conformity <sup>3</sup>
41, 45, 97, 130, 132	53	LED cover	Various	Various	PC. 94V-0, Min. 120°C. 1.6mm thick. Secured on heat sink by screws.	UR
41, 45, 97, 101, 130, 132	54	LED	Various	Various	COB. Vf= max. 39V, If=max. 860mA	cURus
45	55	Diffuser	Various	Various	PC, HB, 115°C, 1.0mm thick min.	UR
115, 123	59	Metal conduit	Various	Various	Sheet aluminum, 0.5mm thick min., 9.2mm in dia, secured by mechanical mean.	NR
97	60	Clamp frame	Various	Various	Extruded aluminum. 5mm thick.	NR
97	61	Lamp body	Various	Various	Extruded aluminum. 1.3mm thick min.	NR
97, 130	62	Diffuser	Various	Various	PC. HB. Min. 120°C. 8.3mm thick.	UR
97	63	Gasket	Various	Various	Silicone, 105°C. 1.2mm thick. Provided on Lens mounting.	UR
114, 135	65	Dimming wire	Various	Various	AWM, 2 x Min. 24AWG, 300V, 105°C, VW-1.	UR
130, 132	66	Reflector	Various	Various	Sheet aluminum. 0.8mm thick min.	UR
138	72	LED Driver 7	Shenzhen goldsuno opto-electronic technology Co. Ltd.	TR018-B	Dimmable power supply for 100-130V. LVLE output. Input: 100-277V, 50-60Hz, 25W. Output: 42Vdc, 0.58A. Consisted of item 22a, 24, 25, 28, 33, 38, 73-76	NR
138, 140, 141	73	Inductors (L1)	Various	Various	1.0mH. Refer to Illustration 33 for details. Consisted of the following components (Item 73a-73b).	NR
138, 140, 141	73a	Magnetic wire of L1	Various	Various	Polyurethane, rated 130°C min. N1: 0.27mm in diameter, 100 turns.	UR
138, 140, 141	73b	Heat Shrinkable Tube of L1	Various	Various	600V, 125°C, VW-1.	UR
138, 140, 141	74	Inductors (LF1)	Various	Various	20mH. Refer to Illustration 35 for details. Consisted of the following components (Item 74a-74b).	NR
138, 140, 141	74a	Magnetic wire of LF1	Various	Various	Polyurethane, rated 130°C min. N1: 0.27 mm in diameter, 120 turns.	UR
138, 140, 141	74b	Bobbin of LF1	Various	Various	PMC, V-0, 150°C, 0.45 mm thick min.	UR
138, 140, 141	75	Inductors (LF2)	Various	Various	1.2mH. Refer to Illustration 37 for details. Consisted of the following components (Item 75a-75b).	NR

4.0 Critical Components						
Photo #	Item no. <sup>1</sup>	Name	Manufacturer/ trademark <sup>2</sup>	Type / model <sup>2</sup>	Technical data and securement means	Mark(s) of conformity <sup>3</sup>
138, 140, 141	75a	Magnetic wire of LF2	Various	2UEW	Polyurethane, rated 130°C min. N1: 0.4mm in diameter, 16 turns.	UR
138, 140, 141	75b	Triple insulation wire of LF2	Various	TIW-B	Reinforced insulation, rated 130°C. N1: 0.4mm in diameter, 16 turns.	UR
138	76	Transformer (T1)	Shenzhen goldsuno opto-electronic technology Co. Ltd.	TR018-B	650uH. Construction detailed, refer to Illustration 40-41. For models JXL-TE06-T25W-CCT-xx, JXL-TE08-T25W-CCT-xx	See 5.0
140	77	LED Driver 8	Shenzhen goldsuno opto-electronic technology Co. Ltd.	DM001A	LVLE output. Input: 100-277V, 50-60Hz, 25W. Output: 42Vdc, 0.66A. Consisted of item 22a, 24, 32, 33, 38, 73-75b, 79-81	NR
141	78	LED Driver 9	Shenzhen goldsuno opto-electronic technology Co. Ltd.	DM001B	LVLE output. Input: 100-277V, 50-60Hz, 36W. Output: 42Vdc, 0.90A. Consisted of item 22a, 24, 32, 33, 38, 73-75b, 79-80b, 81a	NR
140, 141	79	X-capacitor ( CX1 )	Various	Various	X2, Min.305Vac, 110°C. 0.22uF	cURus
140, 141	80	Switch (SK)	Various	Various	Consisted of the following components (Item 80a-80b).	NR
140, 141	80a	Material for switch (SK)	Various	Various	PC. HB, min.75°C, 1.0mm thick min.	UR
140, 141	80b	PCB of switch (SK)	Various	Various	Single layer printed wiring board, V-0, 130°C, 1.2mm thick min. CTI = 3. Complied UL 796.	UR
140, 142	81	Transformer (T1)	Shenzhen goldsuno opto-electronic technology Co. Ltd.	DM001A	400uH. Construction detailed, refer to Illustration 44-45. For models JXL-TE06-E25/18/15W-UDD-xx, JXL-TE08-E25/18/15W-UDD-xx, JXL-COB04-E15W-UDD-xx, JXL-COB06-F25/18/15W-UDD-xx, JXL-COB08-F25/18/15W-UDD-xx, JXL-CA08-T25W-UDD-xx, JXL-CF08-T25W-UDD-xx	See 5.0
141, 142	81a	Transformer (T1)	Shenzhen goldsuno opto-electronic technology Co. Ltd.	DM001B	400uH. Construction detailed, refer to Illustration 46-47. For models JXL-COB08-F36W-UDD-xx, JXL-TE08-E36W-UDD-xx	See 5.0
39, 44, 55, 70, 75, 96, 96a, 103	82	Material of connector	Various	Various	PC. HB, min.105°C, 1.5mm thick	cURus

4.0 Critical Components						
Photo #	Item no. <sup>1</sup>	Name	Manufacturer/ trademark <sup>2</sup>	Type / model <sup>2</sup>	Technical data and securement means	Mark(s) of conformity <sup>3</sup>
115, 123	83	Metal enclosure	Various	Various	Extruded aluminum. 2.2mm thick min. The wire entrance are smooth and no sharp eddge	NR
145, 146b, 146e, 146h, 146k, 146n, 146q, 149, 150b, 150e, 150h, 150k, 150n, 150q, 153, 157, 160	84	Lamp housing	Various	Various	Aluminium, 1.1mm thick min.	NR

4.0 Critical Components						
Photo #	Item no. <sup>1</sup>	Name	Manufacturer/ trademark <sup>2</sup>	Type / model <sup>2</sup>	Technical data and securement means	Mark(s) of conformity <sup>3</sup>
145, 146b , 146e , 146h , 146k , 146n , 146q , 149, 150b , 150e , 150h , 150k , 150n , 150q , 153, 157, 160	84a	Lamp housing	Various	Various	Steel, 1.1mm thick min.	NR
169, 170, 173, 177, 185	84b	Lamp housing	Various	Various	Aluminium, 1.1mm thick min.	NR
169, 170, 173, 177, 185	84c	Lamp housing	Various	Various	Steel, 1.1mm thick min.	NR
158	84d	Gasket	Various	Various	Silicone rubber, min, 1.0mm thick.	NR

4.0 Critical Components						
Photo #	Item no. <sup>1</sup>	Name	Manufacturer/ trademark <sup>2</sup>	Type / model <sup>2</sup>	Technical data and securement means	Mark(s) of conformity <sup>3</sup>
145, 146b, 146e, 146h, 146k, 146n, 146q, 149, 150b, 150e, 150h, 150k, 150n, 150q, 153, 157, 160	85	Mounting Clamp	Various	Various	Two provide. Steel.1.0mm thick. May be provided with metal or plastic housing. Secured to housing by screws or snap fitting.	NR
169, 173, 177, 185	85a	Mounting Clamp	Various	Various	Two provide. Steel.1.0mm thick. May be provided with metal or plastic housing. Secured to housing by screws or snap fitting.	NR

4.0 Critical Components						
Photo #	Item no. <sup>1</sup>	Name	Manufacturer/ trademark <sup>2</sup>	Type / model <sup>2</sup>	Technical data and securement means	Mark(s) of conformity <sup>3</sup>
145, 146b, 146e, 146k, 146h, 146n, 146q, 149, 150b, 150e, 150h, 150k, 150n, 150q, 176c, 177, 185	86	Bushing	Various	Various	Plastic, non-rubber type, rated min. HB, 80°C, 1.0mm thick.	cURus

4.0 Critical Components						
Photo #	Item no. <sup>1</sup>	Name	Manufacturer/ trademark <sup>2</sup>	Type / model <sup>2</sup>	Technical data and securement means	Mark(s) of conformity <sup>3</sup>
145, 146b , 146e , 146k , 146h , 146n , 146q , 149, 150b , 150e , 150h , 150k , 150n , 150q , 153, 157, 162, 162a , 169, 170, 173, 177, 185, 193, 196a , 199	87	Output wire	Various	CL2	Rated min. 24AWG, 300V, 105°C, VW-1.	UL
			Various	Various	AWM, rated min. 24AWG, 300V, 105°C, VW-1.	UR

4.0 Critical Components						
Photo #	Item no. <sup>1</sup>	Name	Manufacturer/ trademark <sup>2</sup>	Type / model <sup>2</sup>	Technical data and securement means	Mark(s) of conformity <sup>3</sup>
145, 146b , 146e , 146h , 146k , 146n , 146q , 149, 150b , 150e , 150h , 150k , 150n , 150q , 153, 157, 169, 173, 177, 185, 193, 196a , 199	88	Material for output connector	Various	Various	LCP, rated min. HB, 80°C, min 2.5mm thick.	cURus

4.0 Critical Components						
Photo #	Item no. <sup>1</sup>	Name	Manufacturer/ trademark <sup>2</sup>	Type / model <sup>2</sup>	Technical data and securement means	Mark(s) of conformity <sup>3</sup>
146, 146c, , 146f, 146i, 146l, 146o, , 146r, , 150, 150c, , 150f, 150i, 150l, 150o, , 150r, , 158, 178, 186	89	Lens	Various	Various	PC, rated min. HB, 115°C, 1.5mm thick min.	cURus

4.0 Critical Components						
Photo #	Item no. <sup>1</sup>	Name	Manufacturer/ trademark <sup>2</sup>	Type / model <sup>2</sup>	Technical data and securement means	Mark(s) of conformity <sup>3</sup>
146, 146c , 146f, 146i, 146l, 146o , 146r , 150, 150c , 150f, 150i, 150l, 150o , 150r , 154, 158, 174,	90	LED frame	Various	Various	PC, rated min. HB, 115°C, 1.0mm thick	cURus
154, 162, 162a , 170, 174, 178, 186	91	Diffuser	Various	Various	PC or PS. HB, min. 80°C, 1.0mm thick.	UR

4.0 Critical Components						
Photo #	Item no. <sup>1</sup>	Name	Manufacturer/ trademark <sup>2</sup>	Type / model <sup>2</sup>	Technical data and securement means	Mark(s) of conformity <sup>3</sup>
146, 146c , 146f, 146i, 146l, 146o , 146r , 150, 150c , 150f, 150i, 150l, 150o , 150r , 158, 162, 162a , 170, 174, 178	92	Reflector	Various	Various	PC or PBT, rated min. 125°C, 1.0mm thick.	UR

4.0 Critical Components						
Photo #	Item no. <sup>1</sup>	Name	Manufacturer/ trademark <sup>2</sup>	Type / model <sup>2</sup>	Technical data and securement means	Mark(s) of conformity <sup>3</sup>
146, 146c, 146f, 146i, 146l, 146o, 146r, 150, 150c, 150f, 150i, 150l, 150o, 150r, 158	93	COB	Various	Various	Rated max. If:300mA, Vf:36-40V, for model see Illustration 50 item 2.	NR
			Various	Various	Rated max.If:300mA, Vf:45-48V ,for model see Illustration 50 item 3.	NR
			Various	Various	Rated max. If:300-690mA, Vf:42-48V ,for model see Illustration 50 item 4.	NR
			Various	Various	Rated max. If:300-690mA, Vf:27-29V ,for model see Illustration 50 item 7.	NR
			Various	Various	Rated max. If:300-690mA, Vf:36-42V ,for model see Illustration 50 item 8.	NR
			Various	Various	Rated max. If:300-690mA, Vf:30-36V,for model see Illustration 50 item 9.	NR
154, 162, 162a, 170, 174, 178, 186	94	LED	Various	Various	Rated max. If:150mA,Vf:3.1-3.3V,for model see Illustration 50 item 5.	NR
			Various	Various	Rated max. If:240mA,Vf:5.8-6.2V,for model see Illustration 50 item 6.	
154, 162, 162a, 170, 174, 178, 186	95	LED PCB	Various	Various	Single layer metal base, rated min. V-0, 130°C, 1.0mm thick.	UR
202	98	LED Driver-12	Shenzhen goldsuno opto-electronic technology Co. Ltd.	TR-012B	LVLE output. Input: 120V, 60Hz, 12W. Output: 27-42Vdc, 0.27A.for models see Illustration 51 item 7. Consisted of item 98a to 98d, 115 to 117a.	NR
202	98a	Fuse (F1)	SHENZHEN GREAT ELECTRONICS CO LTD	RXF-2W	2W, 22Ω.	cURus
			SHENZHEN YUZHOUXIN ELECTRONIC CO LTD	XRF-1W	1W, 22Ω.	cURus

4.0 Critical Components						
Photo #	Item no. <sup>1</sup>	Name	Manufacturer/ trademark <sup>2</sup>	Type / model <sup>2</sup>	Technical data and securement means	Mark(s) of conformity <sup>3</sup>
202	98b	Varistor (VR1)	Various	07D471K	SPD type 5. Rated 300Vac, min. 125°C.	cURus
202	98c	Y-capacitor (CY1)	Various	Various	Y1, 1000pF, min. 400Vac, 125°C min.	cURus
202	98d	Transformer (T1)	SHENZHEN JINHUADA ELECTRONICS CO., LTD.	TR-012B	1.35mH.Construction detailed, refer to Illustration 60 and 61	See 5.0
203	99	LED Driver-13	Shenzhen goldsuno opto-electronic technology Co. Ltd.	TR-019	LVLE output. Input: 120V, 60Hz, 12W. Output: 24-42Vdc, 0.28A.for models see Illustration 51 item 11.Consisted of item 99a to 99d, 115.	NR
203	99a	Fuse (F1)	SHENZHEN GREAT ELECTRONICS CO LTD	RXF-2W	2W, 22Ω.	cURus
			SHENZHEN YUZHOUXIN ELECTRONIC CO LTD	XRF-1W	1W, 22Ω.	cURus
203	99b	Varistor (VR1)	Various	07D471K	SPD type 5. Rated 300Vac, min. 125°C.	cURus
203	99c	Y-capacitor (CY1)	Various	Various	Y1, 1000pF, min. 400Vac, 125°C min.	cURus
203, 220, 220a	99d	Transformer (T1)	SHENZHEN JINHUADA ELECTRONICS CO., LTD.	TR-019	1.35mH.Construction detailed, refer to Illustration 60 and 61	See 5.0
209, 288	100	LED Driver-14	Shenzhen goldsuno opto-electronic technology Co. Ltd.	TR-018D	LVLE output. Input: 100-277V, 60Hz, 18W. Output: 42-58Vdc, 0.28A.for models see Illustration 51 item 4.Consisted of item 100a to 100d, 115.	NR
209	100 a	Fuse (FR1)	SHENZHEN GREAT ELECTRONICS CO LTD	RXF-2W	2W, 22Ω	cURus
			SHENZHEN YUZHOUXIN ELECTRONIC CO LTD	XRF-1W	1W, 22Ω.	cURus
209	100 b	Varistor (RV1)	Various	07D561K	SPD type 5. Rated 300Vac, min. 125°C.	cURus
209	100 c	Y-capacitor (CY1)	Various	Various	Y1, 2200pF, min. 400Vac, 125°C min.	cURus
209	100 d	Transformer (T1)	SHENZHEN JINHUADA ELECTRONICS CO., LTD.	TR018D	0.75mH.Construction detailed, refer to Illustration 70 and 71.	See 5.0
209	100 e	Inductor (L1)	Various	Various	1.0mH, Consisted of item 100e1 to 100e2.	NR

4.0 Critical Components						
Photo #	Item no. <sup>1</sup>	Name	Manufacturer/ trademark <sup>2</sup>	Type / model <sup>2</sup>	Technical data and securement means	Mark(s) of conformity <sup>3</sup>
209	100 e1	Magnetic wire of L1	Various	Various	Polyurethane, rated 130°C min. N1: 0.27mm in diameter, 100 turns.	UR
209	100 e2	Heat Shrinkable Tube of L1	Various	Various	600V, 125°C, VW-1.	UR
205	101	LED Driver-15	Shenzhen goldsuno opto-electronic technology Co. Ltd.	TR-023A	LVLE output. Input: 100-277V, 60Hz, 12W. Output: 27-42Vdc, 0.29A.for models see Illustration 51 item 3.Consisted of item 101a to 101d, 115 and 116.	NR
205	101 a	Fuse (FR1)	SHENZHEN GREAT ELECTRONICS CO LTD	RXF-2W	2W, 22Ω.	cURus
			SHENZHEN YUZHOUXIN ELECTRONIC CO LTD	XRF-1W	1W, 22Ω.	cURus
205	101 b	Varistor (RV1)	Various	07D561K	SPD type 5. Rated 300Vac, min. 125°C.	cURus
205	101 c	Y-capacitor (CY1)	Various	Various	Y1, 1000pF, min. 400Vac, 125°C min.	cURus
205	101 d	Transformer (T1)	SHENZHEN JINHUADA ELECTRONICS CO., LTD.	TR023A	1.10mH.Construction detailed, refer to Illustration 66 and 67.	See 5.0
204	104	LED Driver-18	Shenzhen goldsuno opto-electronic technology Co. Ltd.	TR-030	LVLE output. Input: 120V, 60Hz, 18W. Output: 42-58Vdc, 0.30A.for models see Illustration 51 item 10.Consisted of item 104a to 104d, 115 to 117a.	NR
204	104 a	Fuse (F1)	SHENZHEN GREAT ELECTRONICS CO LTD	RXF-2W	2W, 2.2Ω.	cURus
			SHENZHEN YUZHOUXIN ELECTRONIC CO LTD	XRF-1W	1W, 2.2Ω.	cURus
204	104 b	Varistor (RV1)	Various	07D471K	SPD type 5. Rated 320Vac, min. 125°C.	cURus
204	104 c	Y-capacitor (CY1)	Various	Various	Y1, 1000pF, min. 400Vac, 125°C min.	cURus
204	104 d	Transformer (T1)	SHENZHEN JINHUADA ELECTRONICS CO., LTD.	TR030	0.75-0.8mH,Construction detailed, refer to Illustration 74 and 75.	See 5.0

4.0 Critical Components						
Photo #	Item no. <sup>1</sup>	Name	Manufacturer/ trademark <sup>2</sup>	Type / model <sup>2</sup>	Technical data and securement means	Mark(s) of conformity <sup>3</sup>
207	105	LED Driver-19	Shenzhen goldsuno opto-electronic technology Co. Ltd.	TR-031A	LVLE output. Input: 100-277V, 60Hz, 18W. Output: 27-39Vdc, 0.50A.for models see Illustration 51 item 5.Consisted of item 106a to 106h except 106e, 114, 115 and 116.	NR
207	106 a	Fuse (F1)	SHENZHEN GREAT ELECTRONICS CO LTD	RXF-2W	2W, 7.5Ω.	cURus
			SHENZHEN YUZHOUXIN ELECTRONIC CO LTD	XRF-1W	1W, 7.5Ω.	cURus
207	106 b	Varistor (RV1)	Various	07D561K	SPD type 5. Rated 320Vac, min. 125°C.	cURus
207	106 c	Y-capacitor (CY1)	Various	Various	Y1, 2200pF, min. 400Vac, 125°C min.	cURus
207, 221, 221a	106 d	Transformer (T1)	SHENZHEN JINHUADA ELECTRONICS CO., LTD.	TR031A	0.7mH,Construction detailed, refer to Illustration 84a.	See 5.0
207	106f	Line Choke (LF1)	Various	Various	30mH,Consisted of item 106f1 and 106f2.	NR
207	106 f1	Magnetic wire of LF1	Various	Various	Polyurethane, rated 130°C min.	UR
					L1: φ 0.25 mm, 120Ts L2: φ 0.25 mm, 120Ts	
207	106 f2	Bobbin of LF1	Various	Various	PMC, V-0, 150°C, 0.45 mm thick min.	UR
207	106 g	Line Choke (LF2)	Various	Various	1mH, Consisted of item 106g1.	NR
207	106 g1	Magnetic wire of LF2	Various	Various	Polyurethane, rated 130°C min.	UR
					N1 & N2: 0.45mm in diameter, 16 turns.	
207	106 h	Inductor (L1)	Various	Various	1mH · Consisted of item 106h1, 106h2. Refer 7.0 illustration No. 84c for detail construction.	NR
207	106 h1	Magnetic wire of L1	Various	Various	Polyurethane, rated 130°C min.	UR
					N1: 0.27mm in diameter, 100 turns.	
193, 196a	107	Driver enclosure	Various	Various	Painted steel, 0.81mm thick.	NR

4.0 Critical Components						
Photo #	Item no. <sup>1</sup>	Name	Manufacturer/ trademark <sup>2</sup>	Type / model <sup>2</sup>	Technical data and securement means	Mark(s) of conformity <sup>3</sup>
188, 193, 196a, 199a	109	Bushing (Not shown)	Various	Various	Plastic, non-rubber type, rated min. HB, 80°C, 1.0mm thick.	cURus
193, 195, 199	110	Strain relief bushing	Various	Various	PC or PE, 85°C. 1.2mm thick min. Used to protect input and output wire of LED driver from sharp edge. Physically fitted to metal enclosure.	UR
193, 196a, 199a	111	Input wire	Various	Various	Black and white, AWM, 2 x 18AWG, rated min. 300V, 105°C, VW-1.	UR
193, 196a, 199a	112	Grounding wire	Various	Various	Green, AWM, 18AWG, rated min. 300V, 105°C, VW-1. Secured to driver enclosure by screw.	UR
193, 196a, 199a	113	Insulation sheet	Various	Various	PET, VTM-2, 105°C, HAI=min.2, HWI=min.2, CTI=min.4, min.5000V dielectric strength.0.18mm thick min. Fully cover the LED driver.	UR
202, 204, 205, 207, 209	114	Heat shrinkable tube (Not shown)	Various	Various	Rated min. 300V, 125°C, VW-1. Covered PCB assembly of LED driver; Covered fusing resistor.	cURus
202, 203, 204, 205, 208, 209	115	Driver PCB	Various	Various	Single layer printed wiring board, V-0, 130°C, 1.2mm thick min. CTI = 3. Complied UL 796.	UR
202, 204, 205, 207, 207a, 209	116	Material of output on-board connector	Various	Various	PC, rated min. HB, 90°C, 1.0mm thick.	UR
202, 204	117	Material of color temperature switch	Various	Various	PC, rated min. HB, 90°C, 1.0mm thick.	UR

4.0 Critical Components						
Photo #	Item no. <sup>1</sup>	Name	Manufacturer/ trademark <sup>2</sup>	Type / model <sup>2</sup>	Technical data and securement means	Mark(s) of conformity <sup>3</sup>
202, 204	117 a	PCB of color temperature switch (Not shown)	Various	Various	Single layer printed wiring board, min. V-0, 105°C, 1.0mm thick min.	UR
191, 192	118	Wiring compartment 4	Various	Various	Sheet steel, Dimensions of space for field wiring: 86mm x 42mm x 31mm. Provided two conduit openings with diameter 22.2mm, Min thickness: 0.66mm for junction box body and cover, secured on body by snap-fit.	NR
195, 196	119	Wiring compartment 5	Various	Various	Sheet steel, Dimensions of space for field wiring: 54mm x 29mm x 42mm. Provided one conduit openings with diameter 22.2mm, Min thickness: 0.66mm for junction box body and cover, secured on body by snap-fit.	NR
198, 199	120	Wiring compartment 6	Various	Various	Sheet steel, Dimensions of space for field wiring: 75mm x 80mm x 32mm. Provided three conduit openings with diameter 22.2mm, Min thickness: 0.66mm for junction box body and cover, secured on body by snap-fit.	NR
188	121	Wiring compartment 7	Various	Various	Sheet steel, Dimensions of space for field wiring: 81mm x 45mm x 29mm. Provided two conduit openings with diameter 22.2mm, Min thickness: 0.66mm for junction box body and cover, secured together by screws and snap-fit.	NR
144, 148, 152, 156, 160, 164, 168, 172, 176, 184	122	Marking Label (Not shown)	Various	Various	Min. 90°C on metal surface. Complied with UL969.	UR
211	123	Wiring compartment 8	Various	Various	Aluminum, min. volume of space for field wiring: min. 73.8cm <sup>3</sup> . Provided two conduit openings with diameter 22.2mm, Min thickness: 0.81mm for junction box body and cover, secured together by screws and snap-fit.	NR

4.0 Critical Components						
Photo #	Item no. <sup>1</sup>	Name	Manufacturer/ trademark <sup>2</sup>	Type / model <sup>2</sup>	Technical data and securement means	Mark(s) of conformity <sup>3</sup>
211, 215	124	Bushing	Various	Various	Plastic, non-rubber type, rated min. HB, 80°C, 1.0mm thick.	cURus
212, 215	125	Input wire	Various	Various	Black and white, AWM, 2 x 18AWG, rated min. 300V, 105°C, VW-1.	cURus
212, 215	126	Grounding wire	Various	Various	Green, AWM, 18AWG, rated min. 300V, 80°C, VW-1. Secured to driver enclosure by screw.	cURus
212, 215	127	Material for output connector	Various	Various	LCP, rated min. HB, 80°C, min 2.5mm thick.	cURus
212, 215	128	Output wire	Various	2464	AWM, rated min. 22AWG, 300V, 80°C, VW-1.	cURus
212, 215	129	Strain relief bushing	Various	Various	PC or PE, 85°C. 1.2mm thick min. Used to protect input and output wire of LED driver from sharp edge. Physically fitted to metal enclosure.	UR
212, 215	130	Insulation sheet	Various	Various	PET, VTM-2, 105°C, HAI=min.2, HWI=min.2, CTI=min.4, min.5000V dielectric strength.0.18mm thick min. Under the LED driver.	UR
215	130 a	Glue (not shown)	Various	Various	Silicone, min. 110°C, used to secure the insulation sheet and driver PCB.	UR
215a	130 b	Insulated tape	Various	Various	PET film insulating tapes with acrylic adhesive, rated 130°C.	UR
212	131	Heat shrinkable tube	Various	Various	Rated min. 300V, 125°C, VW-1. Covered PCB assembly of LED driver. Used to maintain min. 3.00mm spacing between Live part and metal case.	cURus
214	132	Wiring compartment 9	Various	Various	Sheet steel, Dimensions of space for field wiring: 85mm x 43mm x 31mm. Provided two conduit openings with diameter 22.2mm, Min thickness: 0.66mm for junction box body and cover , secured on body by snap-fit .	NR
216	133	LED Driver-21	Shenzhen goldsuno opto-electronic technology Co. Ltd.	TR120A	LVLE output, phase cut type dimming. Input: 120V, 60Hz, Max. 8W. Output: 21-30Vdc, 0.22A. Consisted of item 134 to 142.	See 5.0

4.0 Critical Components						
Photo #	Item no. <sup>1</sup>	Name	Manufacturer/ trademark <sup>2</sup>	Type / model <sup>2</sup>	Technical data and securement means	Mark(s) of conformity <sup>3</sup>
216a	133a	LED Driver-22	Shenzhen goldsuno opto-electronic technology Co. Ltd.	TR120B	LVLE output, phase cut type dimming. Input: 120V, 60Hz, Max. 12W. Output: 30-38Vdc, max. 0.26A. Consisted of item 134 to 138, 140 to 143.	See 5.0
216, 216a	134	Fuse resistor (F1)	SHENZHEN GREAT ELECTRONICS CO LTD	RXF-1W Series	22Ω, 1W.	cURus
216, 216a	134a	Heat shrinkable tube of F1	Various	Various	300V/600V. 125°C. VW-1.	cURus
216, 216a	135	Varistor (VR1)	Various	Various	SPD type 5. Min. 175Vac, min. 105°C.	cURus
216, 216a	136	Inductor (LF1)	Various	Various	25mH.Consisted of following items 136a-136d, refer 7.0 illustration No. 89 for detail construction.	NR
216, 216a	136a	Magnet wire of LF1 (Not shown)	Various	2UEW	Polyurethane, rated min. 130°C.	UR
216, 216a	136b	Insulated tape of LF1 (Not shown)	Various	Various	PET film insulating tapes with acrylic adhesive, rated 130°C.	UR
216, 216a	136c	Varnish of LF1 (Not shown)	Various	Various	Rated 130°C min.	UR
216, 216a	136d	Bobbin of LF1 (Not shown)	Various	Various	PMC, V-0, min. 130°C, HWI=1, HAI=0, CTI=3, measured min. 0.65mm thick.	UR
216, 216a	137	Inductor (L1)	Various	Various	2.2mH.Consisted of following items 137a, 137b, refer 7.0 illustration No. 90 for detail construction.	NR
216, 216a	137a	Magnet wire of L1 (Not shown)	Various	Various	Polyurethane, rated min. 130°C.	UR
216, 216a	137b	Heat shrinkable tube of L1 (Not shown)	Various	Various	600V. 125°C. VW-1.	cURus
216, 216a	138	Y-capacitor (CY1)	Various	Various	Y1, 2200pF, min. 400Vac, 125°C min.	cURus

4.0 Critical Components						
Photo #	Item no. <sup>1</sup>	Name	Manufacturer/ trademark <sup>2</sup>	Type / model <sup>2</sup>	Technical data and securement means	Mark(s) of conformity <sup>3</sup>
216, 218, 218a, 218b	139	Transformer (T1)	SHENZHEN JINHUADA ELECTRONICS CO.,LTD.	TR120A	1.8mH, Input: 120V, 60Hz, Max. 8W. Output: 21-30Vdc, 0.22A. Consist of 139a to 139h. Refer to Illustration 87 for the construction drawing.	NR
216, 218, 218a	139 a	Insulation system of T1 (Not shown)	HANG SING INDUSTRIAL CO LTD	HSSBI4.2	Class B insulation system	cURus
216, 218, 218a, 218b	139 b	Core of T1 (Not shown)	Various	Various	Ferrite, Wrapped with 2 layers of insulation tape.	NR
216, 218, 218a, 218b	139 c	Bobbin of T1 (Not shown)	Various	Various	Phenolic Molding Compound (PMC), rated min. V-0, 150°C, measured min. 1.65mm thick.	UR
216, 218, 218a, 218b	139 d	Magnet wire of T1 (Not shown)	Various	Various	Polyurethane, rated min. 155°C.	UR
216, 218, 218a, 218b	139 e	Triple Insulated Wire of T1 (Not shown)	Various	Various	Reinforced insulation, rated min. 155°C.	UR
216, 218, 218a, 218b	139f	T.F Tubing of T1 (Not shown)	Various	Various	Polytetrafluoroethylene (PTFE) not-heat-shrinkable tubing, rated min. 300V, 200°C.	UR
216, 218, 218a, 218b	139 g	Insulation tape of T1 (Not shown)	Various	Various	Polyethylene terephthalate film tapes, rated min. 180°C, min. 0.025 mm thick per layer.	UR
216, 218, 218a, 218b	139 h	Varnish of T1 (Not shown)	Various	Various	Rated min. 155°C.	UR

4.0 Critical Components						
Photo #	Item no. <sup>1</sup>	Name	Manufacturer/ trademark <sup>2</sup>	Type / model <sup>2</sup>	Technical data and securement means	Mark(s) of conformity <sup>3</sup>
216, 216a	140	Inductor LF2	Various	Various	Min. 1.5mH. Consisted of item 140a. Refer 7.0 illustration No. 91 for detail construction.	NR
216, 216a	140 a	Magnet wire of LF2	Various	Various	Polyurethane, rated min. 130 °C.	UR
216, 216a	141	Material of output on-board connector	Various	Various	PC, rated min. HB, 90°C, 1.0mm thick.	UR
217	142	PCB of driver	Various	Various	Single layer printed wiring board, rated min. V-0, 130°C. 1.2mm thick min. CTI ≤ 4, Complied with UL796.	cURus
216a , 219, 219a	143	Transformer (T1)	Shenzhen xinliante Electronics Co. LTD	TR120B	1.6mH, Input: 120V, 60Hz, Max. 12W. Output: 30-38Vdc, max. 0.26A. Consist of 143a to 143h. Refer to Illustration 88 for the construction drawing.	NR
216a , 219, 219a	143 a	Insulation system of T1 (Not shown)	HANG SING INDUSTRIAL CO LTD	HSSBI4.2	Class B insulation system	cURus
216a , 219, 219a	143 b	Core of T1 (Not shown)	Various	Various	Ferrite, Wrapped with 2 layers of insulation tape.	NR
216a , 219, 219a	143 c	Bobbin of T1 (Not shown)	Various	Various	Phenolic Molding Compound (PMC), rated min. V-0, 155°C, measured min. 1.65mm thick.	UR
216a , 219, 219a	143 d	Magnet wire of T1 (Not shown)	Various	Various	Polyurethane, rated min. 155°C.	UR
216a , 219, 219a	143 e	Triple Insulated Wire of T1 (Not shown)	Various	Various	Reinforced insulation, rated min. 155°C.	UR
216a , 219, 219a	143f	T.F Tubing of T1 (Not shown)	Various	Various	Polytetrafluoroethylene (PTFE) not-heat-shrinkable tubing, rated min. 150V, 200°C, VW-1.	UR
216a , 219, 219a	143 g	Insulation tape of T1 (Not shown)	Various	Various	Polyethylene terephthalate film tapes, rated min. 180°C, min. 0.025 mm thick per layer.	UR

4.0 Critical Components						
Photo #	Item no. <sup>1</sup>	Name	Manufacturer/ trademark <sup>2</sup>	Type / model <sup>2</sup>	Technical data and securement means	Mark(s) of conformity <sup>3</sup>
216a, 219, 219a	143h	Varnish of T1 (Not shown)	Various	Various	Rated min. 155°C.	UR
222, 226, 230, 234, 238, 242, 246, 250, 258, 262, 266, 270	144	Trim	Various	Various	Steel, 1.0mm thick min	NR
223, 227, 231, 235, 239, 243, 247, 251, 259, 263, 267, 271	144a	Back plate	Various	Various	Steel, 0.66mm thick min. Secured to trim by screws.	NR
223, 227, 231, 235, 239, 243, 247, 251, 259, 263, 267, 271	145	Spring clip	Various	Various	Carbon steel, diameter min. 8.0mm, for mounting bracket	NR
223, 227, 231, 235, 239, 243, 247, 251, 259, 263, 267, 271	146	Bushing	Various	Various	Polycarbonate, 105°C min. 1.2mm thick min. for protection the output wire of LED driver	UR

4.0 Critical Components						
Photo #	Item no. <sup>1</sup>	Name	Manufacturer/ trademark <sup>2</sup>	Type / model <sup>2</sup>	Technical data and securement means	Mark(s) of conformity <sup>3</sup>
223, 227, 231, 235, 239, 243, 247, 251, 259, 263, 267, 271	147	Material of cable clip	Various	Various	PE, 105°C, 1.2mm thick.	UR
223, 227, 231, 235, 239, 243, 247, 251, 259, 263, 267, 271	148	Output wire	Various	2464	AWM, Rated min. 3 x 24AWG, 300V, 80°C.	UR
255	148 a	Output wire	Various	Various	Rated min. 3 x 24AWG, 300V, 90°C.	UR
223, 227, 231, 235, 239, 243, 247, 251, 255, 259, 263, 267, 271	149	Material for connector	Various	Various	PC. HB, min.105°C, 1.5mm thick	cURus
224, 228, 232, 236, 240, 244, 248, 252, 260, 264, 268, 272	150	Diffuser	Various	Various	PC. HB, min. 80°C, 1.3mm thick	UR

4.0 Critical Components						
Photo #	Item no. <sup>1</sup>	Name	Manufacturer/ trademark <sup>2</sup>	Type / model <sup>2</sup>	Technical data and securement means	Mark(s) of conformity <sup>3</sup>
224, 228, 232, 236, 240, 244, 248, 252, 260, 264, 268, 272	151	Light guide plate	Various	Various	PC or PMMA, V-0, Min 80°C, 3.0mm thick min.	UR
224, 228, 232, 236, 240, 244, 248, 252, 260, 264, 268, 272	152	Reflector	Various	Various	PET, min.80°C, min. 0.2 mm thick.	UR
225, 229, 233, 237, 241, 245, 249, 253, 261, 265, 269, 273	153	LED PCB	Various	Various	Flexible PCB. Rated min. V-1, 130°C, measured min 0.8 mm thick. CTI = 3 or better. Complied UL 796.	UR
225, 229, 233, 237, 241, 245, 249, 253, 261, 265, 269, 273	154	LED	Various	Various	If=150mA, Vf=2.8-3.6V.	NR
261, 265, 269, 273	154 a	LED	Various	Various	RGB LED, Vf = 2.4-3.4V, If = 150mA.	NR
274	155 b	Output wire	Various	CL2	3C x 22AWG. 300V. Min. 80°C. VW-1.	cULus
			Various	2464	3C x 22AWG. 300V. Min. 80°C. VW-1.	cURus

4.0 Critical Components						
Photo #	Item no. <sup>1</sup>	Name	Manufacturer/ trademark <sup>2</sup>	Type / model <sup>2</sup>	Technical data and securement means	Mark(s) of conformity <sup>3</sup>
274	155 c	Material of connector	Various	Various	PC. HB, min. 75°C, 1.5mm thick	cURus
255	155	Clip	Various	Various	Two provided. Steel. Φ1.2mm. Secured to heatsink by screw.	NR
255	156	Strain relief	Various	Various	PC,105°C, HB, 1.2mm thick. Secured to heat sink by screw.	UR
256	157	Trim	Various	Various	Die-cast aluminum, 2mm thick min.	NR
256	158	Trim housing	Various	Various	Die-cast aluminum, 2mm thick min.	NR
256	159	Heat sink	Various	Various	Aluminum,1.5mm thick min., wire entrance are smooth and no sharp edge.	NR
256	160	Heat sink cover	Various	Various	PC,105°C, HB, 1.2mm thick. Secured to heat sink by physical fit.	UR
256	161	gasket	Various	Various	Silicone, min. 220°C, min. 0.5 mm thick. Placed on trim.	UR
256	162	Diffuser	Various	Various	PC. HB. Min. 120°C. 1.5mm thick.	UR
256	163	Diffuser cover	Various	Various	PC. HB. Min. 120°C. 2.3mm thick.	UR
257	164	LED frame	Various	Various	PC, rated min. HB, 115°C, 1.0mm thick	cURus
257	165	LED	Various	Various	COB. Vf= max. 42V, If=240mA	NR
275	166	Wiring compartment 10	Various	Various	Sheet steel, Dimensions of space for field wiring: 65mm x 53mm x 33mm. Provided two conduit openings with diameter 22.2mm, Min thickness: 0.66mm for junction box body and cover , secured on body by snap-fit and a screw.	NR
276, 281	167	Input wire	Various	Various	Black and white, AWM, 2 x 18AWG, rated min. 300V, 105°C, VW-1.	cURus
281	168	Grounding wire	Various	Various	Green, AWM, 18AWG, rated min. 300V, 80°C, VW-1. Secured to driver enclosure by screw.	cURus
275	168 a	Grounding wire-1	Various	Various	Bare copper wire, 18AWG. Secured to driver enclosure by a screw.	NR
276, 281	169	Bushing	Various	Various	Plastic, non-rubber type, rated min. HB, 80°C, 1.0mm thick.	cURus
276	170	Material for strain relief bushing	Various	Various	PC. HB, min.105°C, 1.5mm thick.	cURus
276, 281	171	Insulated sheet	SICHUAN DONGFANG INSULATING MATERIAL CO LTD	DFPET 6023	PET, VTM-2, 105°C, HAI=5, HWI=4, CTI=2, measured min 0.18 mm thick min. Fully cover the LED driver.	UR

4.0 Critical Components						
Photo #	Item no. <sup>1</sup>	Name	Manufacturer/ trademark <sup>2</sup>	Type / model <sup>2</sup>	Technical data and securement means	Mark(s) of conformity <sup>3</sup>
277	172	LED Driver-23	Shenzhen goldsuno opto-electronic technology Co. Ltd.	TR-125	LVLE output, phase cut type dimming. Input: 120V, 60Hz, Max. 12W. Output: 21-40Vdc, 0.29A. Consisted of item 173 to 179.	See 5.0
278a	172 a	LED Driver-26	Shenzhen goldsuno opto-electronic technology Co. Ltd.	TR-063	LVLE output, phase cut type dimming. Input: 120V, 60Hz, Max. 12W. Output: 21-40Vdc, 0.29A. Consisted of item 173, 173a, 175-179.	See 5.0
277, 278a	173	Fuse resistor (F1)	SHENZHEN GREAT ELECTRONICS CO LTD	RXF-2W Series	22Ω, 2W.	cURus
277, 278a	173 a	Heat shrinkable tube of F1	Various	Various	300V/600V. 125°C. VW-1.	cURus
277	174	Varistor (VR1)	Various	7D471K	SPD type 5. Min. 175Vac, min.85°C.	cURus
277, 278a	175	Y-capacitor (CY1)	Various	Various	Y1, 1000pF, min. 400Vac, 125°C min.	cURus
277, 278a	176	Transformer (T1)	SHENZHEN JINHUADA ELECTRONICS CO., LTD.	TR-125	1.85mH. (5-1) Input: 120V, 60Hz, Max. 12W. Output: 21-40Vdc, 0.29A. consist of 176a to 176g. Refer to Illustration 94 for the construction drawing.	NR
277, 278a	176 a	Insulation system of T1 (Not shown)	HANG SING INDUSTRIAL CO LTD	HSSBI4.2	Class B insulation system	cURus
277, 278a	176 b	Core of T1 (Not shown)	Various	Various	Ferrite, Wrapped with 2 layers of insulation tape.	NR
277, 278a	176 c	Bobbin of T1 (Not shown)	Various	Various	Phenolic Molding Compound (PMC), rated min. V-0, 155°C, measured min. 0.75mm thick.	UR
277, 278a	176 d	Magnet wire of T1 (Not shown)	Various	Various	Polyurethane, rated min. 130°C.	UR
277, 278a	176 e	Triple Insulated Wire of T1 (Not shown)	Various	Various	Reinforced insulation, rated min. 130°C.	UR
277, 278a	176f	T.F Tubing of T1 (Not shown)	Various	Various	Polytetrafluoroethylene (PTFE) not-heat-shrinkable tubing, rated min. 150V, 200°C.	UR
277, 278a	176 g	Insulation tape of T1 (Not shown)	Various	Various	Polyethylene terephthalate film tapes, rated min. 130°C, min. 0.025 mm thick per layer.	UR
277, 278a	177	Material of output on-board connector	Various	Various	PC, rated min. HB, 90°C, 1.0mm thick.	UR
277, 278a	178	Switch knob	Various	Various	PVC, min. HB, 80°C, measured min. 1.9 mm thick.	UR

4.0 Critical Components						
Photo #	Item no. <sup>1</sup>	Name	Manufacturer/ trademark <sup>2</sup>	Type / model <sup>2</sup>	Technical data and securement means	Mark(s) of conformity <sup>3</sup>
277, 278a	178 a	PCB for switch knob (not show)	Various	Various	Single layer PCB. V-1, 105°C, CTI=3 or better. 1.2mm thick min. Complied UL796.	UR
278, 278b	179	PCB of driver	Various	Various	Single layer printed wiring board, rated min. V-0, 130°C. 1.2mm thick min. CTI ≤ 4, Complied with UL796.	cURus
280	180	Wiring compartment 11	Various	Various	Sheet steel, Dimensions of space for field wiring: 85mm x 42mm x 30mm. Provided two conduit openings with diameter 22.2mm, Min thickness: 0.66mm for junction box body and cover , secured on body by screw.	NR
281	181	Glue	Various	Various	Silicone, min. 110°C, used to secure the insulation sheet and driver PCB.	UR
281	182	Strain relief bushing	Various	Various	PC or PE, 85°C, 1.2mm thick min. Used to protect input and output wire of LED driver from sharp edge. Physically fitted to metal enclosure.	UR
282	183	LED Driver-24	Shenzhen goldsuno opto-electronic technology Co. Ltd.	TR-053	LVLE output, Provide with WIFI dimming function. Input: 120V, 60Hz, Max. 10W. Output: 25-27Vdc, 0.24A. Consisted of item 184 to 189.	See 5.0
282	183 a	LED Driver-25	Shenzhen goldsuno opto-electronic technology Co. Ltd.	TR-054	LVLE output, Provide with WIFI dimming function. Input: 120V, 60Hz, Max. 12W. Output: 25-36Vdc, 0.24A. Consisted of item 184 to 189.	See 5.0
282	184	Fuse resistor (F1)	SHENZHEN GREAT ELECTRONICS CO LTD	RXF-1W Series	22Ω, 1W.	cURus
282	184 a	Heat shrinkable tube of F1	Various	Various	300V/600V. 125°C. VW-1.	cURus
282	185	Y-capacitor (CY1)	Various	Various	Y1, 1000pF, min. 400Vac, 125°C min.	cURus
282	186	Transformer (T1)	Shenzhen Jingyu Lighting Technology Co., LTD	JY-TR053-10W	1.9mH, Input: 120V, 60Hz, Max. 10W. Output: 25-27Vdc, 0.24A. Consist of 186b to 186h. Refer to Illustration 97 for the construction drawing. For driver model TR-053.	NR
282	186 a	Transformer (T1)	Shenzhen Jingyu Lighting Technology Co., LTD	JY-TR054-12W	1.9mH, Input: 120V, 60Hz, Max. 12W. Output: 25-36Vdc, 0.24A. consist of 186b to 186h. Refer to Illustration 98 for the construction drawing. For driver model TR-054.	NR

4.0 Critical Components						
Photo #	Item no. <sup>1</sup>	Name	Manufacturer/ trademark <sup>2</sup>	Type / model <sup>2</sup>	Technical data and securement means	Mark(s) of conformity <sup>3</sup>
282	186 b	Insulation system of T1 (Not shown)	HANG SING INDUSTRIAL CO LTD	HSSBI4.2	Class B insulation system	cURus
282	186 c	Core of T1 (Not shown)	Various	Various	Ferrite, Wrapped with 2 layers of insulation tape.	NR
282	186 d	Bobbin of T1 (Not shown)	Various	Various	Phenolic Molding Compound (PMC), rated min. V-0, 155°C, measured min. 0.75mm thick.	UR
282	186 e	Magnet wire of T1 (Not shown)	Various	Various	Polyurethane, rated min. 130°C.	UR
282	186f	Triple Insulated Wire of T1 (Not shown)	Various	Various	Reinforced insulation, rated min. 130°C.	UR
282	186 g	T.F Tubing of T1 (Not shown)	Various	Various	Polytetrafluoroethylene (PTFE) not-heat-shrinkable tubing, rated min. 150V, 200°C.	UR
282	186 h	Insulation tape of T1 (Not shown)	Various	Various	Polyethylene terephthalate film tapes, rated min. 130°C, min. 0.025 mm thick per layer.	UR
282	187	Material of output on-board connector	Various	Various	PC, rated min. HB, 90°C, 1.0mm thick.	UR
282	188	Wifi module	YTL	CB3L	Rated VCC= 3.0-3.6V. Ts= -40°C-105°C. Consist of components 188a	NR
282	188 a	PCB of wifi module	Various	Various	Multi-layer printed wiring board, rated min. V-0, 130°C. CTI ≤ 4, Complied with UL796.	UR
283	189	PCB of driver	Various	Various	Multi-layer printed wiring board, rated min. V-0, 130°C. 1.2mm thick min. CTI ≤ 4, Complied with UL796.	cURus
284	190	Trim	Various	Various	Sheet aluminum, 1.0mm thick min,	NR
284	191	Diffuser	Various	Various	PC, HB, min. 80°C, 1.0mm thick	UR
285	192	Fixed ring	Various	Various	Sheet aluminum, 1.3mm thick.	NR
285	193	Heat sink	Various	Various	Extruded aluminum. 1.41mm thick min. Wire entrance is smooth and no sharp edge.	NR
285	194	Metal conduit	Various	Various	Sheet aluminum, 0.5mm thick min., 9.2mm in dia, secured by mechanical mean.	NR
286	195	Reflector	Various	Various	PBT, Measured 0.6 mm thick min., 125°C.	UR
286	196	Mounting Clamp	Various	Various	Two provide. Steel. 1.0mm thick. May be provided with metal or plastic housing. Secured to housing by screws or snap fitting.	NR
287	197	LED	Various	Various	Vf = max. 3.3V, If = max. 150mA.	NR
287	198	LED PCB	Various	Various	Single layer metal base, rated min. V-0, 130°C, 1.0mm thick.	UR
287	199	Output wire	Various	Various	2 x 22AWG. 300V. Min. 105°C. VW-1.	UR

4.0 Critical Components						
Photo #	Item no. <sup>1</sup>	Name	Manufacturer/ trademark <sup>2</sup>	Type / model <sup>2</sup>	Technical data and securement means	Mark(s) of conformity <sup>3</sup>
288	200	Input wire	Various	Various	Black and white, AWM, 2 x 18AWG, rated min. 300V, 105°C, VW-1.	UR
288	201	Bushing	Various	Various	Plastic, non-rubber type, rated min. HB, 80°C, 1.0mm thick.	cURus
288	202	Insulation sheet	Various	Various	PET, VTM-2, 105°C, HAI=min.2, HWI=min.2, CTI=min.4, min.5000V dielectric strength.0.18mm thick min. Fully cover the LED driver.	UR
288	203	Potting compound	SHENZHENSHI HUATIANQI TECHNOLOGY CO LTD	CS-874, CS-9811	Silicone "Room Temperature Vulcanizing" (RTV), V-0, 105°C. Completely filled and covered the LED driver	cURus
288	204	Grounding wire	Various	Various	Green, AWM, 18AWG, rated min. 300V, 80°C, VW-1. Secured to driver enclosure by screw.	cURus
222, 226, 230, 234, 238, 242, 246, 250, 254, 258, 262, 266, 270, 284	205	Marking Label (Not shown)	Various	Various	Min. 90°C on metal surface. Complied with UL969.	UR
295	206	Input wire	Various	Various	Black and white, AWM, 2 x 18AWG, rated min. 300V, 105°C, VW-1.	cURus
295	207	Grounding wire	Various	Various	Bare copper wire, 18AWG. Secured to driver enclosure by a rivet.	NR
295	208	Bushing	Various	Various	Non-rubber material, rated min. HB, 80°C, 1.2mm thick minimum.	cURus
295	209	Material for strain relief fittings	Various	Various	PC. HB, min.105°C, 1.5mm thick.	cURus
295	210	LED driver Barrier	Various	Various	PC, V-0, min. 105°C, HAI=3, HWI=3, CTI=4, measured min 0.8mm thick min. Fully covered the LED driver.	cURus
296	211	Insulated sheet	Various	Various	PET, VTM-2, min. 105°C, min. 5000V dielectric strength. 0.18mm thick min. Placed between Metal Enclosure and LED driver Barrier for insulation.	UR

4.0 Critical Components						
Photo #	Item no. <sup>1</sup>	Name	Manufacturer/ trademark <sup>2</sup>	Type / model <sup>2</sup>	Technical data and securement means	Mark(s) of conformity <sup>3</sup>
293, 297	212	LED Driver-27	Shenzhen goldsuno opto-electronic technology Co. Ltd.	TR-319	LVLE output, phase cut type dimming. Input: 120V, 60Hz, Max. 12W. Output: 30-40Vdc, 0.29A. Consisted of item 213 to 216.	See 5.0
297	213	Fuse resistor (F1)	SHENZHEN GREAT ELECTRONICS CO LTD	RXF-2W Series	22Ω, 2W.	cURus
297	213 a	Heat shrinkable tube of F1	Various	Various	300V/600V, Min.125°C. VW-1.	cURus
297	214	Varistor (VR1)	Various	7D471K	SPD type 5. Min. 175Vac, min. 85°C.	cURus
297	215	Transformer (T1)	Zhongshanshi Lemingge Electronic Industrial Co., Ltd	CNT-TR-125A	1.7mH. (3-1) Input: 120V, 60Hz, Max. 12W. Output: 30-40Vdc, 0.29A. consist of 215a to 215e. Refer to Illustration 101 for the construction drawing.	NR
297	215 a	Core of T1 (Not shown)	Various	Various	Ferrite, Wrapped with 2 layers of insulation tape.	NR
297	215 b	Bobbin of T1 (Not shown)	Various	Various	Phenolic Molding Compound (PMC), rated min. V-0, min. 155°C, measured min. 0.75mm thick.	UR
297	215 c	Magnet wire of T1 (Not shown)	Various	Various	Polyurethane, rated min. 130°C.	UR
297	215 d	Triple Insulated Wire of T1 (Not shown)	Various	Various	Reinforced insulation, rated min. 130°C.	UR
297	215 e	Insulation tape of T1 (Not shown)	Various	Various	Polyethylene terephthalate film tapes, rated min. 130°C, min. 0.025 mm thick per layer.	UR
298	216	PCB of driver	Various	Various	Single layer printed wiring board, rated min. V-0, min. 130°C. 1.2mm thick min. CTI ≤ 4, Complied with UL796.	cURus
295	217	Wiring compartment 12	Various	Various	Sheet steel, Dimensions of space for field wiring: 65.5mm x 54.0mm x 33.5mm. Provided three conduit openings with diameter 22.2mm, Min thickness: 0.66mm for junction box body and cover , secured on body by snap-fit and a screw.	NR

4.0 Critical Components						
Photo #	Item no. <sup>1</sup>	Name	Manufacturer/ trademark <sup>2</sup>	Type / model <sup>2</sup>	Technical data and securement means	Mark(s) of conformity <sup>3</sup>
293	218	Output wire	Various	CL2	3C x 22AWG. 300V. Min. 80°C. VW-1.	cULus
			Various	2464	3C x 22AWG. 300V. Min. 80°C. VW-1.	cURus
293	219	Material of connector	Various	Various	PC. HB, min.75°C, 1.5mm thick	cURus
301, 310, 311, 316, 317, 324, 325, 328	220	Trim/ enclosure	Various	Various	Aluminum. 1.2mm thick min. The wire entrance are smooth and no sharp eddge	NR
301, 310, 311, 313, 315, 321, 323	221	Mounting Clamp	Various	Various	Two provide. Steel.1.0mm thick. May be provided with metal or plastic housing. Secured to housing by screws or snap fitting.	NR
310	222	Clamp frame	Various	Various	Aluminum. 5mm thick.	NR
301, 310, 313, 315, 321, 323	223	Bushing	Various	Various	Plastic, non-rubber type, rated min. HB, 90°C, min. 1.0mm thick.	cURus
301, 310, 311, 315, 321, 323, 328, 331, 338	224	Output wire	Various	CL2	3C x 22AWG, rated min. 300V, 80°C. VW-1.	cULus
			Various	2464	3C x 22AWG, rated min. 300V, 80°C. VW-1.	cURus
301, 310, 311, 315, 321, 323, 328, 331, 338	225	Material of connector	Various	Various	PC or PVC, rated min. HB, 75°C, min. 1.5mm thick.	cURus
302- 307, 310, 311, 324, 325, 328	226	LED frame	Various	Various	PC, rated min. HB, 115°C, min. 1.0mm thick.	cURus

4.0 Critical Components						
Photo #	Item no. <sup>1</sup>	Name	Manufacturer/ trademark <sup>2</sup>	Type / model <sup>2</sup>	Technical data and securement means	Mark(s) of conformity <sup>3</sup>
311, 316, 317, 318, 319, 324, 325, 328	227	Diffuser	Various	Various	PC or PS, rated min. HB, 80°C, min. 1.0mm thick.	UR
316, 317, 318, 319	228	Light guide plate	Various	Various	PC , rated min. 80°C, min. 3.0mm thick.	UR
302-307, 311, 316, 318, 324	229	Reflector	Various	Various	PC or PBT, rated min. 80°C, min. 1.0mm thick.	UR
328	229 a	Reflector	Various	Various	PC or PMMA, rated min. HB, 120°C, min. 1.0mm thick.	UR
316, 317, 318, 319	230	Reflective paper	Various	Various	PET , rated min.80°C, min. 0.2 mm thick.	UR
302-307, 310	231	Lens	Various	Various	PC or PS, rated min. HB, 120°C. 1.0mm thick.	UR
234, 235	232	Diffuser frame	Various	Various	PC, rated min. HB, 80°C, 1.0mm thick	cURus
328	233	Diffuser mounting ring	Various	Various	Aluminum. 1.2mm thick.	NR
302-307, 310	234	COB LED	Various	Various	Rated max. If:300-690mA, Vf:42-48V, for model JXL-COB04-R15W-5CCT and JXL-COB04-S15W-5CCT	NR
			Various	Various	Rated max. If:300-690mA, Vf:27-29V, for model JXL-ZF03-T07W-5CCT	NR
			Various	Various	Rated max. If:300-690mA, Vf:36-42V, for model JXL-COB04-R12W-5CCT, JXL-COB06-R15W-5CCT, JXL-COB06-S15W-5CCT and JXL-COB04-S12W-5CCT	NR
			Various	Various	Rated max. If:300-690mA, Vf:30-36V, for model JXL-COB02-R9W-5CCT, JXL-COB02-S9W-5CCT and JXL-ZF03-T07W-5CCT	NR
328	234 a	LED	Various	Various	COB. Vf= max. 39V, If=max. 860mA	cURus

4.0 Critical Components						
Photo #	Item no. <sup>1</sup>	Name	Manufacturer/ trademark <sup>2</sup>	Type / model <sup>2</sup>	Technical data and securement means	Mark(s) of conformity <sup>3</sup>
311, 316, 317, 318, 319, 324, 325	235	LED	Various	Various	Rated max. If=150mA, Vf=2.8-3.6V. for model JXL-TZ03-T7W-5CCT	NR
			Various	Various	Rated max. If:150mA,Vf:3.1-3.3V, for model JXL-TA08-T18W-5CCT, JXL-TF08-T18W-5CCT, JXL-TZ06-T15W-5CCT, JXL-CA06-T15W-5CCT, JXL-SMD04-G12W-5CCT, JXL-TZ04-T10W-RGBCW, JXL-TZ06-T12W-RGBCW JXL-BK04-T10W-5CCT and JXL-BK06-T12W-5CCT	
			Various	Various	Rated max. If:240mA,Vf:5.8-6.2V,for mode JXL-TXH05-T11W-5CCT, JXL-TXH10-T18W-5CCT	
319	235 a	RGB LED	Various	Various	RGB LED, Vf = 2.4-3.4V, If = 150mA.	NR
302- 307, 310, 324, 325	236	LED PCB	Various	Various	Single layer metal base, rated min. V-0, 130°C, min. 1.0mm thick.	UR
316, 317, 318, 319	237	Flexible LED PCB	Various	Various	Flexible PCB. Rated min. V-1, 130°C, min 0.8 mm thick.	UR
311	238	Gasket	Various	Various	Silicone, min. 220°C, min. 0.5 mm thick. Placed on trim.	UR
319a	239	Wifi module	YTL	CB3L	Rated VCC= 3.0-3.6V. Ts= -40°C-105°C.	NR
319a	239 a	Wifi module PCB	Various	Various	Single layer metal base, rated min. V-0, 130°C, min. 1.0mm thick.	UR
319a	239 b	Material of Wire connector	Various	Various	Plastic, rated min. HB, 105°C, 0.5mm thick.	UR
331	240	Wiring compartment 13	Various	Various	Sheet steel, Dimensions of space for field wiring: 65.5mm x 54.0mm x 33.5mm. Provided two conduit openings with diameter 22.2mm, Min thickness: 0.66mm for junction box body and cover , secured on body by snap-fit and a screw.	NR
338	240 a	Wiring compartment 14	Various	Various	Sheet steel, Dimensions of space for field wiring: 71.5mm x 41.6mm x 28mm. Provided one conduit openings with diameter 22.2mm, Min thickness: 0.66mm for junction box body and cover , secured on body by snap-fit.	NR

4.0 Critical Components						
Photo #	Item no. <sup>1</sup>	Name	Manufacturer/ trademark <sup>2</sup>	Type / model <sup>2</sup>	Technical data and securement means	Mark(s) of conformity <sup>3</sup>
331	241	Insulation sheet	Various	Various	PET, VTM-2, 105°C, HAI=min.2, HWI=min.2, CTI=min.4, min.5000V dielectric strength.0.18mm thick min. Fully cover the LED driver.	UR
331, 338	242	Input wire	Various	Various	Black and white, AWM, 2 x 18AWG, rated min. 300V, 105°C, VW-1.	cURus
331	243	Grounding wire	Various	Various	Bare copper wire, 18AWG. Secured to driver enclosure by a rivet.	NR
338	243 a	Grounding wire	Various	Various	Green, AWM, 18AWG, rated min. 300V, 105°C, VW-1. Secured to driver enclosure by screw.	UR
331, 338	244	Bushing	Various	Various	Non-rubber material, rated min. HB, 80°C, 1.2mm thick minimum.	cURus
331, 338	245	Material for strain relief fittings	Various	Various	PC. HB, min.105°C, 1.5mm thick.	cURus
332, 333	246	LED Driver-28	Shenzhen goldsuno opto-electronic technology Co. Ltd.	TR-062	Phase cut type dimming. LVLE output Input: 120V, 60Hz, Max. 18W. Output: 42-58Vdc, 0.27A. Consisted of item 247 to 252.	See 5.0
332	247	Fuse resistor (F2)	Dongguan Xingrui Electrical and Mechanical Co Ltd	RXF21-2W	10Ω, 2W.	cURus
332	247 a	Heatshrinkable tube of F2	Various	Various	Rated min. 300V, 120°C	cURus
332	248	Y-capacitor (CY1)	Various	Various	Y1, 1000pF, min. 400Vac, 125°C min.	cURus
332	249	Inductor (L1)	Various	Various	2.5mH, Consisted of item 249a, 249b. Refer 7.0 illustration No. 104a for detail construction.	NR
332	249 a	Magnetic wire of L1	Various	Various	Polyurethane, rated 130°C min. N1: 0.2mm in diameter, 273 turns	UR
332	249 b	Heatshrinkable tube of L1	Various	Various	600V, 125°C, VW-1.	UR
332	250	Transformer (T1)	ZHONGSHAN HONGHUA ELECTRONICS CO., LTD	126-PQ2016	1.1mH. Input: 120V, 60Hz, Max. 18W. Output: 42-58Vdc, 0.27A. consist of 250a to 250e. Refer to Illustration 104 for the construction drawing.	NR
332	250 a	Core of T1 (Not shown)	Various	Various	Ferrite, Wrapped with 2 layers of insulation tape.	NR
332	250 b	Bobbin of T1 (Not shown)	Various	Various	Phenolic Molding Compound (PMC), rated min. V-0, min. 155°C, measured min. 0.75mm thick.	UR
332	250 c	Magnet wire of T1 (Not shown)	Various	Various	Polyurethane, rated min. 130°C.	UR

4.0 Critical Components						
Photo #	Item no. <sup>1</sup>	Name	Manufacturer/ trademark <sup>2</sup>	Type / model <sup>2</sup>	Technical data and securement means	Mark(s) of conformity <sup>3</sup>
332	250d	Triple Insulated Wire of T1 (Not shown)	Various	Various	Reinforced insulation, rated min. 130°C.	UR
332	250e	Insulation tape of T1 (Not shown)	Various	Various	Polyethylene terephthalate film tapes, rated min. 130°C, min. 0.025 mm thick per layer.	UR
332	250f	Insulation system of T1 (Not shown)	HANG SING INDUSTRIAL CO LTD	HSSBI4.2	Class B insulation system	UR
332	251	Switch knob	Various	Various	PA66, min. HB, 105°C, measured min. 1.9 mm thick.	UR
332	251a	PCB for switch (not shown)	Various	Various	Single layer PCB. V-1, 105°C. 1.2mm thick min.	UR
333	252	PCB of driver	Various	Various	Single layer printed wiring board, rated min. V-0, min. 130°C. 1.2mm thick min. CTI ≤ 4, Complied with UL796.	cURus
334, 335	253	LED Driver-29	Shenzhen goldsuno opto-electronic technology Co. Ltd.	TR-054B	LVLE output, Provide with WIFI dimming function. Input: 100-277V, 50/60Hz, Max. 12W. Output: 30-40Vdc, 0.27A.	See 5.0
334	254	Fuse resistor (FR1)	FOSHAN YUETAI ELECTRONIC TECHNOLOGY CO LTD	RXF-1W (0309)	0.47R, 1W.	cURus
334	254a	Heatshinkable tube of FR1	Various	Various	Rated min. 300V, 120°C	cURus
334	255	Y-capacitor (CY1)	Various	Various	Y1, 1000pF, min. 400Vac, 125°C min.	cURus
334	256	Transformer (T1)	Shenzhen Jingyu Lighting Technology Co., LTD	EE-1608	1.7-1.9mH. Input: 100-277V, 60Hz, Max. 12W. Output: 30-40Vdc, 0.27A. consist of 256a to 256e. Refer to Illustration 107 for the construction drawing.	NR
334	256a	Core of T1 (Not shown)	Various	Various	Ferrite, Wrapped with 2 layers of insulation tape.	NR

4.0 Critical Components						
Photo #	Item no. <sup>1</sup>	Name	Manufacturer/ trademark <sup>2</sup>	Type / model <sup>2</sup>	Technical data and securement means	Mark(s) of conformity <sup>3</sup>
334	256 b	Bobbin of T1 (Not shown)	Various	Various	Phenolic Molding Compound (PMC), rated min. V-0, min. 155°C, measured min. 0.75mm thick.	UR
334	256 c	Magnet wire of T1 (Not shown)	Various	Various	Polyurethane, rated min. 130°C.	UR
334	256 d	Triple Insulated Wire of T1 (Not shown)	Various	Various	Reinforced insulation, rated min. 130°C.	UR
334	256 e	Insulation tape of T1 (Not shown)	Various	Various	Polyethylene terephthalate film tapes, rated min. 130°C, min. 0.025 mm thick per layer.	UR
335	257	PCB of driver	Various	Various	Multi-layer printed wiring board, rated min. V-0, min. 130°C. 1.2mm thick min. CTI ≤ 4, Complied with UL796.	cURus
339, 340	258	LED Driver-30	Shenzhen goldsuno opto-electronic technology Co. Ltd.	TR-071	LVLE output, phase cut type dimming. Input: 120V, 60Hz, Max. 10W. Output: 30-42Vdc, 0.21A.	See 5.0
339	259	Fuse resistor (F1)	SHENZHEN GREAT ELECTRONICS CO LTD	RXF-2W Series	22Ω, 2W.	cURus
339	259 a	Heatshinkable tube of F1	Various	Various	Rated min. 300V, 120°C	cURus
339	260	Transformer (T1)	Shenzhen Jingyu Lighting Technology Co., LTD	EE-1608-3	1.8-2.2mH. Input: 120V, 60Hz, Max. 10W. Output: 30-42Vdc, 0.21A. consist of 260a to 260e. Refer to Illustration 110 for the construction drawing.	NR
339	260 a	Core of T1 (Not shown)	Various	Various	Ferrite, Wrapped with 2 layers of insulation tape.	NR
339	260 b	Bobbin of T1 (Not shown)	Various	Various	Phenolic Molding Compound (PMC), rated min. V-0, min. 155°C, measured min. 0.75mm thick.	UR
339	260 c	Magnet wire of T1 (Not shown)	Various	Various	Polyurethane, rated min. 130°C.	UR
339	260 d	Triple Insulated Wire of T1 (Not shown)	Various	Various	Reinforced insulation, rated min. 130°C.	UR
339	260 e	Insulation tape of T1 (Not shown)	Various	Various	Polyethylene terephthalate film tapes, rated min. 130°C, min. 0.025 mm thick per layer.	UR
339	261	CCT Switch knob	Various	Various	PVC, min. HB, 80°C, measured min. 1.9 mm thick.	UR
339	261 a	PCB for switch (not shown)	Various	Various	Single layer PCB. V-1, 105°C. 1.2mm thick min.	UR
340	262	PCB of driver	Various	Various	Multi-layer printed wiring board, rated min. V-0, min. 130°C. 1.2mm thick min. CTI ≤ 4, Complied with UL796.	cURus

4.0 Critical Components						
Photo #	Item no. <sup>1</sup>	Name	Manufacturer/ trademark <sup>2</sup>	Type / model <sup>2</sup>	Technical data and securement means	Mark(s) of conformity <sup>3</sup>
332, 339	263	Material of output on-board connector	Various	Various	PC, rated min. HB, 90°C, 1.0mm thick.	UR
300, 308, 312, 314, 320, 322, 326	264	Marking Label (Not shown)	Various	Various	Min. 90°C on metal surface. Complied with UL969.	UR

## NOTES:

- 1) Not all item numbers are indicated (called out) in the photos, as their location is obvious.
- 2) "Various" means any type, from any manufacturer that complies with the "Technical data and securement means" and meets the "Mark(s) of conformity" can be used.
- 3) Indicates specific marks to be verified, which assures the agreed level of surveillance for the component. "NR" - indicates Unlisted and only visual examination is necessary. "See 5.0" indicates Unlisted components or assemblies to be evaluated periodically refer to section 5.0 for details.

**5.0 Critical Unlisted CEC Components**

**INSULATED COIL**

Photo #	Item no.	Name	Manufacturer/Trademark	Type / model
18	29	Transformer 1 (T1)	Shenzhen Huaxinda Electronic Co., Ltd.	TR017
Electrical Rating: 1200uH.				Insulation class NA
Component Standard used:		UL 8750:2015 Ed.2+R:23Sep2021 CSA C22.2#250.13:2020 Ed.4+U1		

**MATERIALS LIST** (refer to illustration 18-19 for assembly drawing)

Component	Manufacturer	Type/model	Dimensions/thickness/assembly information
Primary Winding of T1 (N1, N2, N4)	Various	2UEW	Polyurethane, rated 130°C. (UR)
Secondary Winding of T1 (N3)	Various	TEX-E	Triple insulated wire, rated 130°C. (UR)
Bobbin of T1	Various	Various	PMC, V-0, 150°C, 0.45 mm thick min (cURus)
Insulated tape of T1	Various	Various	Polyethylene terephthalate film insulating tapes, yellow, rated 130°C, 0.025 mm thick per layer. Min. 2 layers are provided as outer wrap and between windings. (UR)
Varnish of T1	Various	Various	Rated 130°C. (UR)
TF Tube	Various	Various	Rated 300V, 200°C. (UR)

**WINDING(S) RESISTANCE**

Winding Designation	Wire Size (AWG or mm <sup>2</sup> )	Wire Type	Turns	Volts	Amps	DC resistance (Ω) +/- 10%:
N1	Φ0.2*1P	Magnetic wire	52	NA	NA	NA
N2	Φ0.2*1P	Magnetic wire	1	NA	NA	NA
N3	Φ0.2*1P	Triple insulated wire	50	NA	NA	NA
N4	Φ0.2*1P	Magnetic wire	52	NA	NA	NA

**VERIFICATION PROCESS**

Frequency: <b>Annual</b>	Test Site: <b>CEC</b>	Number of samples to test: <b>1</b>	
Test Name	Test Parameters		
Winding resistance	See resistance per winding above.		
Dielectric Strength	Apply voltage Between	Test Voltage	Test Time
	Primary to core	1240	1min
	Primary to secondary	1240	1min
	Secondary to core	1240	1min

**5.0 Critical Unlisted CEC Components**

**INSULATED COIL**

Photo #	Item no.	Name	Manufacturer/Trademark	Type / model
28	39	Transformer 2 (T1)	Shenzhen Huzxinda Electronic Co., Ltd.	TR012

Electrical Rating: 1200uH. Insulation class NA

Component Standard used: UL 8750:2015 Ed.2+R:23Sep2021  
 CSA C22.2#250.13:2020 Ed.4+U1

**MATERIALS LIST (refer to illustration 20-21 for assembly drawing)**

Component	Manufacturer	Type/model	Dimensions/thickness/assembly information
Primary Winding of T1 (N1, N3)	Various	2UEW	Polyurethane, rated 130°C. (UR)
Secondary Winding of T1 (N2)	Various	TEX-E	Triple insulated wire, rated 130°C. (UR)
Bobbin of T1	Various	Various	PMC, V-0, 150°C, 0.45 mm thick min (cURus)
Insulated tape of T1	Various	Various	Polyethylene terephthalate film insulating tapes, yellow, rated 130°C, 0.025 mm thick per layer. Min. 2 layers are provided as outer wrap and between windings. (UR)
Varnish of T1	Various	Various	Rated 130°C. (UR)
TF Tube	Various	Various	Rated 300V, 200°C. (UR)

**WINDING(S) RESISTANCE**

Winding Designation	Wire Size (AWG or mm <sup>2</sup> )	Wire Type	Turns	Volts	Amps	DC resistance (Ω) +/- 10%:
N1	Φ0.2*1P	Magnetic wire	100	NA	NA	NA
N2	Φ0.27*1P	Triple insulated wire	70	NA	NA	NA
N3	Φ0.17*1P	Magnetic wire	38.5	NA	NA	NA

**VERIFICATION PROCESS**

Frequency: <b>Annual</b>	Test Site: <b>CEC</b>	Number of samples to test: <b>1</b>	
Test Name	Test Parameters		
Winding resistance	See resistance per winding above.		
Dielectric Strength	Apply voltage Between	Test Voltage	Test Time
	Primary to core	1240	1min
	Primary to secondary	1240	1min
	Secondary to core	1240	1min

**5.0 Critical Unlisted CEC Components**

**INSULATED COIL**

Photo #	Item no.	Name	Manufacturer/Trademark	Type / model
138	76	Transformer (T1)	Shenzhen goldsuno opto-electronic technology Co. Ltd.	TR018-B
Electrical Rating: 650uH.				Insulation class B
Component Standard used: UL 8750:2015 Ed.2+R:23Sep2021 CSA C22.2#250.13:2020 Ed.4+U1				

**MATERIALS LIST** (refer to illustration 40-41 for assembly drawing)

Component	Manufacturer	Type/model	Dimensions/thickness/assembly information
Insulation system	HANG SING INDUSTRIAL CO LTD	HSSBI4.2	Class B insulation system. (cURus)
Primary Winding of T2 (N1, N3, N4)	Various	2UEW	Polyurethane, rated 130°C min. (UR)
Secondary Winding of T2 (N2)	Various	TEX-E	Triple insulated wire, rated 130°C min. (UR)
Bobbin of T2	SUMITOMO BAKELITE CO LTD	PM-9820	PMC, V-0, 155°C, 0.75 mm thick min (cURus)
Insulated tape of T2	JINGJIANG YAHUA PRESSURE SENSITIVE GLUE CO LTD	CT-280B	Polyethylene terephthalate film insulating tapes, yellow, rated 130°C, 0.025 mm thick per layer. Min. 2 layers are provided as outer wrap and between windings. (UR)
Varnish of T2	SUZHOU TAIHU ELECTRIC ADVANCED MATERIAL CO LTD	T-4260(a)	Rated 130°C min. (UR)

**WINDING(S) RESISTANCE**

Winding Designation	Wire Size (AWG or mm <sup>2</sup> )	Wire Type	Turns	Volts	Amps	DC resistance (Ω) +/- 10%:
N1	Φ0.4*1P	Magnetic wire	60	NA	NA	NA
N2	Φ0.27*1P	Triple insulated wire	29	NA	NA	NA

**VERIFICATION PROCESS**

Frequency: <b>Annual</b>	Test Site: <b>CEC</b>	Number of samples to test: <b>1</b>	
Test Name	Test Parameters		
Winding resistance	See resistance per winding above.		
Dielectric Strength	Apply voltage Between	Test Voltage	Test Time
	Primary to core	1560	1min
	Primary to secondary	1560	1min
	Secondary to core	1560	1min

**5.0 Critical Unlisted CEC Components**

**INSULATED COIL**

Photo #	Item no.	Name	Manufacturer/Trademark	Type / model
140, 142	81	Transformer (T1)	Shenzhen goldsuno opto-electronic technology Co. Ltd.	DM001A
Electrical Rating: 400uH.				Insulation class B
Component Standard used: UL 8750:2015 Ed.2+R:23Sep2021 CSA C22.2#250.13:2020 Ed.4+U1				

**MATERIALS LIST** (refer to illustration 44-45 for assembly drawing)

Component	Manufacturer	Type/model	Dimensions/thickness/assembly information
Insulation system	HANG SING INDUSTRIAL CO LTD	HSSBI4.2	Class B insulation system. (cURus)
Primary Winding of T2 (N1, N3, N4)	Various	2UEW	Polyurethane, rated 130°C min. (UR)
Secondary Winding of T2 (N2)	Various	TEX-E	Triple insulated wire, rated 130°C min. (UR)
Bobbin of T2	SUMITOMO BAKELITE CO LTD	PM-9820	PMC, V-0, 155°C, 0.75 mm thick min (cURus)
Insulated tape of T2	JINGJIANG YAHUA PRESSURE SENSITIVE GLUE CO LTD	CT-280B	Polyethylene terephthalate film insulating tapes, yellow, rated 130°C, 0.025 mm thick per layer. Min. 2 layers are provided as outer wrap and between windings. (UR)
Varnish of T2	SUZHOU TAIHU ELECTRIC ADVANCED MATERIAL CO LTD	T-4260(a)	Rated 130°C min. (UR)

**WINDING(S) RESISTANCE**

Winding Designation	Wire Size (AWG or mm <sup>2</sup> )	Wire Type	Turns	Volts	Amps	DC resistance (Ω) +/- 10%:
N1	Φ0.27*1P	Magnetic wire	66	NA	NA	NA
N2	Φ0.5*1P	Triple insulated wire	22	NA	NA	NA
N3	Φ0.2*1P	Magnetic wire	15	NA	NA	NA

**VERIFICATION PROCESS**

Frequency: <b>Annual</b>	Test Site: <b>CEC</b>	Number of samples to test: <b>1</b>	
Test Name	Test Parameters		
Winding resistance	See resistance per winding above.		
Dielectric Strength	Apply voltage Between	Test Voltage	Test Time
	Primary to core	1560	1min
	Primary to secondary	1560	1min
	Secondary to core	1560	1min

**5.0 Critical Unlisted CEC Components**

**INSULATED COIL**

Photo #	Item no.	Name	Manufacturer/Trademark	Type / model
141, 142	81a	Transformer (T1)	Shenzhen goldsuno opto-electronic technology Co. Ltd.	DM001B
Electrical Rating: 400uH.				Insulation class B
Component Standard used: UL 8750:2015 Ed.2+R:23Sep2021 CSA C22.2#250.13:2020 Ed.4+U1				

**MATERIALS LIST** (refer to illustration 46-47 for assembly drawing)

Component	Manufacturer	Type/model	Dimensions/thickness/assembly information
Insulation system	HANG SING INDUSTRIAL CO LTD	HSSBI4.2	Class B insulation system. (cURus)
Primary Winding of T2 (N1, N3, N4)	Various	2UEW	Polyurethane, rated 130°C min. (UR)
Secondary Winding of T2 (N2)	Various	TEX-E	Triple insulated wire, rated 130°C min. (UR)
Bobbin of T2	SUMITOMO BAKELITE CO LTD	PM-9820	PMC, V-0, 155°C, 0.75 mm thick min (cURus)
Insulated tape of T2	JINGJIANG YAHUA PRESSURE SENSITIVE GLUE CO LTD	CT-280B	Polyethylene terephthalate film insulating tapes, yellow, rated 130°C, 0.025 mm thick per layer. Min. 2 layers are provided as outer wrap and between windings. (UR)
Varnish of T2	SUZHOU TAIHU ELECTRIC ADVANCED MATERIAL CO LTD	T-4260(a)	Rated 130°C min. (UR)

**WINDING(S) RESISTANCE**

Winding Designation	Wire Size (AWG or mm <sup>2</sup> )	Wire Type	Turns	Volts	Amps	DC resistance (Ω) +/- 10%:
N1	Φ0.27*1P	Magnetic wire	66	NA	NA	NA
N2	Φ0.5*1P	Triple insulated wire	22	NA	NA	NA
N3	Φ0.2*1P	Magnetic wire	15	NA	NA	NA

**VERIFICATION PROCESS**

Frequency: <b>Annual</b>	Test Site: <b>CEC</b>	Number of samples to test: <b>1</b>	
Test Name	Test Parameters		
Winding resistance	See resistance per winding above.		
Dielectric Strength	Apply voltage Between	Test Voltage	Test Time
	Primary to core	1560	1min
	Primary to secondary	1560	1min
	Secondary to core	1560	1min

**5.0 Critical Unlisted CEC Components**

**INSULATED COIL**

Photo #	Item no.	Name	Manufacturer/Trademark	Type / model
202	98d	Transformer (T1)	SHENZHEN JINHUADA ELECTRONICS CO., LTD.	TR-012B
Electrical Rating: 1.35mH				Insulation class B
Component Standard used: UL 8750:2015 Ed.2+R:23Sep2021 CSA C22.2#250.13:2020 Ed.4+U1				

**MATERIALS LIST** (refer to illustration 60 to 61 for assembly drawing)

Component	Manufacturer	Type/model	Dimensions/thickness/assembly information
Electrical Insulation System	HANG SING INDUSTRIAL CO LTD	HSSBI4.2	Class B insulation system. (cURus)
Primary Winding of T1 (N1,N3)	Various	2UEW	Polyurethane, rated 130°C. (UR)
Secondary Winding of T1 (N2)	Various	TILW -F2	Triple insulated wire, rated 130°C. (UR)
Bobbin of T1	Various	Various	PMC, V-0, 150°C, 0.8mm thick min (cURus)
Insulated tape of T1	Various	Various	Polyethylene terephthalate film insulating tapes, yellow, rated 130°C, 0.025 mm thick per layer. Min. 2 layers are provided as outer wrap and between windings. (UR)
Varnish of T1	Various	Various	Rated 130°C. (UR)
TF Tube	Various	Various	Rated 300V, 200°C. (UR)

**WINDING(S) RESISTANCE**

Winding Designation	Wire Size	Wire Type	Turns	Volts	Amps	DC resistance (Ω) +/- 10%:
N1(4-3)	Φ0.21mm*1P	Magnetic wire	60	NA	NA	NA
N2(6-7)	Φ0.25mm*1P	Triple insulated wire	50	NA	NA	NA
N3(3-5)	Φ0.21mm*1P	Magnetic wire	45	NA	NA	NA

**VERIFICATION PROCESS**

Frequency: <b>Annual</b>	Test Site: <b>CEC</b>	Number of samples to test: <b>1</b>	
Test Name	Test Parameters		
Winding resistance	See resistance per winding above.		
Dielectric Strength	Apply voltage Between	Test Voltage	Test Time
	Primary to core	1240Vac	1min
	Primary to secondary	1240Vac	1min
	Secondary to core	1240Vac	1min

**5.0 Critical Unlisted CEC Components**

**INSULATED COIL**

Photo #	Item no.	Name	Manufacturer/Trademark	Type / model
203, 220, 220a	99d	Transformer (T1)	SHENZHEN JINHUADA ELECTRONICS CO., LTD.	TR-019
Electrical Rating: 1.35mH			Insulation class B	
Component Standard used:			UL 8750:2015 Ed.2+R:23Sep2021 CSA C22.2#250.13:2020 Ed.4+U1	

**MATERIALS LIST** (refer to illustration 60 to 61 for assembly drawing)

Component	Manufacturer	Type/model	Dimensions/thickness/assembly information
Electrical Insulation System	HANG SING INDUSTRIAL CO LTD	HSSBI4.2	Class B insulation system. (cURus)
Primary Winding of T1 (N1,N3)	Various	2UEW	Polyurethane, rated 130°C. (UR)
Secondary Winding of T1 (N2)	Various	TILW -F2	Triple insulated wire, rated 130°C. (UR)
Bobbin of T1	Various	Various	PMC, V-0, 150°C, 0.8mm thick min (cURus)
Insulated tape of T1	Various	Various	Polyethylene terephthalate film insulating tapes, yellow, rated 130°C, 0.025 mm thick per layer. Min. 2 layers are provided as outer wrap and between windings. (UR)
Varnish of T1	Various	Various	Rated 130°C. (UR)
TF Tube	Various	Various	Rated 300V, 200°C. (UR)

**WINDING(S) RESISTANCE**

Winding Designation	Wire Size	Wire Type	Turns	Volts	Amps	DC resistance (Ω) +/- 10%:
N1(4-3)	Φ0.21mm*1P	Magnetic wire	60	NA	NA	NA
N2(6-7)	Φ0.25mm*1P	Triple insulated wire	50	NA	NA	NA
N3(3-5)	Φ0.21mm*1P	Magnetic wire	45	NA	NA	NA

**VERIFICATION PROCESS**

Frequency: <b>Annual</b>	Test Site: <b>CEC</b>	Number of samples to test: <b>1</b>	
Test Name	Test Parameters		
Winding resistance	See resistance per winding above.		
Dielectric Strength	Apply voltage Between	Test Voltage	Test Time
	Primary to core	1240Vac	1min
	Primary to secondary	1240Vac	1min
	Secondary to core	1240Vac	1min

**5.0 Critical Unlisted CEC Components**

**INSULATED COIL**

Photo #	Item no.	Name	Manufacturer/Trademark	Type / model
205	101d	Transformer (T1)	SHENZHEN JINHUADA ELECTRONICS CO., LTD.	TR023A
Electrical Rating: 1.1mH				Insulation class B
Component Standard used: UL 8750:2015 Ed.2+R:23Sep2021 CSA C22.2#250.13:2020 Ed.4+U1				

**MATERIALS LIST** (refer to illustration 66 to 67 for assembly drawing)

Component	Manufacturer	Type/model	Dimensions/thickness/assembly information
Electrical Insulation System	HANG SING INDUSTRIAL CO LTD	HSSBI4.2	Class B insulation system. (cURus)
Primary Winding of T1 (N1A,N3,N1B)	Various	2UEW	Polyurethane, rated 130°C. (UR)
Secondary Winding of T1 (N2)	Various	TILW -F2	Triple insulated wire, rated 130°C. (UR)
Bobbin of T1	Various	Various	PMC, V-0, 150°C, 0.8mm thick min (cURus)
Insulated tape of T1	Various	Various	Polyethylene terephthalate film insulating tapes, yellow, rated 130°C, 0.025 mm thick per layer. Min. 2 layers are provided as outer wrap and between windings. (UR)
Varnish of T1	Various	Various	Rated 130°C. (UR)
TF Tube	Various	Various	Rated 300V, 200°C. (UR)

**WINDING(S) RESISTANCE**

Winding Designation	Wire Size (AWG or mm <sup>2</sup> )	Wire Type	Turns	Volts	Amps	DC resistance (Ω) +/- 10%:
N1A	Φ0.21*1P	Magnetic wire	58	NA	NA	NA
N2	Φ0.25*1P	Triple insulated wire	45	NA	NA	NA
N1B	Φ0.21*1P	Magnetic wire	27	NA	NA	NA
N3	Φ0.18*1P	Magnetic wire	56	NA	NA	NA

**VERIFICATION PROCESS**

Frequency: <b>Annual</b>	Test Site: <b>CEC</b>	Number of samples to test: <b>1</b>	
Test Name	Test Parameters		
Winding resistance	See resistance per winding above.		
Dielectric Strength	Apply voltage Between	Test Voltage	Test Time
	Primary to core	1554Vac	1min
	Primary to secondary	1554Vac	1min
	Secondary to core	1554Vac	1min

**5.0 Critical Unlisted CEC Components**

**INSULATED COIL**

Photo #	Item no.	Name	Manufacturer/Trademark	Type / model
209	100d	Transformer (T1)	SHENZHEN JINHUADA ELECTRONICS CO., LTD.	TR018D
Electrical Rating: 0.75mH				Insulation class B
Component Standard used: UL 8750:2015 Ed.2+R:23Sep2021 CSA C22.2#250.13:2020 Ed.4+U1				

**MATERIALS LIST** (refer to illustration 70 to 71 for assembly drawing)

Component	Manufacturer	Type/model	Dimensions/thickness/assembly information
Electrical Insulation System	HANG SING INDUSTRIAL CO LTD	HSSBI4.2	Class B insulation system. (cURus)
Primary Winding of T1 (N1A,N1B)	Various	2UEW	Polyurethane, rated 130°C. (UR)
Secondary Winding of T1 (N2)	Various	TILW -F2	Triple insulated wire, rated 130°C. (UR)
Bobbin of T1	Various	Various	PMC, V-0, 150°C, 0.8mm thick min (cURus)
Insulated tape of T1	Various	Various	Polyethylene terephthalate film insulating tapes, yellow, rated 130°C, 0.025 mm thick per layer. Min. 2 layers are provided as outer wrap and between windings. (UR)
Varnish of T1	Various	Various	Rated 130°C. (UR)
TF Tube	Various	Various	Rated 300V, 200°C. (UR)

**WINDING(S) RESISTANCE**

Winding Designation	Wire Size	Wire Type	Turns	Volts	Amps	DC resistance (Ω) +/- 10%:
N1A	Φ0.3mm*1P	Magnetic wire	50	NA	NA	NA
N2	Φ0.25mm*1P	Triple insulated wire	50	NA	NA	NA
N1B	Φ0.3mm*1P	Magnetic wire	5	NA	NA	NA

**VERIFICATION PROCESS**

Frequency: <b>Annual</b>	Test Site: <b>CEC</b>	Number of samples to test: <b>1</b>	
Test Name	Test Parameters		
Winding resistance	See resistance per winding above.		
Dielectric Strength	Apply voltage Between	Test Voltage	Test Time
	Primary to core	1554Vac	1min
	Primary to secondary	1554Vac	1min
	Secondary to core	1554Vac	1min

**5.0 Critical Unlisted CEC Components**

**INSULATED COIL**

Photo #	Item no.	Name	Manufacturer/Trademark	Type / model
204	104d	Transformer (T1)	SHENZHEN JINHUADA ELECTRONICS CO., LTD.	TR030
Electrical Rating: 0.75-0.8mH				Insulation class B
Component Standard used: UL 8750:2015 Ed.2+R:23Sep2021 CSA C22.2#250.13:2020 Ed.4+U1				

**MATERIALS LIST** (refer to illustration 74 to 75 for assembly drawing)

Component	Manufacturer	Type/model	Dimensions/thickness/assembly information
Electrical Insulation System	HANG SING INDUSTRIAL CO LTD	HSSBI4.2	Class B insulation system. (cURus)
Primary Winding of T1 (N1,N3)	Various	2UEW	Polyurethane, rated 130°C. (UR)
Secondary Winding of T1 (N2)	Various	TILW -F2	Triple insulated wire, rated 130°C. (UR)
Bobbin of T1	Various	Various	PMC, V-0, 150°C, 0.8mm thick min (cURus)
Insulated tape of T1	Various	Various	Polyethylene terephthalate film insulating tapes, yellow, rated 130°C, 0.025 mm thick per layer. Min. 2 layers are provided as outer wrap and between windings. (UR)
Varnish of T1	Various	Various	Rated 130°C. (UR)
TF Tube	Various	Various	Rated 300V, 200°C. (UR)

**WINDING(S) RESISTANCE**

Winding Designation	Wire Size	Wire Type	Turns	Volts	Amps	DC resistance (Ω) +/- 10%:
N1	Φ0.27mm*1P	Magnetic wire	40	NA	NA	NA
N2	Φ0.4mm*1P	Triple insulated wire	54	NA	NA	NA
N3	Φ0.27mm*1P	Magnetic wire	46	NA	NA	NA

**VERIFICATION PROCESS**

Frequency: <b>Annual</b>	Test Site: <b>CEC</b>	Number of samples to test: <b>1</b>	
Test Name	Test Parameters		
Winding resistance	See resistance per winding above.		
Dielectric Strength	Apply voltage Between	Test Voltage	Test Time
	Primary to core	1240Vac	1min
	Primary to secondary	1240Vac	1min
	Secondary to core	1240Vac	1min

**5.0 Critical Unlisted CEC Components**

**INSULATED COIL**

Photo #	Item no.	Name	Manufacturer/Trademark	Type / model
207, 221, 221a	106d	Transformer (T1)	SHENZHEN JINHUADA ELECTRONICS CO., LTD.	TR031A
Electrical Rating: 0.7mH				Insulation class B
Component Standard used: UL 8750:2015 Ed.2+R:23Sep2021 CSA C22.2#250.13:2020 Ed.4+U1				

**MATERIALS LIST** (refer to illustration 84a for assembly drawing)

Component	Manufacturer	Type/model	Dimensions/thickness/assembly information
Electrical Insulation System	HANG SING INDUSTRIAL CO LTD	HSSBI4.2	Class B insulation system. (cURus)
Primary Winding of T1 (N1,N3)	Various	2UEW	Polyurethane, rated 130°C. (UR)
Secondary Winding of T1 (N2)	Various	TILW -F2	Triple insulated wire, rated 130°C. (UR)
Bobbin of T1	Various	Various	PMC, V-0, 150°C, 0.8mm thick min (cURus)
Insulated tape of T1	Various	Various	Polyethylene terephthalate film insulating tapes, yellow, rated 130°C, 0.025 mm thick per layer. Min. 2 layers are provided as outer wrap and between windings. (UR)
Varnish of T1	Various	Various	Rated 130°C. (UR)
TF Tube	Various	Various	Rated 300V, 200°C. (UR)

**WINDING(S) RESISTANCE**

Winding Designation	Wire Size (AWG or mm <sup>2</sup> )	Wire Type	Turns	Volts	Amps	DC resistance (Ω) +/- 10%:
N1	Φ0.35*1P	Magnetic wire	38	NA	NA	NA
N2	Φ0.3*2P	Triple insulated wire	22	NA	NA	NA
N3	Φ0.35*1P	Magnetic wire	16	NA	NA	NA

**VERIFICATION PROCESS**

Frequency: <b>Annual</b>	Test Site: <b>CEC</b>	Number of samples to test: <b>1</b>	
Test Name	Test Parameters		
Winding resistance	See resistance per winding above.		
Dielectric Strength	Apply voltage Between	Test Voltage	Test Time
	Primary to core	1554Vac	1min
	Primary to secondary	1554Vac	1min
	Secondary to core	1554Vac	1min

5.0 Critical Unlisted CEC Components				
SUBASSEMBLY				
Photo #	Item no.	Name	Manufacturer/Trademark	Type / model
216	133	LED Driver-21	Shenzhen goldsuno opto-electronic technology Co. Ltd.	TR120A
Electrical Rating:			Input: 120V, 60Hz, Max.8W Output: 21-30Vdc, 0.26A	Insulation class B
Component Standard used:			UL 8750:2015 Ed.2+R:23Sep2021 CSA C22.2#250.13:2020 Ed.4+U1	

COMPONENTS LIST									
Photo #	Item no.	Photo #	Item no.	Photo #	Item no.	Photo #	Item no.	Photo #	Item no.
216	134	216	135	216	136	216	137	216	138
216	139	216	140	216	141	217	142		

VERIFICATION PROCESS		
Test Name	Test Parameters	
Frequency: <b>Annual</b>	Test Site: <b>CEC</b>	Number of samples to test: <b>1</b>
Verify Construction	Per the component descriptions noted above	

SUBASSEMBLY				
Photo #	Item no.	Name	Manufacturer/Trademark	Type / model
216a	133a	LED Driver-22	Shenzhen goldsuno opto-electronic technology Co. Ltd.	TR120B
Electrical Rating:			Input: 120V, 60Hz, Max.12W Output: 21-36Vdc, 0.26A	Insulation class B
Component Standard used:			UL 8750:2015 Ed.2+R:23Sep2021 CSA C22.2#250.13:2020 Ed.4+U1	

COMPONENTS LIST									
Photo #	Item no.	Photo #	Item no.	Photo #	Item no.	Photo #	Item no.	Photo #	Item no.
216a	134	216a	135	216a	136	216a	137	216a	138
216a	140	216a	141	217	142	216a	143		

VERIFICATION PROCESS		
Test Name	Test Parameters	
Frequency: <b>Annual</b>	Test Site: <b>CEC</b>	Number of samples to test: <b>1</b>
Verify Construction	Per the component descriptions noted above	

5.0 Critical Unlisted CEC Components				
SUBASSEMBLY				
Photo #	Item no.	Name	Manufacturer/Trademark	Type / model
277	172	LED Driver-23	Shenzhen goldsuno opto-electronic technology Co. Ltd.	TR-125
Electrical Rating:			Input: 120V, 60Hz, Max.12W Output: 21-40Vdc, 0.29A	Insulation class B
Component Standard used:			UL 8750:2015 Ed.2+R:23Sep2021 CSA C22.2#250.13:2020 Ed.4+U1	

COMPONENTS LIST									
Photo #	Item no.	Photo #	Item no.	Photo #	Item no.	Photo #	Item no.	Photo #	Item no.
277	173	277	174	277	175	277	176	277	177
277	178	277	179						

VERIFICATION PROCESS			
Test Name	Test Parameters		
Frequency: <b>Annual</b>	Test Site: <b>CEC</b>	Number of samples to test: <b>1</b>	
Verify Construction	Per the component descriptions noted above		

SUBASSEMBLY				
Photo #	Item no.	Name	Manufacturer/Trademark	Type / model
282	183	LED Driver-24	Shenzhen goldsuno opto-electronic technology Co. Ltd.	TR-053
Electrical Rating:			Input: 120V, 60Hz, Max.10W Output: 25-27Vdc, 0.24A	Insulation class B
Component Standard used:			UL 8750:2015 Ed.2+R:23Sep2021 CSA C22.2#250.13:2020 Ed.4+U1	

COMPONENTS LIST									
Photo #	Item no.	Photo #	Item no.	Photo #	Item no.	Photo #	Item no.	Photo #	Item no.
282	184	282	185	282	186	282	187	282	188
283	189								

VERIFICATION PROCESS			
Test Name	Test Parameters		
Frequency: <b>Annual</b>	Test Site: <b>CEC</b>	Number of samples to test: <b>1</b>	
Verify Construction	Per the component descriptions noted above		

5.0 Critical Unlisted CEC Components				
SUBASSEMBLY				
Photo #	Item no.	Name	Manufacturer/Trademark	Type / model
282	183a	LED Driver-25	Shenzhen goldsuno opto-electronic technology Co. Ltd.	TR-054
Electrical Rating:			Input: 120V, 60Hz, Max.12W Output: 25-36Vdc, 0.24A	Insulation class B
Component Standard used:			UL 8750:2015 Ed.2+R:23Sep2021 CSA C22.2#250.13:2020 Ed.4+U1	

COMPONENTS LIST									
Photo #	Item no.	Photo #	Item no.	Photo #	Item no.	Photo #	Item no.	Photo #	Item no.
282	184	282	185	282	186a	282	187	282	188
283	189								

VERIFICATION PROCESS		
Test Name	Test Parameters	
Frequency: <b>Annual</b>	Test Site: <b>CEC</b>	Number of samples to test: <b>1</b>
Verify Construction	Per the component descriptions noted above	

SUBASSEMBLY				
Photo #	Item no.	Name	Manufacturer/Trademark	Type / model
278a	172a	LED Driver-26	Shenzhen goldsuno opto-electronic technology Co. Ltd.	TR-063
Electrical Rating:			Input: 120V, 60Hz, Max. 12W. Output: 21-40Vdc, 0.29A.	Insulation class B
Component Standard used:			UL 8750:2015 Ed.2+R:23Sep2021 CSA C22.2#250.13:2020 Ed.4+U1	

COMPONENTS LIST									
Photo #	Item no.	Photo #	Item no.	Photo #	Item no.	Photo #	Item no.	Photo #	Item no.
278a	173	278a	175	278a	176	278a	177	278a	178
278a	179	278a	173a						

VERIFICATION PROCESS		
Test Name	Test Parameters	
Frequency: <b>Annual</b>	Test Site: <b>CEC</b>	Number of samples to test: <b>1</b>
Verify Construction	Per the component descriptions noted above	

5.0 Critical Unlisted CEC Components				
SUBASSEMBLY				
Photo #	Item no.	Name	Manufacturer/Trademark	Type / model
293, 297	212	LED Driver-27	Shenzhen goldsuno opto-electronic technology Co. Ltd.	TR-319
Electrical Rating:			Input: 120V, 60Hz, Max. 12W. Output: 30-40Vdc, 0.29A	Insulation class NA
Component Standard used:			UL 8750:2015 Ed.2+R:23Sep2021 CSA C22.2#250.13:2020 Ed.4+U1	

COMPONENTS LIST									
Photo #	Item no.	Photo #	Item no.	Photo #	Item no.	Photo #	Item no.	Photo #	Item no.
297	213	297	214	297	215	297	216		

VERIFICATION PROCESS			
Test Name	Test Parameters		
Frequency: <b>Annual</b>	Test Site: <b>CEC</b>	Number of samples to test: <b>1</b>	
Verify Construction	Per the component descriptions noted above		

SUBASSEMBLY				
Photo #	Item no.	Name	Manufacturer/Trademark	Type / model
332, 333	246	LED Driver-28	Shenzhen goldsuno opto-electronic technology Co. Ltd.	TR-062
Electrical Rating:			Phase cut type dimming. LVLE output, Input: 120V, 60Hz, Max. 18W. Output: 42-58Vdc, 0.27A.	Insulation class B
Component Standard used:			UL 8750:2015 Ed.2+R:23Sep2021 CSA C22.2#250.13:2020 Ed.4+U1	

COMPONENTS LIST (refer to illustration _ for assembly drawing)									
Photo #	Item no.	Photo #	Item no.	Photo #	Item no.	Photo #	Item no.	Photo #	Item no.
332	247	332	248	332	249	332	250	332	251
333	252	332	263						

VERIFICATION PROCESS			
Test Name	Test Parameters		
Frequency: <b>Annual</b>	Test Site: <b>CEC</b>	Number of samples to test: <b>1</b>	
Verify Construction	Per the component descriptions noted above		

5.0 Critical Unlisted CEC Components				
SUBASSEMBLY				
Photo #	Item no.	Name	Manufacturer/Trademark	Type / model
334, 335	253	LED Driver-29	Shenzhen goldsuno opto-electronic technology Co. Ltd.	TR-054B
Electrical Rating: LVLE output, Provide with WIFI dimming function. Input: 100-277V, 50/60Hz, Max. 12W. Output: 30-40Vdc, 0.27A.				Insulation class NA
Component Standard used: UL 8750:2015 Ed.2+R:23Sep2021 CSA C22.2#250.13:2020 Ed.4+U1				

COMPONENTS LIST									
Photo #	Item no.	Photo #	Item no.	Photo #	Item no.	Photo #	Item no.	Photo #	Item no.
334	254	334	255	334	256	334	257	335	258

VERIFICATION PROCESS			
Test Name	Test Parameters		
Frequency: <b>Annual</b>	Test Site: <b>CEC</b>	Number of samples to test: <b>1</b>	
Verify Construction	Per the component descriptions noted above		

SUBASSEMBLY				
Photo #	Item no.	Name	Manufacturer/Trademark	Type / model
339, 340	258	LED Driver-30	Shenzhen goldsuno opto-electronic technology Co. Ltd.	TR-071
Electrical Rating: LVLE output, phase cut type dimming. Input: 120V, 60Hz, Max. 10W. Output: 30-42Vdc, 0.21A.				Insulation class NA
Component Standard used: UL 8750:2015 Ed.2+R:23Sep2021 CSA C22.2#250.13:2020 Ed.4+U1				

COMPONENTS LIST									
Photo #	Item no.	Photo #	Item no.	Photo #	Item no.	Photo #	Item no.	Photo #	Item no.
339	259	339	260	336	261	340	262	339	263

VERIFICATION PROCESS			
Test Name	Test Parameters		
Frequency: <b>Annual</b>	Test Site: <b>CEC</b>	Number of samples to test: <b>1</b>	
Verify Construction	Per the component descriptions noted above		

## 6.0 Critical Features

Recognized Component - A component part, which has been previously evaluated by an accredited certification body with restrictions and must be evaluated as part of the basic product considering the restrictions as specified by the Conditions of Acceptability.

Listed Component - A component part, which has been previously Listed or Certified by an accredited Certification Organization with no restrictions and is used in the intended application within its ratings.

Unlisted Component - A part that has not been previously evaluated to the appropriate designated component standard. It may also be a Listed or Recognized component that is being used outside of its evaluated Listing or component recognition.

Critical Features/Components - An essential part, material, subassembly, system, software, or accessory of a product that has a direct bearing on the product's conformance to applicable requirements of the product standard.

Construction Details - For specific construction details, reference should be made to the photographs and descriptions. All dimensions are approximate unless specified as exact or within a tolerance. In addition to the specific construction details described in this Report, the following general requirements also apply.

1. Spacing - In primary circuits, 3.2 mm minimum spacing are maintained through air and over surfaces of insulating material between current-carrying parts of opposite polarity and 6.4 mm minimum between such current-carrying parts and dead-metal parts or low voltage isolated circuits.
2. Mechanical Assembly - Components such as switches, fuseholders, connectors, wiring terminals and display lamps are mounted and prevented from shifting or rotating by the use of lockwashers, starwashers, or other mounting format that prevents turning of the component.
3. Corrosion Protection - All ferrous metal parts are protected against corrosion by painting, plating or the equivalent.
4. Accessibility of Live Parts - All uninsulated live parts in primary circuitry are housed within a metal enclosure constructed with no openings other than those specifically described in Sections 4 and 5.
5. Grounding - All exposed dead-metal parts and all dead-metal parts within the enclosure that are exposed are connected to the grounding lead of 18AWG conductor and minimum 150mm extending beyond junction box.
6. Polarized Connection - This product is provided with a polarized power supply connection. All single pole switches and fuses are connected only to the ungrounded supply circuit conductor.
7. Internal Wiring - Internal wiring is routed away from sharp or moving parts. Internal wiring leads terminating in soldered connections are made mechanically secure prior to soldering. Recognized Component separable (quick disconnect) connectors of the positive detent type, closed loop connectors, or other types specifically described in the text of this report are also acceptable as internal wiring terminals. At points where internal wiring passes through metal walls or partitions, the wiring insulation is protected against abrasion or damage by plastic bushings or grommets.
8. Schematics - Refer to Illustration No(s). 3,4,24,25,58,62,64,68,72,81a,85,92,93a,95,99,102,105,108 for schematics requiring verification during Field Representative Inspection Audits.
9. Markings - The product is marked on a labeling system of Section 4.0 (item 43,122,205,264) as follows: (Refer to Illustration 1 for format designation of marking, and Illustration 2 for marking sample.)
  1. Certification Mark as authorized in the Authorization to Mark
  2. Applicant Name or Brand Name (S16-L2)
  3. Model number (S16-L2)
  4. Date code of at least the month and year of manufacture (S16-L2)
  5. Input rating in volts(V), hertz(HZ), and total amperes(A) or watts(W) (S16-L3)

## 6.0 Critical Features

10. Cautionary Markings - The following are required as below:  
(Refer to Illustration 1 for format designation of marking, and Illustration 2 for marking sample.)
1. **"MIN 90 °C SUPPLY CONDUCTORS" & "LES FILS D'ALIMENTATION 90°C MIN"** (Verbatim, S16-L3)
  2. **ACCESS ABOVE CEILING REQUIRED** and **"ACCÈS REQUIS AU-DESSUS DU PLAFOND"** (Verbatim, S16-L2)
  3. **"TYPE IC"** and **"TYPE IC"** (S16-L3)
  4. **"INHERENTLY PROTECTED"** and **"PROTECTION INHÉRENTE"** (S16-L3)
  5. **"VAPOR BARRIER MUST BE SUITABLE FOR 90 °C"** and **"LE PARE-VAPEUR DOIT CONVENIR POUR 90 °C"** (S16-L2)
  6. **"SUITABLE FOR DAMP LOCATIONS" & "CONVIENT AUX EMPLACEMENTS HUMIDES"** (S16-L2, Verbatim)
  7. Recessed luminaires employing unenclosed appliance wiring material, as permitted by Clauses 6.10.3(b)(2) – 6.10.3(b)(4)  
**"FOR USE IN NON-FIRE-RATED INSTALLATIONS ONLY" & "UTILISER SEULEMENT DANS DES INSTALLATIONS OÙ LE DEGRÉ DE RÉSISTANCE AU FEU N'EST PAS ÉTABLI"** (S16-L2)
11. Installation, Operating and Safety Instructions - Instructions for installation and use of this product are provided by the manufacturer.  
The instruction manual shall contained the following information: (S16-L5)
1. **INSTALLATION OR ASSEMBLY INSTRUCTIONS**
    - a. Wiring instructions that specify the proper method of connecting the grounding means and maintaining polarity shall be included with the luminaire in a manner that will require the installer to handle the instructions during installation.
    - b. Specification of mounting hardware shall be included in the instruction sheet.
    - c. Other warnings that will not lead to misuse.
12. Transformer - Supplier records must be provided that indicate the received shipment of transformers was constructed as indicated in Section 4.0 item 139, 143, 176, 186, 186a, 215, 250, 256, 260. These records must be available at the factory for inspection on every received shipment.

**7.0 Illustrations**

**Illustration 1 - Format Designation of Markings and Instructions**

The table of the format minimum size designation (S\_\_\_) for marking height and typeface is at below:

Size Designation	Letter Height		Font Size	Font typeface, upper case
	( mm )	( in )	(points)	
S16	1.6	0.062	6	Univers bold, Arial bold, Helvetica bold, Zurich BT bold
S24	2.4	0.094	10	Univers bold, Arial bold, Helvetica bold, Zurich BT bold
S32	3.2	0.125	12	Not specified
S48	4.8	0.188	19	Univers bold, Arial bold, Helvetica bold, Zurich BT Bold

The table of the format location designation (L\_\_\_) for marking is at below:

Location Designation	Description	Label exposed to a dry/damp environment	Label exposed to a wet environment
L1	Visible during relamping, after installation	Type P	Type P
L2	Visible during installation	Type N	Type P
L3	Visible during installation and inspection of wire connections, located near the supply connections	Type N	Type P
L4	On the smallest unit package or carton	Type T	Type T
L5	On an instruction sheet or tag, or manufacturers website	Type T	Type T
L6	Visible during component replacement	Type P	Type P

Type P designates a permanent label or nameplate that is intended to remain in the applied position for the lifetime of the luminaire under conditions of normal use. It provides information required for user maintenance over the expected life of the product. It is made of metal, plastic, or other material that complies with Clause 20.1.7.

Type N designates a non-permanent label or nameplate that is intended to remain in place only for the purpose of installation. It shows the certification mark, manufacturer's identification, and product identification. It is made of paper with an adhesive backing.

Type T designates a temporary label, instruction sheet, or tag that is not required after installation. It provides installation instructions, and information not required after installation. It is made of printed matter with or without adhesive and/or attachment, and is intended to be included with, or attached to, the product, or designates a publicly accessible website.

## 7.0 Illustrations

### Illustration 2 - Markings sample

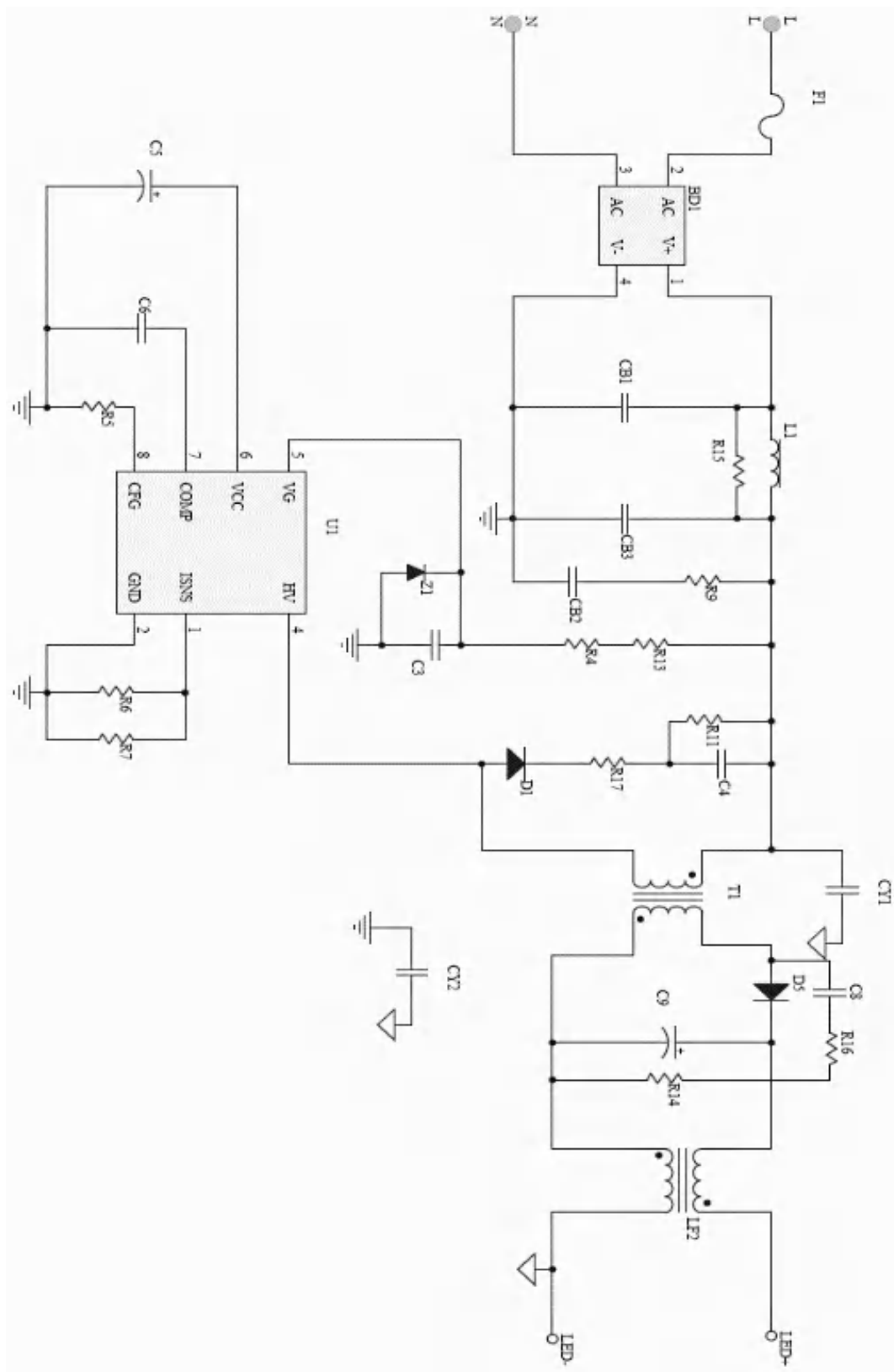


#### Remark:

1. Date code in form of MMYT where MM is month and YY is year.
2. Other text is at least 1.3 mm (0.05 in) high and contrasting in color to the background.
3. Other models (ref. Sec 2.0) have similar labels except the electrical specification and model name.

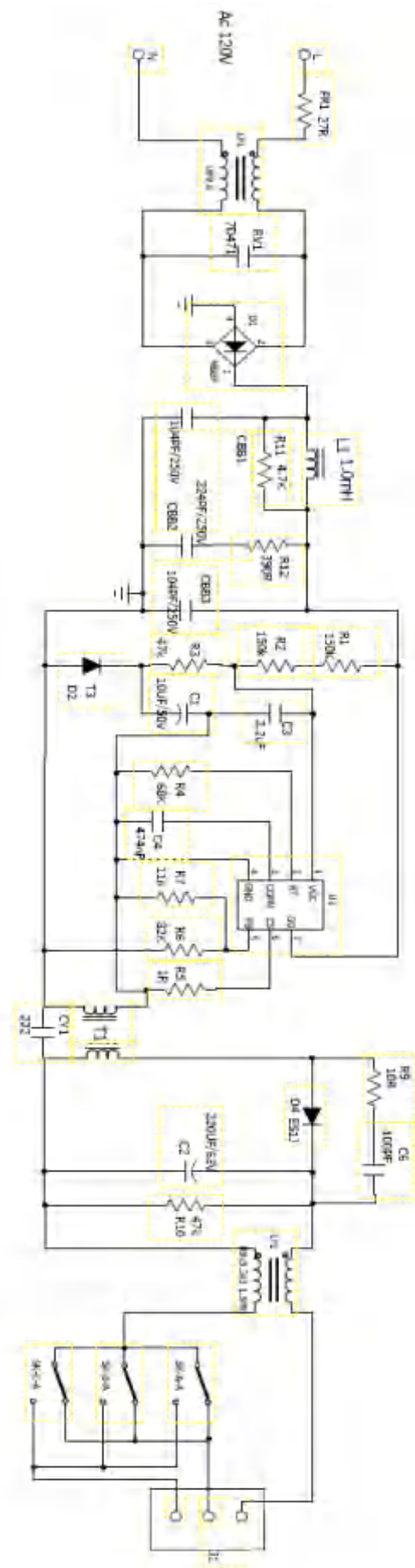
**7.0 Illustrations**

**Illustration 3** - Schematics of driver PCB of models JXL-COB03-T07W-UDD-xx, JXL-COB03-T10W-UDD-xx, JXL-COB04-T10W-UDD-xx, JXL-COF04-T10W-UDD-xx



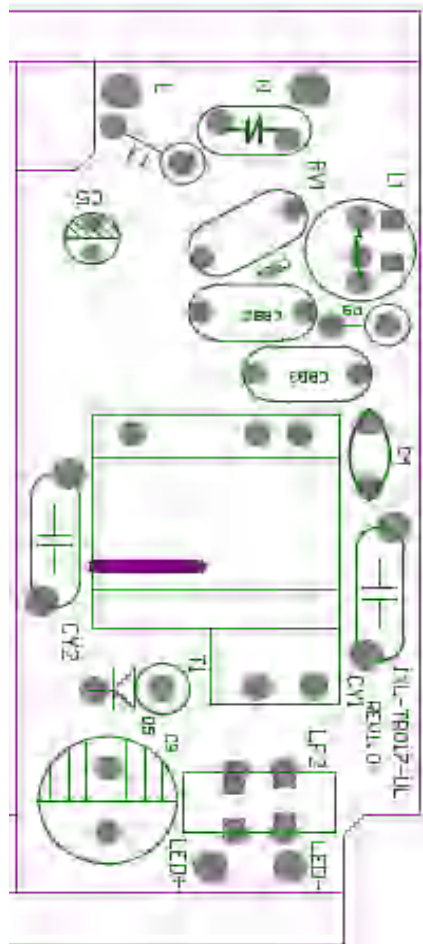
**7.0 Illustrations**

**Illustration 4** - Schematics of driver PCB of models JXL-TZ04-T10W-CCT-xx and JXL-TZ06-T12W-CCT-xx



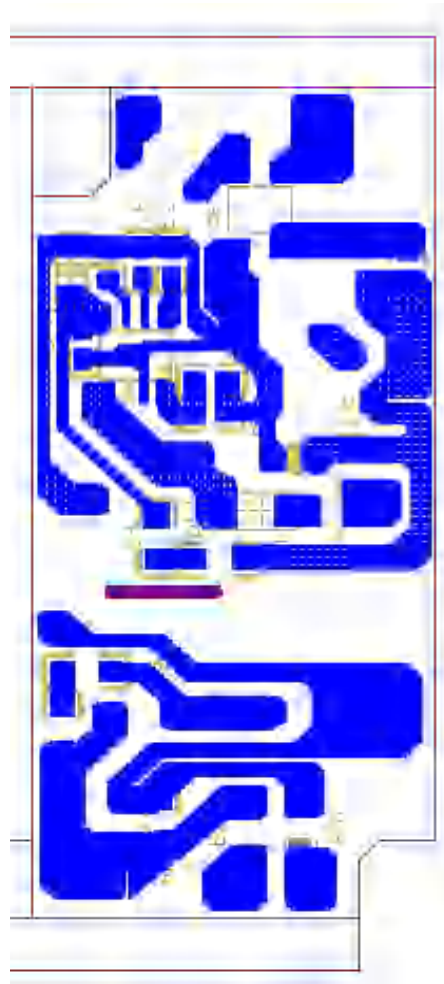
**7.0 Illustrations**

**Illustration 6** - Top PCB layout of driver of models JXL-COB03-T07W-UDD-xx, JXL-COB03-T10W-UDD-xx, JXL-COB04-T10W-UDD-xx, JXL-COF04-T10W-UDD-xx



## 7.0 Illustrations

**Illustration 7** - Bottom PCB layout of driver of models JXL-COB03-T07W-UDD-xx, JXL-COB03-T10W-UDD-xx, JXL-COB04-T10W-UDD-xx, JXL-COF04-T10W-UDD-xx



**7.0 Illustrations**

**Illustration 8** - Top PCB layout of driver of models JXL-TZ04-T10W-CCT-xx and JXL-TZ06-T12W-CCT-xx



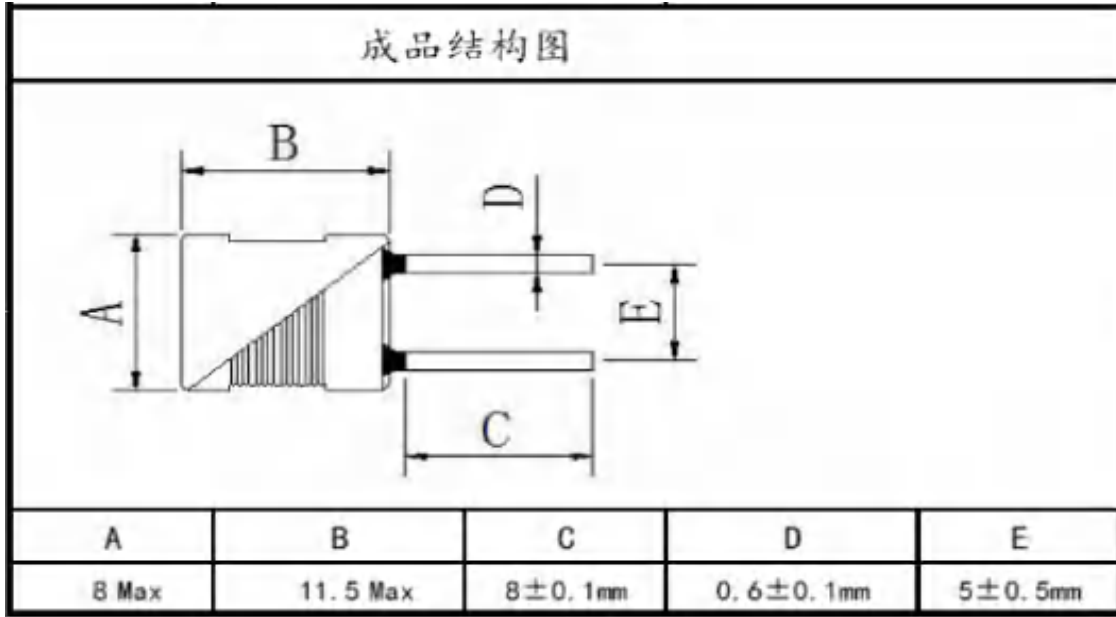
**7.0 Illustrations**

**Illustration 9** - Bottom PCB layout of driver of models JXL-TZ04-T10W-CCT-xx and JXL-TZ06-T12W-CCT-xx



**7.0 Illustrations**

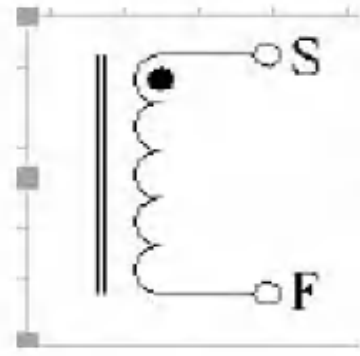
**Illustration 11** - Specification of inductor(L1) for models JXL-COB03-T07W-UDD-xx, JXL-COB03-T10W-UDD-xx, JXL-COB04-T10W-UDD-xx, JXL-COF04-T10W-UDD-xx



**7.0 Illustrations**

**Illustration 12** - Specification of inductor(L1) for models JXL-COB03-T07W-UDD-xx, JXL-COB03-T10W-UDD-xx, JXL-COB04-T10W-UDD-xx, JXL-COF04-T10W-UDD-xx

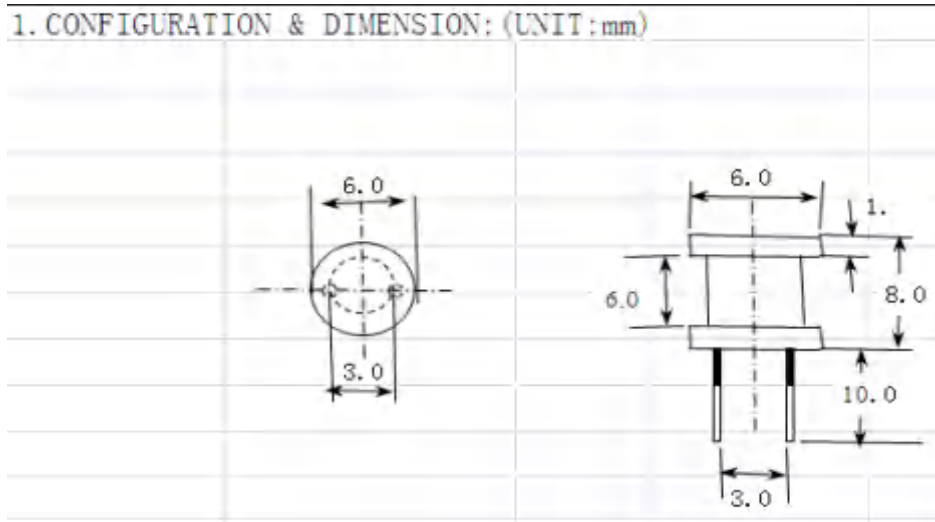
4. 电性图



0. 15\*1P\*415TS

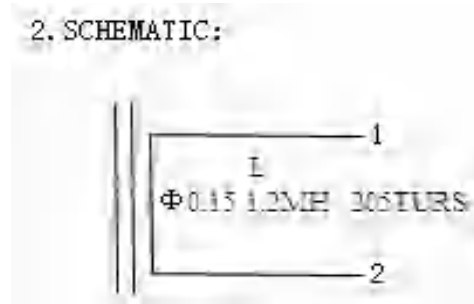
**7.0 Illustrations**

**Illustration 13** - Specification of inductor(L1) for models JXL-TZ04-T10W-CCT-xx, JXL-TZ06-T12W-CCT-xx



## 7.0 Illustrations

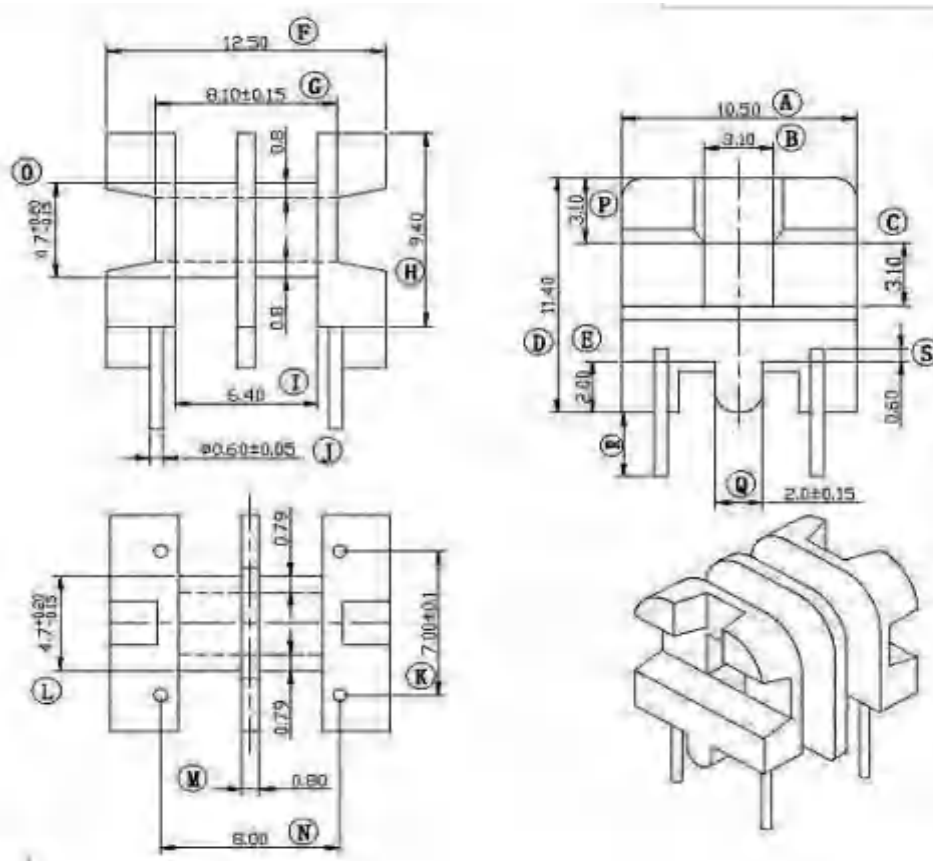
**Illustration 14** - Specification of inductor(L1) for models JXL-TZ04-T10W-CCT-xx, JXL-TZ06-T12W-CCT-xx



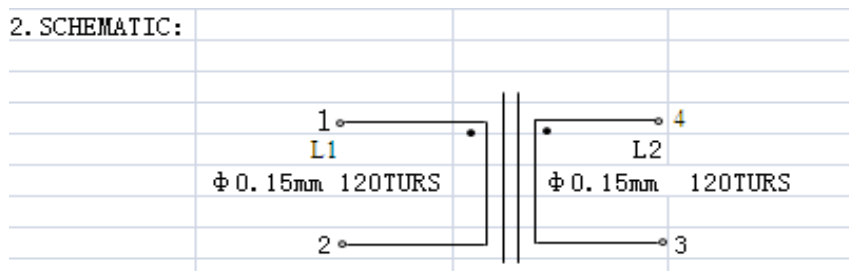
**7.0 Illustrations**

**Illustration 15** - Specification of inductor(LF1) for models JXL-TZ04-T10W-CCT-xx, JXL-TZ06-T12W-CCT-xx

1. 机械制图 DIMENSION: (UNIT:mm)



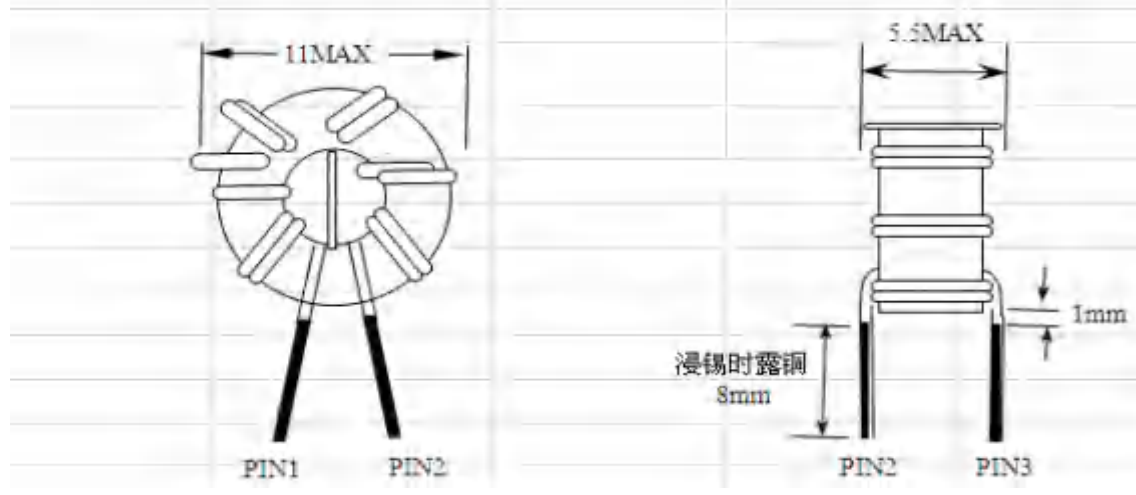
2. SCHEMATIC:



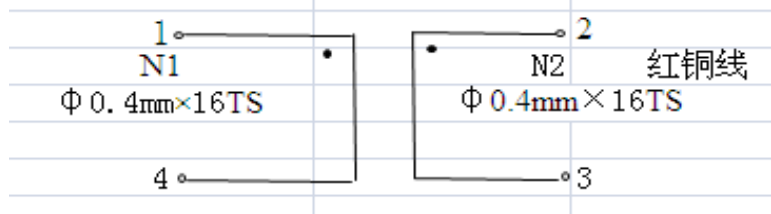
**7.0 Illustrations**

**Illustration 16** - Specification of inductor(LF2) for models JXL-TZ04-T10W-CCT-xx, JXL-TZ06-T12W-CCT-xx

1. 机械制图 DIMENSION: (UNIT:mm)



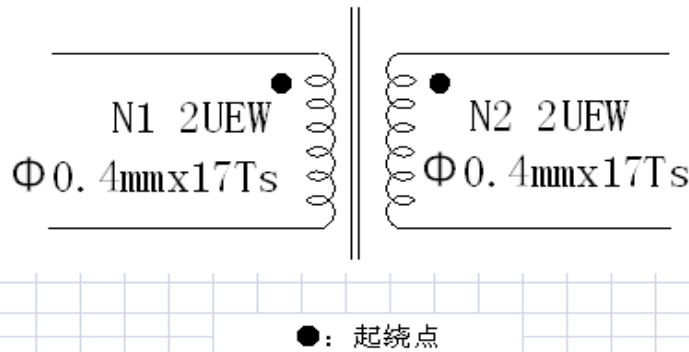
2. SCHEMATIC:



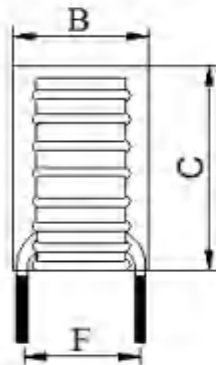
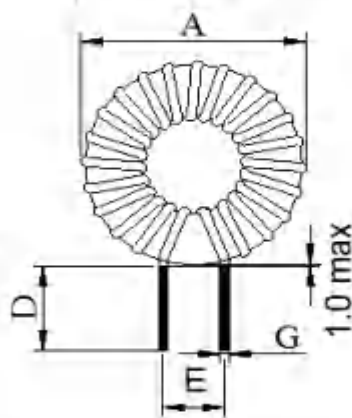
**7.0 Illustrations**

**Illustration 17 -** Specification of inductor(LF2) for models JXL-COB03-T07W-UDD-xx, JXL-COB03-T10W-UDD-xx, JXL-COB04-T10W-UDD-xx, JXL-COF04-T10W-UDD-xx

二、线路图SCHEMATIC:



一、外观尺寸图PHYSICAL DIMENSION (UNIT: mm)



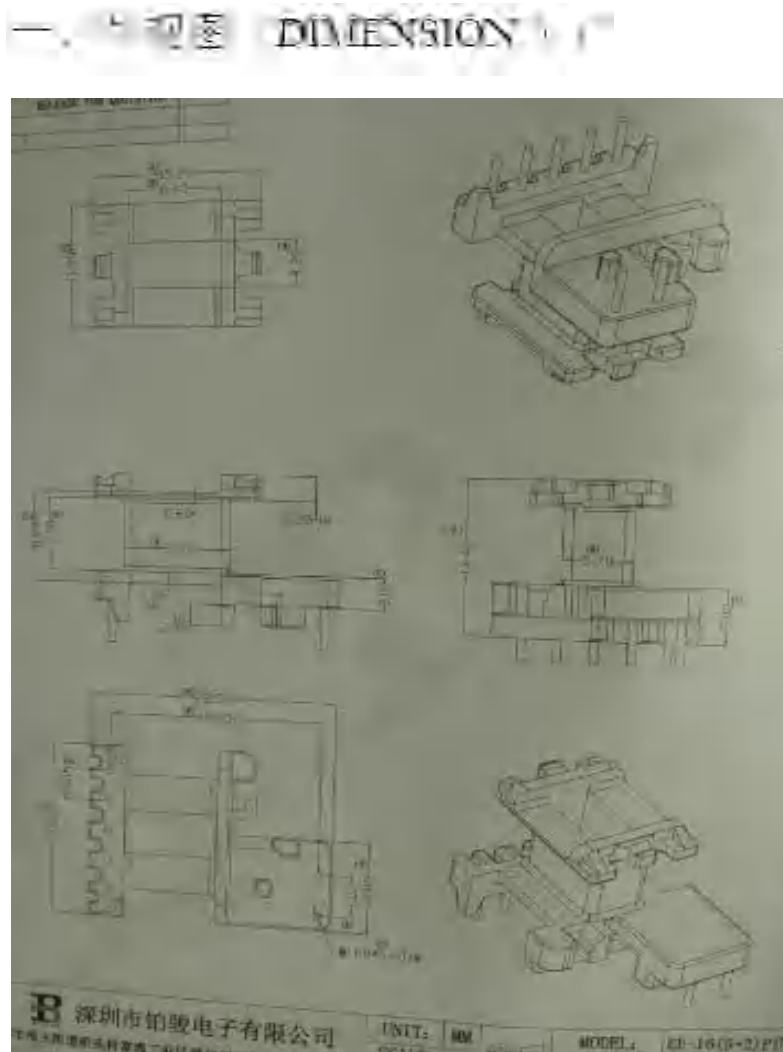
A	11 Max
B	5.5 Max
C	10.5 Max
D	8 ± 1mm
E	4Ref
F	4.5Ref
G	0.4mm
H	

三、绕线结构WINDING TABLE:

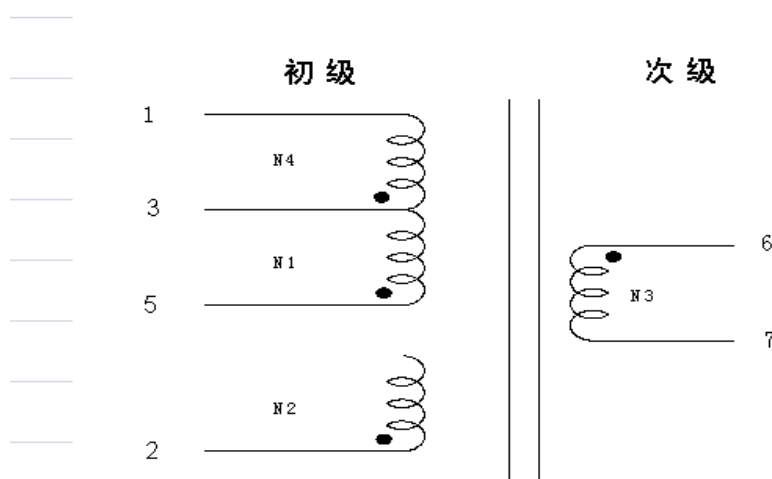
绕组 WINDING No	档墙胶带 MARGIN TAPE	脚位 PIN	线径&铜带+股数&宽度 WIRE DIAMETER& COPPER	圈数 TURNS	绕线方式 WINDIGN TYPE
N1		1-2	2UEW-N Φ0.4*1F	17TS	双线并绕
N2		3-4	2UEW-R Φ0.4*1F	17TS	

**7.0 Illustrations**

**Illustration 18** - Specification of transformer(T1) of TR017 for models JXL-COB03-T07W-UDD-xx, JXL-COB03-T10W-UDD-xx, JXL-COB04-T10W-UDD-xx, JXL-COF04-T10W-UDD-xx



**二、电器原理图 (CIRCUIT DIAGRAM) :**



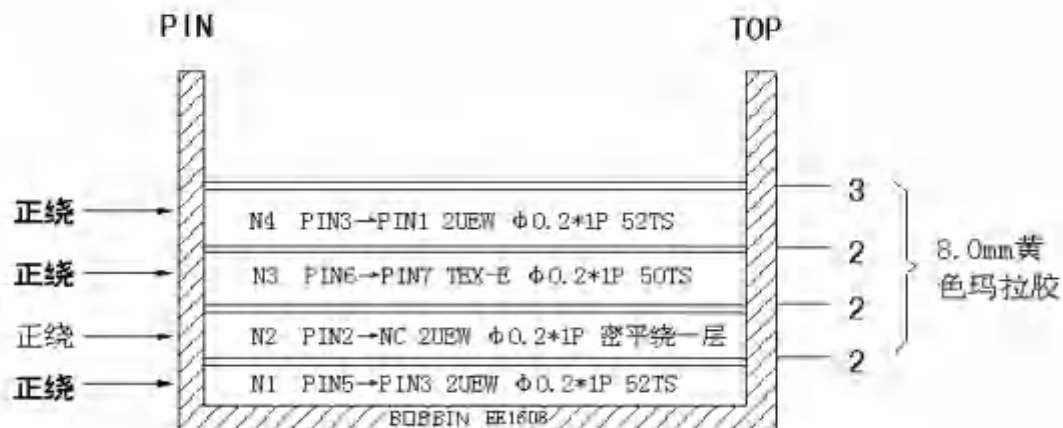
**7.0 Illustrations**

**Illustration 19** - Specification of transformer(T1) of TR017 for models JXL-COB03-T07W-UDD-xx, JXL-COB03-T10W-UDD-xx, JXL-COB04-T10W-UDD-xx, JXL-COF04-T10W-UDD-xx (Cont'd)

四、绕线表WINDING:

序号 NO.	起头 START	收尾 FINISH	圈数 TURNS	漆包线 WIRE	挡墙、胶带圈数规格 MARGIN, TAPE TURNS				绕制 方式 WINDI NG FORM	其它
					PIN	PIN	TUBE	TAPE		
N1	PIN5	PIN3	52	2UEWΦ0.2*1P				8.0mm/ 2圈	密绕	
N2	PIN2	NC	密平绕一层	2UEWΦ0.2*1P				8.0mm/ 2圈	密绕	
N3	PIN6	PIN7	50	TEX-EΦ0.2*1P				8.0mm/ 2圈	密绕	
N4	PIN3	PIN1	52	2UEWΦ0.2*1P				8.0mm/ 3圈	密绕	

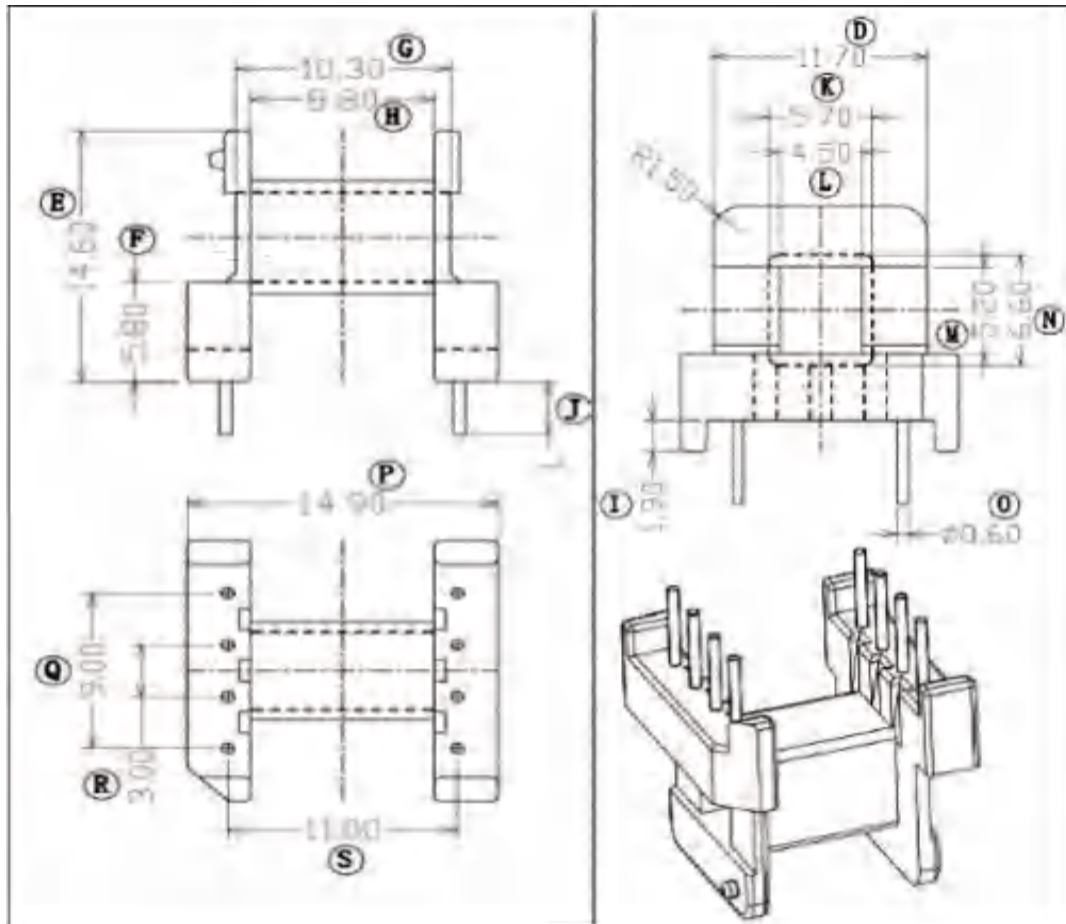
三、绕制结构图 (CONSTRUCTION DIAGRAM) :



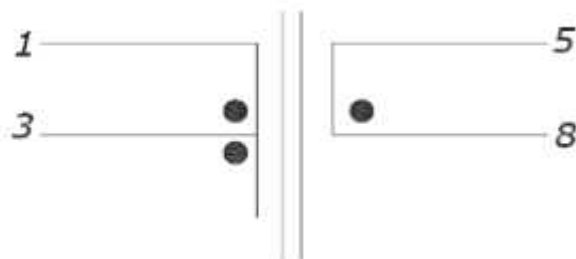
**7.0 Illustrations**

**Illustration 20** - Specification of transformer(T1) of TR012 for models JXL-TZ04-T10W-CCT-xx, JXL-TZ06-T12W-CCT-xx

一、外观尺寸图 PHYSICAL DIMENSION (UNIT: mm)

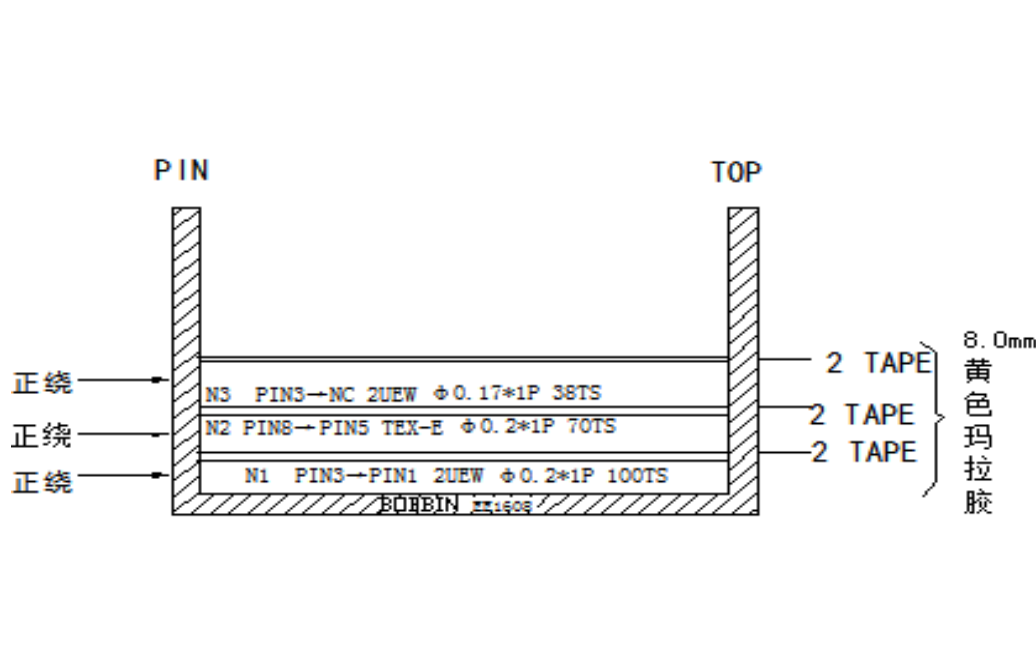


二、原理图:



**7.0 Illustrations**

**Illustration 21** - Specification of transformer(T1) of TR012 for models JXL-TZ04-T10W-CCT-xx, JXL-TZ06-T12W-CCT-xx (Cont'd)

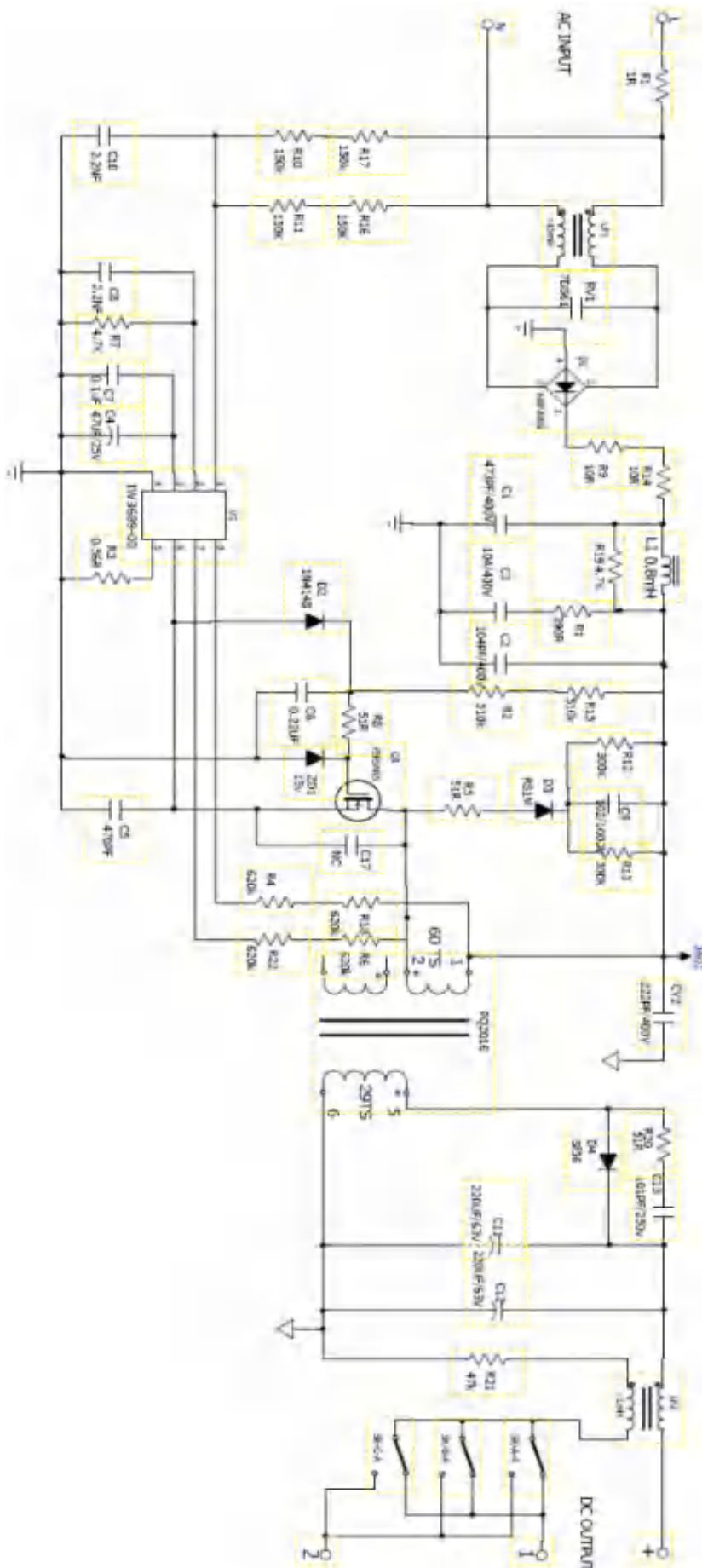


四. 绕线表 WINDING:

序号 NO.	起头 START	收尾 FINISH	圈数 TURNS	漆包线 WIRE	挡墙, 胶带圈数规格 MARGIN, TAPE TURNS				绕制 方式 WINDI NG CONDI TION	其它
					PIN	PIN	TUBE	TAPE		
N1	PIN3	PIN1	100	2UEW $\phi 0.2*1P$				8.0mm 2圈	密绕	
N2	PIN8	PIN5	70	2UEW $\phi 0.2*1P$				8.0mm 2圈	密绕	
N3	PIN3	NC	38	2UNW $\phi 0.17*1P$				8.0mm 2圈	密绕	

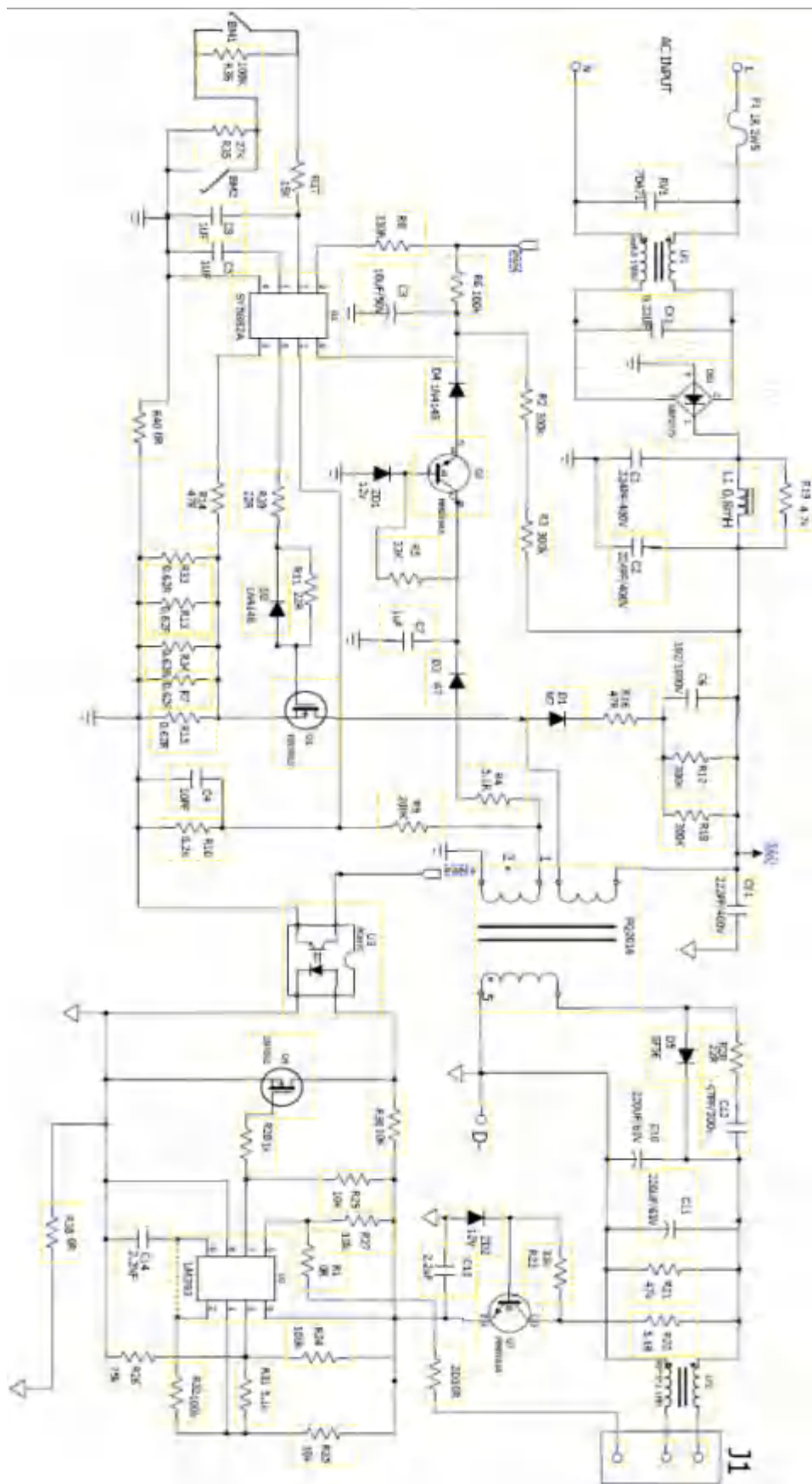
**7.0 Illustrations**

**Illustration 24 -** Circuit of driver of models JXL-TE06-T25W-CCT-xx, JXL-TE08-T25W-CCT-xx.



**7.0 Illustrations**

**Illustration 25 -** Circuit of driver of models JXL-TE06-E25/18/15W-UDD-xx, JXL-TE08-E25/18/15W-UDD-xx, JXL-TE08-E36W-UDD-xx, JXL-CA08-T25W-UDD-xx, JXL-CF08-T25W-UDD-xx, JXL-COB04-E15W-UDD-xx, JXL-COB06-F25/18/15W-UDD-xx, JXL-COB08-F25/18/15W-UDD-xx, JXL-COB08-F36W-UDD-xx.



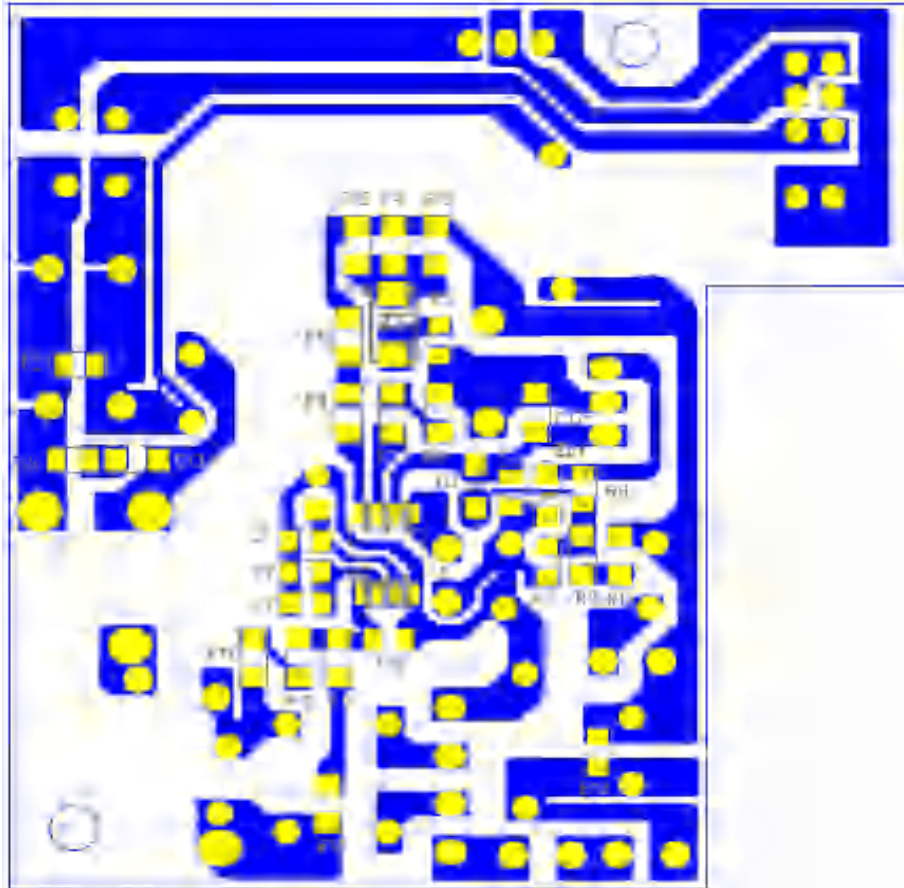
**7.0 Illustrations**

**Illustration 28** - Top of PCB layout of driver of models JXL-TE06-T25W-CCT-xx, JXL-TE08-T25W-CCT-xx



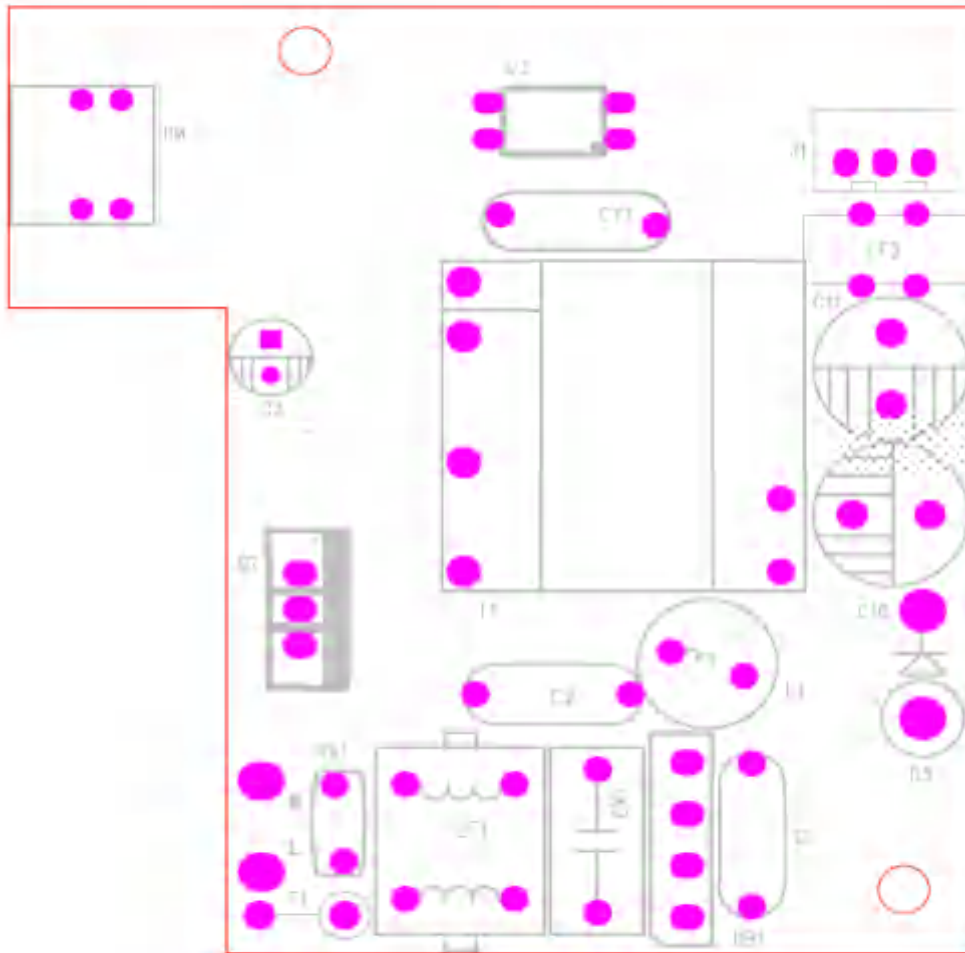
**7.0 Illustrations**

**Illustration 29** - Bottom of PCB layout of driver of models JXL-TE06-T25W-CCT-xx, JXL-TE08-T25W-CCT-xx



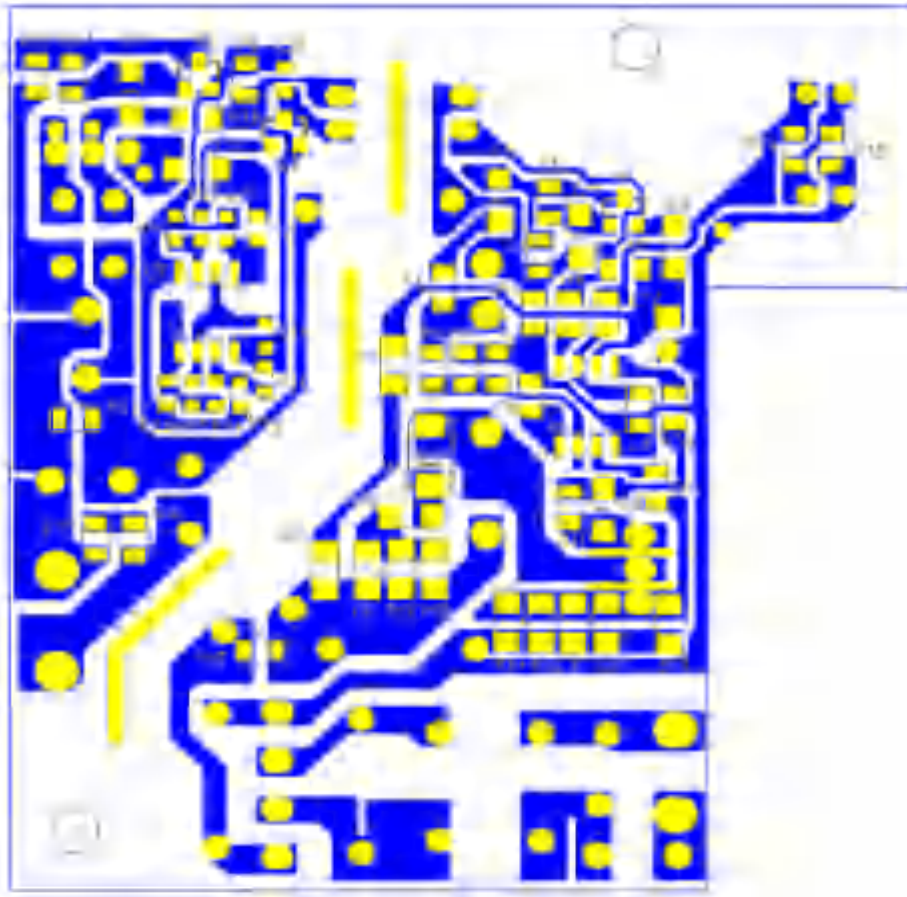
**7.0 Illustrations**

**Illustration 30** - Top of PCB layout of driver of models JXL-TE06-E25/18/15W-UDD-xx, JXL-TE08-E25/18/15W-UDD-xx, JXL-TE08-E36W-UDD-xx, JXL-CA08-T25W-UDD-xx, JXL-CF08-T25W-UDD-xx, JXL-COB04-E15W-UDD-xx, JXL-COB06-F25/18/15W-UDD-xx, JXL-COB08-F25/18/15W-UDD-xx, JXL-COB08-F36W-UDD-xx



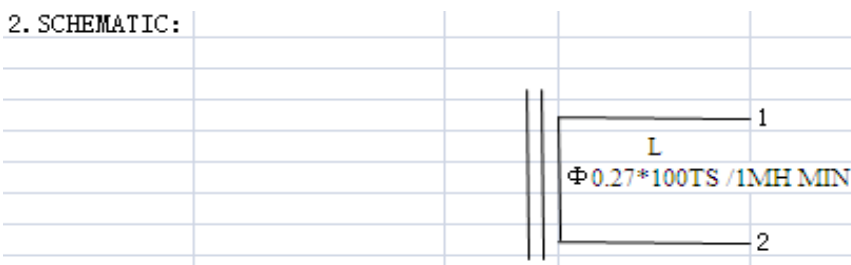
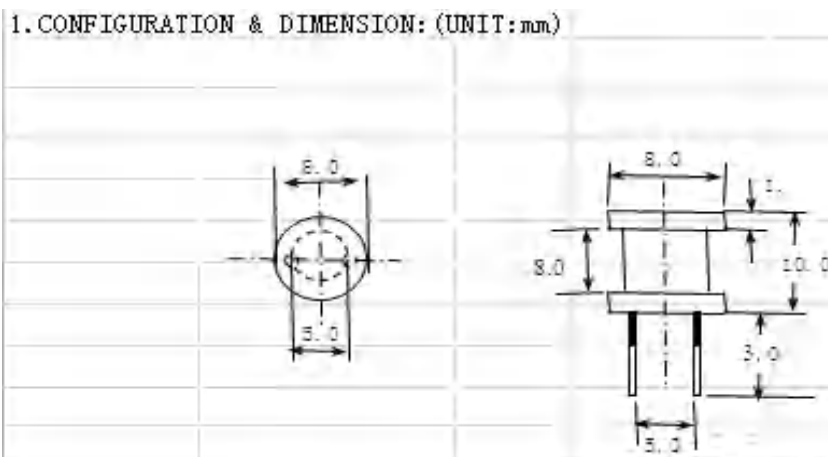
## 7.0 Illustrations

**Illustration 31** - Bottom of PCB layout of driver of models JXL-TE06-E25/18/15W-UDD-xx, JXL-TE08-E25/18/15W-UDD-xx, JXL-TE08-E36W-UDD-xx, JXL-CA08-T25W-UDD-xx, JXL-CF08-T25W-UDD-xx, JXL-COB04-E15W-UDD-xx, JXL-COB06-F25/18/15W-UDD-xx, JXL-COB08-F25/18/15W-UDD-xx, JXL-COB08-F36W-UDD-xx



**7.0 Illustrations**

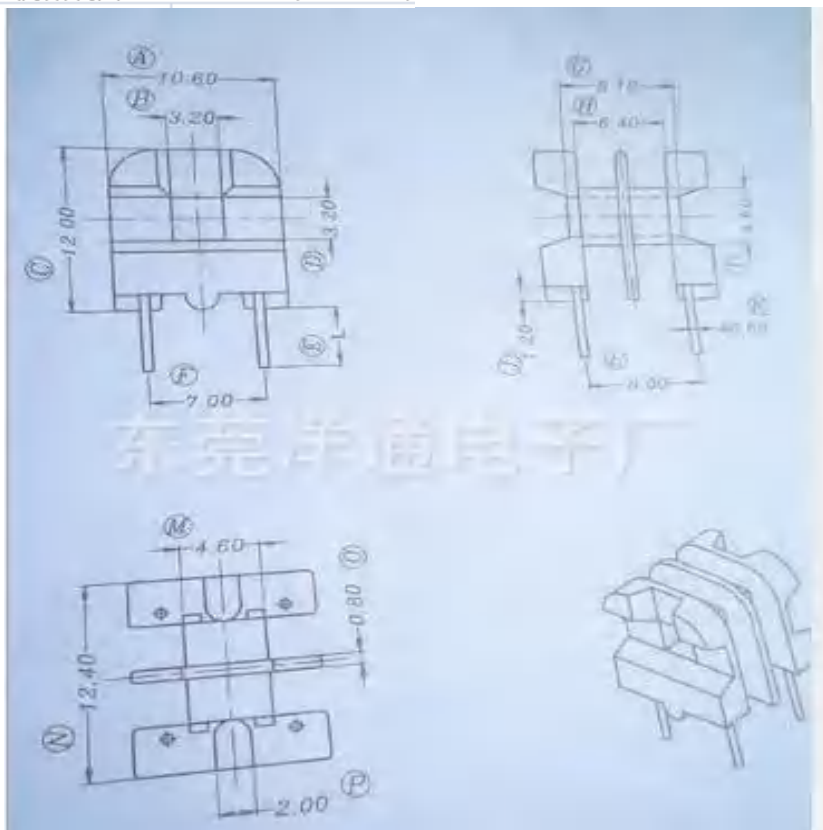
**Illustration 33** - Specification of inductor(L1) for models JXL-TE06-T25W-CCT-xx, JXL-TE08-T25W-CCT-xx, JXL-TE06-E25/18/15W-UDD-xx, JXL-TE08-E25/18/15W-UDD-xx, JXL-TE08-E36W-UDD-xx, JXL-CA08-T25W-UDD-xx, JXL-CF08-T25W-UDD-xx, JXL-COB04-E15W-UDD-xx, JXL-COB06-F25/18/15W-UDD-xx, JXL-COB08-F25/18/15W-UDD-xx, JXL-COB08-F36W-UDD-xx



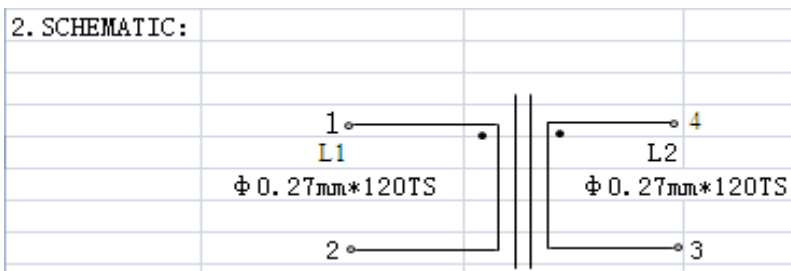
**7.0 Illustrations**

**Illustration 35** - Specification of inductor(LF1) for models JXL-TE06-T25W-CCT-xx, JXL-TE08-T25W-CCT-xx, JXL-TE06-E25/18/15W-UDD-xx, JXL-TE08-E25/18/15W-UDD-xx, JXL-TE08-E36W-UDD-xx, JXL-CA08-T25W-UDD-xx, JXL-CF08-T25W-UDD-xx, JXL-COB04-E15W-UDD-xx, JXL-COB06-F25/18/15W-UDD-xx, JXL-COB08-F25/18/15W-UDD-xx, JXL-COB08-F36W-UDD-xx.

1. 机械制图 DIMENSION: (UNIT:mm)

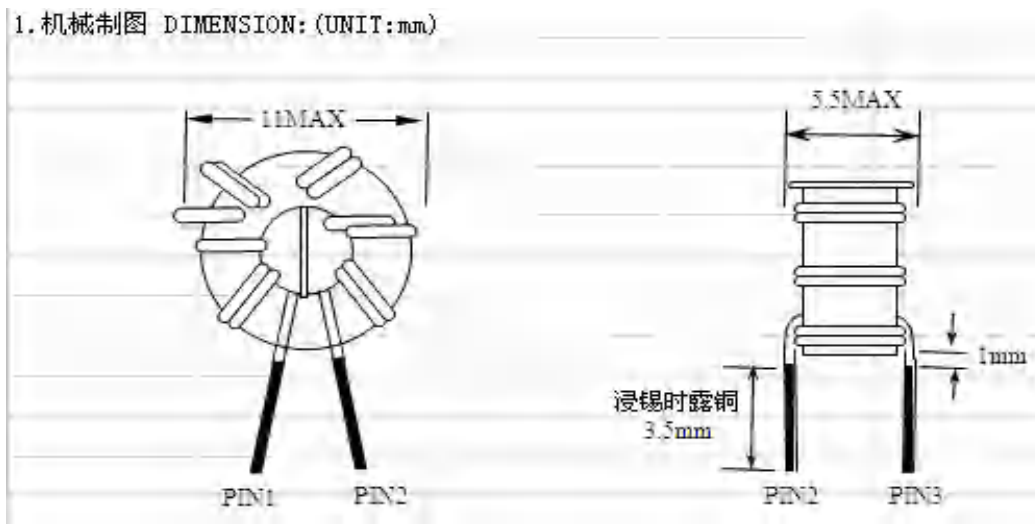


2. SCHEMATIC:

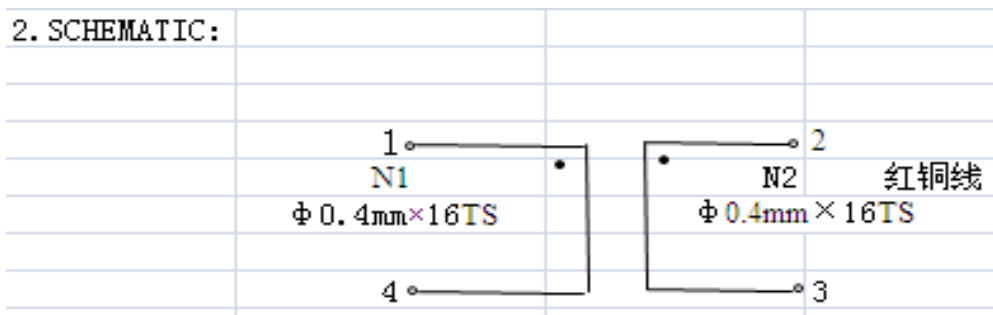


**7.0 Illustrations**

**Illustration 37** - Specification of inductor(LF2) for models JXL-TE06-T25W-CCT-xx, JXL-TE08-T25W-CCT-xx, JXL-TE06-E25/18/15W-UDD-xx, JXL-TE08-E25/18/15W-UDD-xx, JXL-TE08-E36W-UDD-xx, JXL-CA08-T25W-UDD-xx, JXL-CF08-T25W-UDD-xx, JXL-COB04-E15W-UDD-xx, JXL-COB06-F25/18/15W-UDD-xx, JXL-COB08-F25/18/15W-UDD-xx, JXL-COB08-F36W-UDD-xx



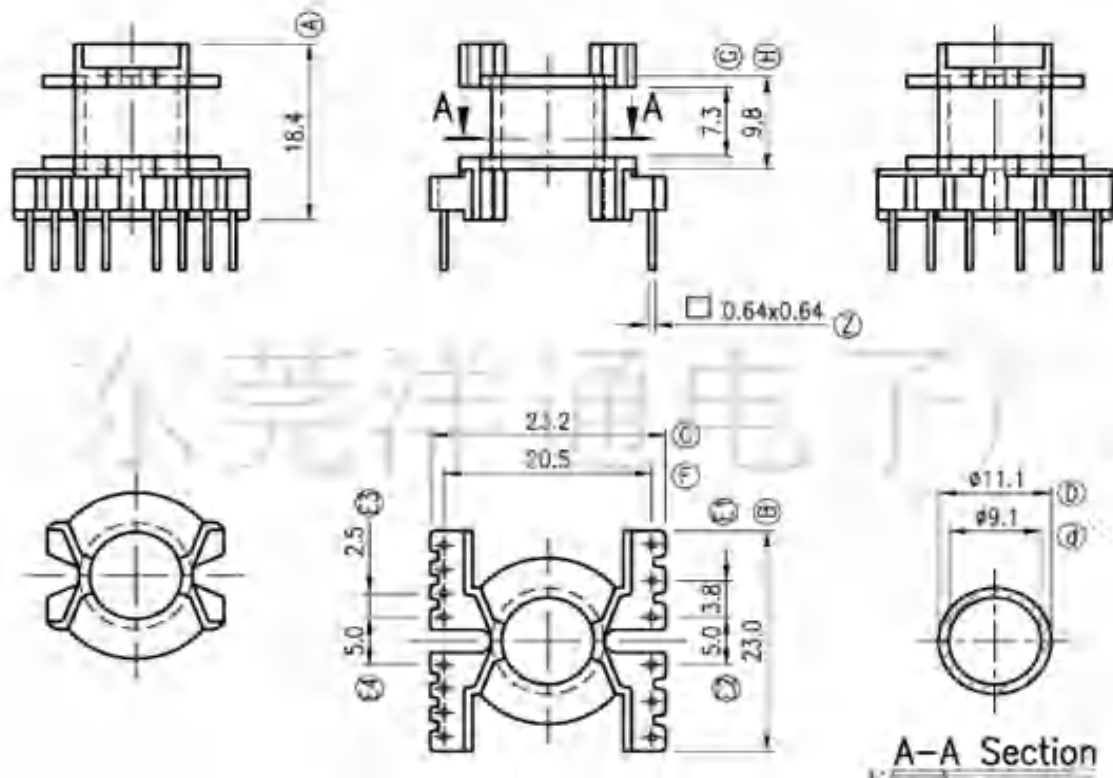
2. SCHEMATIC:



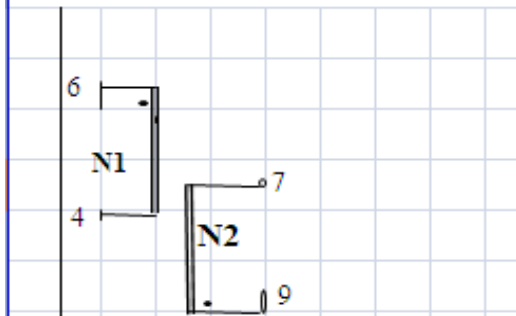
**7.0 Illustrations**

**Illustration 40** - Specification of transformer(T1) of TR018B for models JXL-TE06-T25W-CCT-xx, JXL-TE08-T25W-CCT-xx

一、外观图 (DIMENSION) :



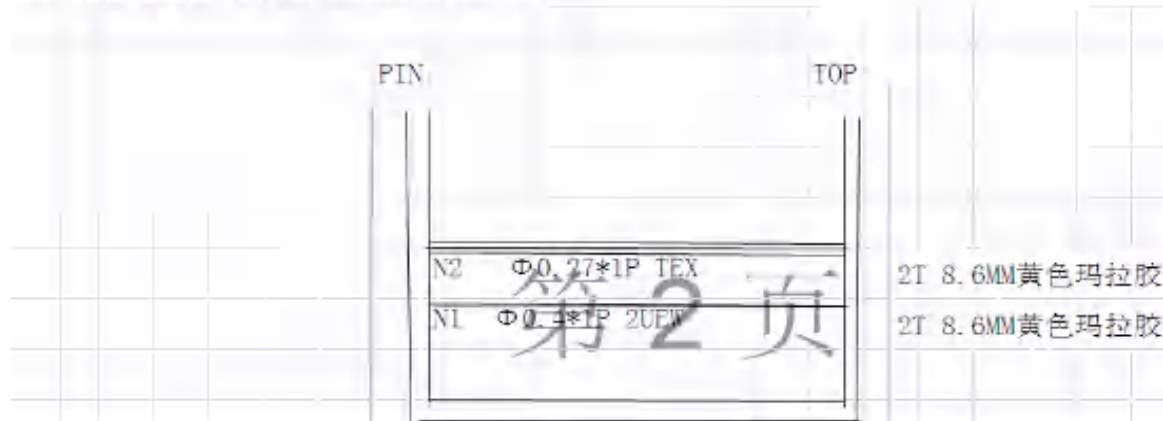
二、电器原理图 (CIRCUIT DIAGRAM) :



**7.0 Illustrations**

**Illustration 41** - Specification of transformer(T1) of TR018B for models JXL-TE06-T25W-CCT-xx, JXL-TE08-T25W-CCT-xx

三、绕制结构图(CONSTRUCTION DIAGRAM)：



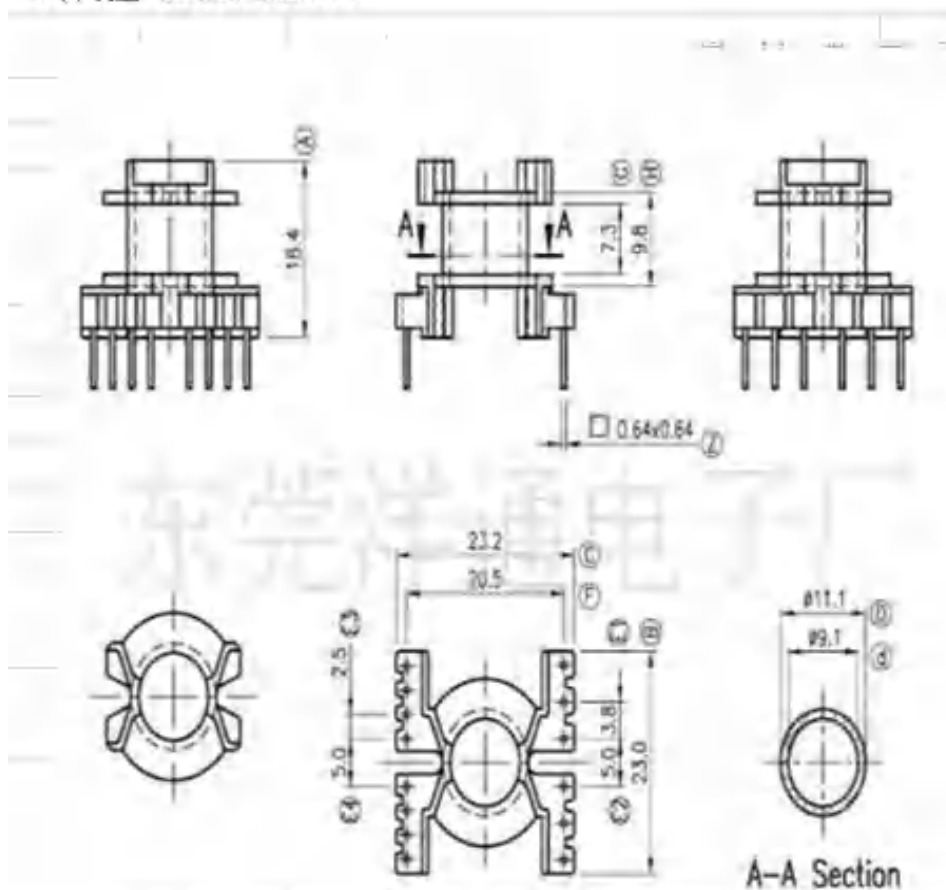
四、绕线表(WINDING)：

序号 NO.	起头 START	收尾 FINISH	圈数 TURNS	漆包线 WIRE	挡墙、胶带圈数规格 MARGIN、TAPE TURNS				绕制方式 WINDING CONDITION IOX
					PIN	PIN	TUBE	TAPE	
N1	PIN6	PIN4	60	2UEWΦ0.4*1P				7.8mm/2 圈	密绕
N2	PIN9	PIN7	29	TEX Φ0.27*1P				7.8mm/2 圈	密绕

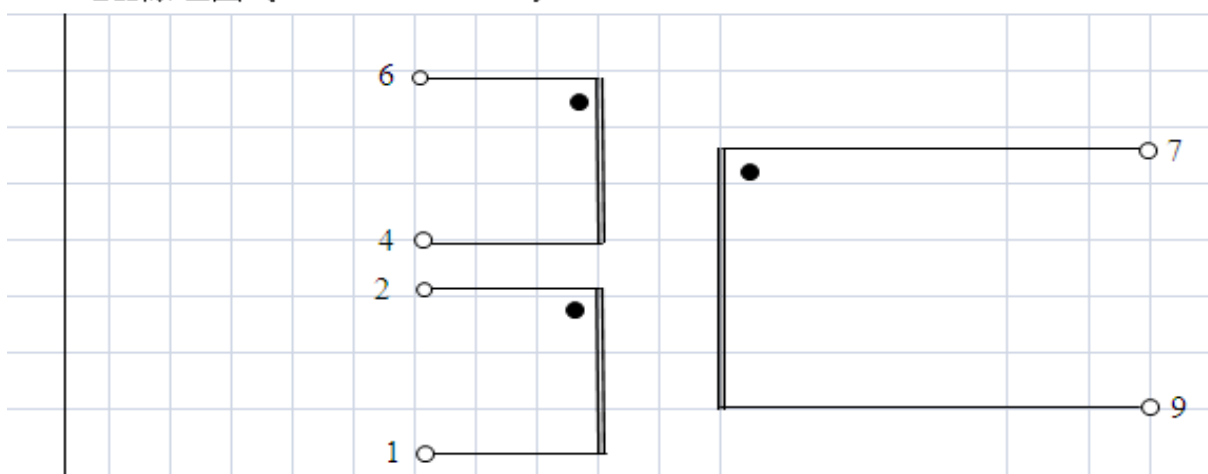
**7.0 Illustrations**

**Illustration 44** - Specification of transformer(T1) of DM001A for models JXL-TE06-E25/18/15W-UDD-xx, JXL-TE08-E25/18/15W-UDD-xx, JXL-CA08-T25W-UDD-xx, JXL-CF08-T25W-UDD-xx, JXL-COB04-E15W-UDD-xx, JXL-COB06-F25/18/15W-UDD-xx, JXL-COB08-F25/18/15W-UDD-xx

一、外观图 (DIMENSION) :



二、电器原理图 (CIRCUIT DIAGRAM) :



**7.0 Illustrations**

**Illustration 45** - Specification of transformer(T1) of DM001A for models JXL-TE06-E25/18/15W-UDD-xx, JXL-TE08-E25/18/15W-UDD-xx, JXL-CA08-T25W-UDD-xx, JXL-CF08-T25W-UDD-xx, JXL-COB04-E15W-UDD-xx, JXL-COB06-F25/18/15W-UDD-xx, JXL-COB08-F25/18/15W-UDD-xx

三、绕制结构图(CONSTRUCTION DIAGRAM)。

<b>第 2 页</b>		
N1	PIN1-PIN2 2UEW $\Phi$ 0.2*1P 15TS	2T 10MM黄色玛拉胶
N2	PIN7-PIN9 TEX $\Phi$ 0.5*1P 22TS	2T 10MM黄色玛拉胶
N1	PIN4-PIN6 2UEW $\Phi$ 0.27*1P 66TS	2T 10MM黄色玛拉胶

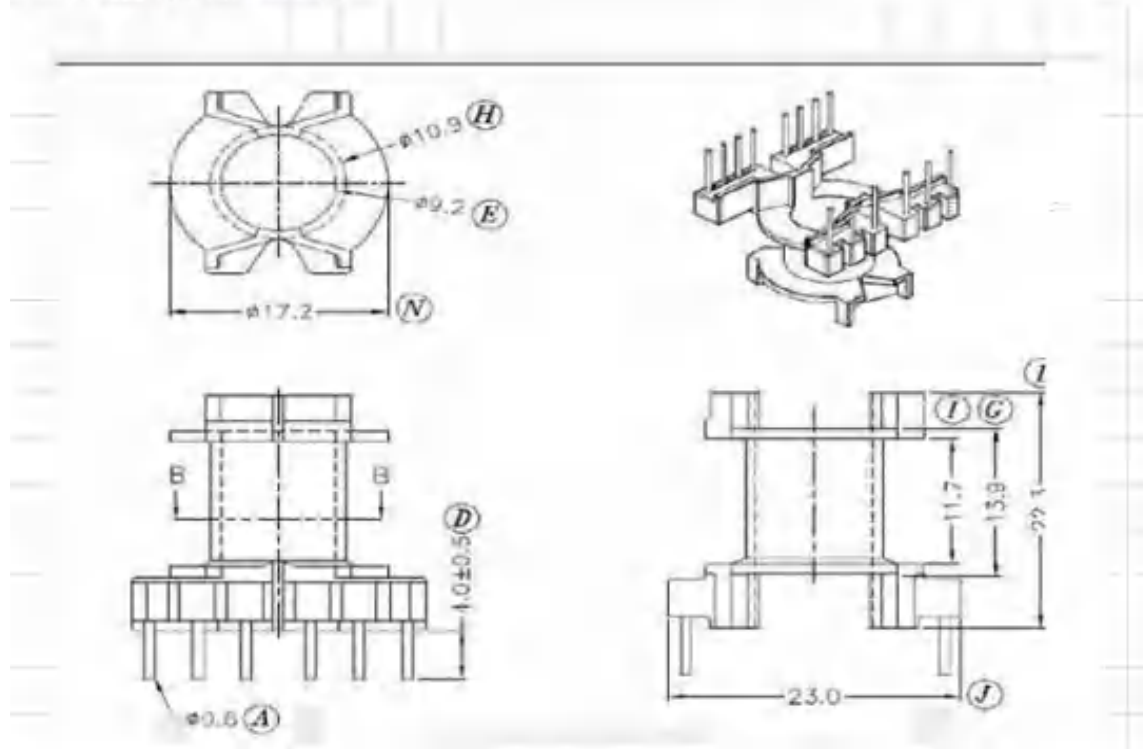
四、绕线表WINDING:

序号 NO.	起头 START	收尾 FINISH	圈数 TURNS	漆包线 WIRE	挡墙、胶带圈数规格 MARGIN, TAPE TURNS				绕制 方式 WINDI NG CONDI TION
					PIN	PIN	TUBE	TAPE	
N1	PIN4	PIN6	66	2UEW $\Phi$ 0.27*1P				10mm 2 圈	密绕
N2	PIN7	PIN9	22	TEX $\Phi$ 0.5*1P				10mm 2 圈	密绕
N3	PIN1	PIN2	15	2UNW $\Phi$ 0.2*1P				10mm 2 圈	密绕

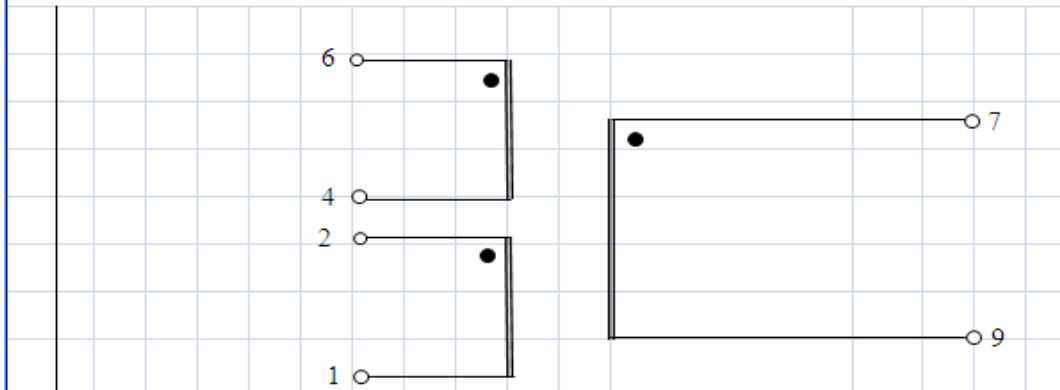
**7.0 Illustrations**

**Illustration 46** - Specification of transformer(T1) of DM001B for models JXL-TE08-E36W-UDD-xx, JXL-COB08-F36W-UDD-xx

一、外观图 (DIMENSION) :



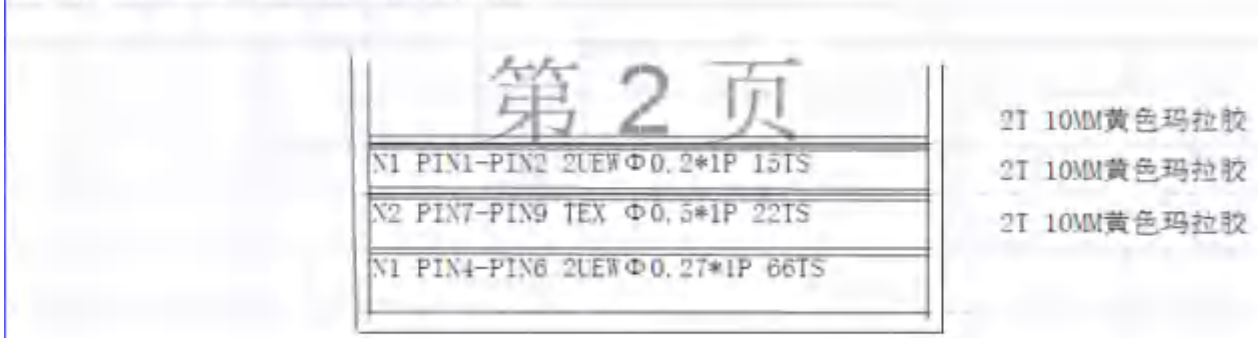
二、电器原理图 (CIRCUIT DIAGRAM) :



**7.0 Illustrations**

**Illustration 47** - Specification of transformer(T1) of DM001B for models JXL-TE08-E36W-UDD-xx, JXL-COB08-F36W-UDD-xx

三、绕制结构图(CONSTRUCTION DIAGRAM)：



四、绕线表(WINDING)：

序号 NO.	起头 START	收尾 FINISH	圈数 TURNS	漆包线 WIRE	排通、胶带圈数规格 MARGIN, TAPE TURNS				绕制方 式 WINDIN G CONDIT ION	备注
					PIN	PIN	TUBE	TAPE		
N1	PIN4	PIN6	66	2UEN $\Phi 0.27*1P$				10mm/2 ■	密绕	
N2	PIN7	PIN9	22	TEX $\Phi 0.5*1P$				10mm/2 ■	密绕	
N3	PIN1	PIN2	15	2UNW $\Phi 0.2*1P$				10mm/2 ■	密绕	

**7.0 Illustrations**

**Illustration 48** - Component difference table for driver model TR018A, TR018C

Models TR018A, TR018C consist of same circuit and PCB layout, the difference of component is listed below					
Model#	CX1#	LF1#	LF2#	T1#	Is there SK#
TR018A#	NA#	15mH#	1mH#	TR018A#	NO#
TR018C#	NA#	15mH#	1mH#	TR018C#	NO#

**7.0 Illustrations**

**Illustration 49** - Component difference table for driver model DM001A, DM001B

Models DM001A and DM001B consist of same circuit and PCB layout, the difference of component is listed below:

Model	R7	T1
DM001A	1.3Ω	DM001A
DM001B	0.625Ω	DM001B

## 7.0 Illustrations

### Illustration 50 - LED Spec. and model No.list .

- 1)If:300mA, Vf:27-30V  
JXL-COB02-R08W-CCT,JXL-COB02-S08W-CCT
- 2)If:300mA, Vf:36-40V  
JXL-COB04-R12W-CCT,JXL-COB04-S12W-CCT
- 3)If:300mA, Vf:45-48V  
JXL-COB04-R15W-CCT,JXL-COB04-S15W-CCT
- 4)If:300-690mA, Vf:42-48V  
JXL-COB04-S15W-UDN-XX, JXL-COB04-R15W-UDN-XX
- 5)If:150mA, Vf:3.1-3.3V  
JXL-SMD04-G10W-CCT, JXL-TE04-T12W-UDN-XX, JXL-TEH04-T12W-UDN -XX,  
JXL-TZ04-T10W-UDN-XX, JXL-TZ06-T12W-UDN-XX, JXL-CA04-T10W-UDN-XX,  
JXL-CA06-T12W-UDN-XX, JXL-TZ04-R10W-CCT, JXL-TZ06-R12W-CCT, JXL-CA04-T10W-CCT,  
JXL-CA06-T12W-CCT, JXL-CM06-T12W-CCT, JXL-CM04-T10W-CCT, JXL-CF04-T10W-CCT, JXL-CF06-T12W-  
CCT
- 6)If:240mA, Vf:5.8-6.2V  
JXL-TX05-T10W-UDN-XX,JXL-TX10-T18W-UDN-XX,JXL-TXH10-T18W-UDN-XX,JXL-TXH05-T10W-UDN-XX,
- 7)If:300-690mA, Vf:27-29V  
JXL-COB02-R08W-UDN-XX, JXL-COB02-S08W-UDN-XX
- 8)If:300-690mA, Vf:36-42V  
JXL-COB04-R12W-UDN-XX, JXL-COB04-S12W-UDN-XX
- 9)If:300-690mA, Vf:30-36V

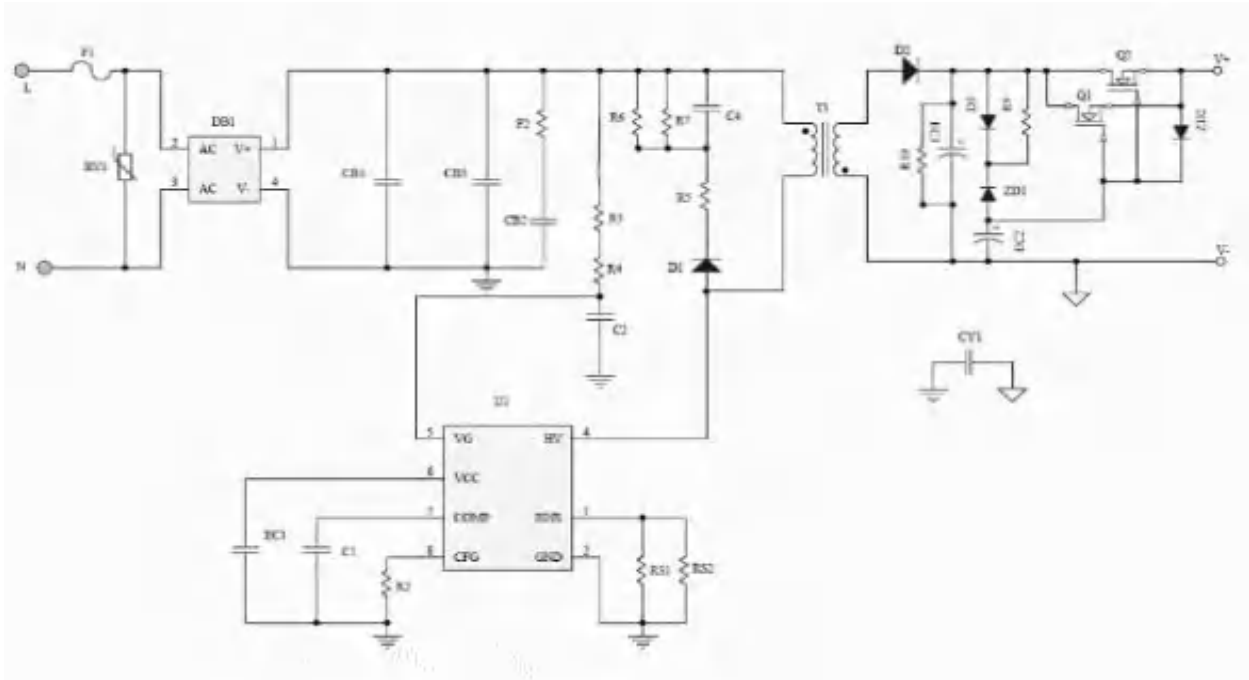
## 7.0 Illustrations

### Illustration 51 - LED Driver and model No.list .

- 1)TR-023A For 3 models  
JXL-TE04-T12W-UDN-XX,JXL-TX05-T10W-UDN-XX,JXL-TXH05-T10W-UDN-XX
- 2)TR-018D For 3 models  
JXL-COB04-S15W-UDN-XX,JXL-COB04-R15W-UDN-XX
- 3)TR-031A For 2 models  
JXL-TX10-T18W-UDN-XX,JXL-TXH10-T18W-UDN-XX,
- 4)TR-012B For 15 models  
JXL-COB04-G10W-CCT,JXL-SMD04-G10W-CCT,JXL-TZ04-R10W-CCT,JXL-TZ06-R12W-CCT,JXL-COB04-R12W-CCT,JXL-COB04-S12W-CCT,JXL-COB02-R08W-CCT,JXL-COB02-S08W-CCT,JXL-CA04-T10W-CCT,JXL-CA06-T12W-CCT,JXL-CM06-T12W-CCT,JXL-CM04-T10W-CCT, JXL-CF04-T10W-CCT,JXL-CF06-T12W-CCT
- 5)TR-030 For 2 models  
JXL-COB04-R15W-CCT,JXL-COB04-S15W-CCT
- 6)TR-019 for 13 models  
JXL-COB02-R08W-UDN-XX,JXL-COB02-S08W-UDN-XX,JXL-COB04-R12W-UDN-XX,JXL-COB04-S12W-UDN-XX,JXL-TE06-T12W-UDN-XX  
,JXL-TZ04-T10W-UDN-XX,JXL-TZ06-T12W-UDN-XX,JXL-CA04-T10W-UDN-XX,JXL-CA06-T12W-UDN-XX,JXL-TEH04-T12W-UDN -XX

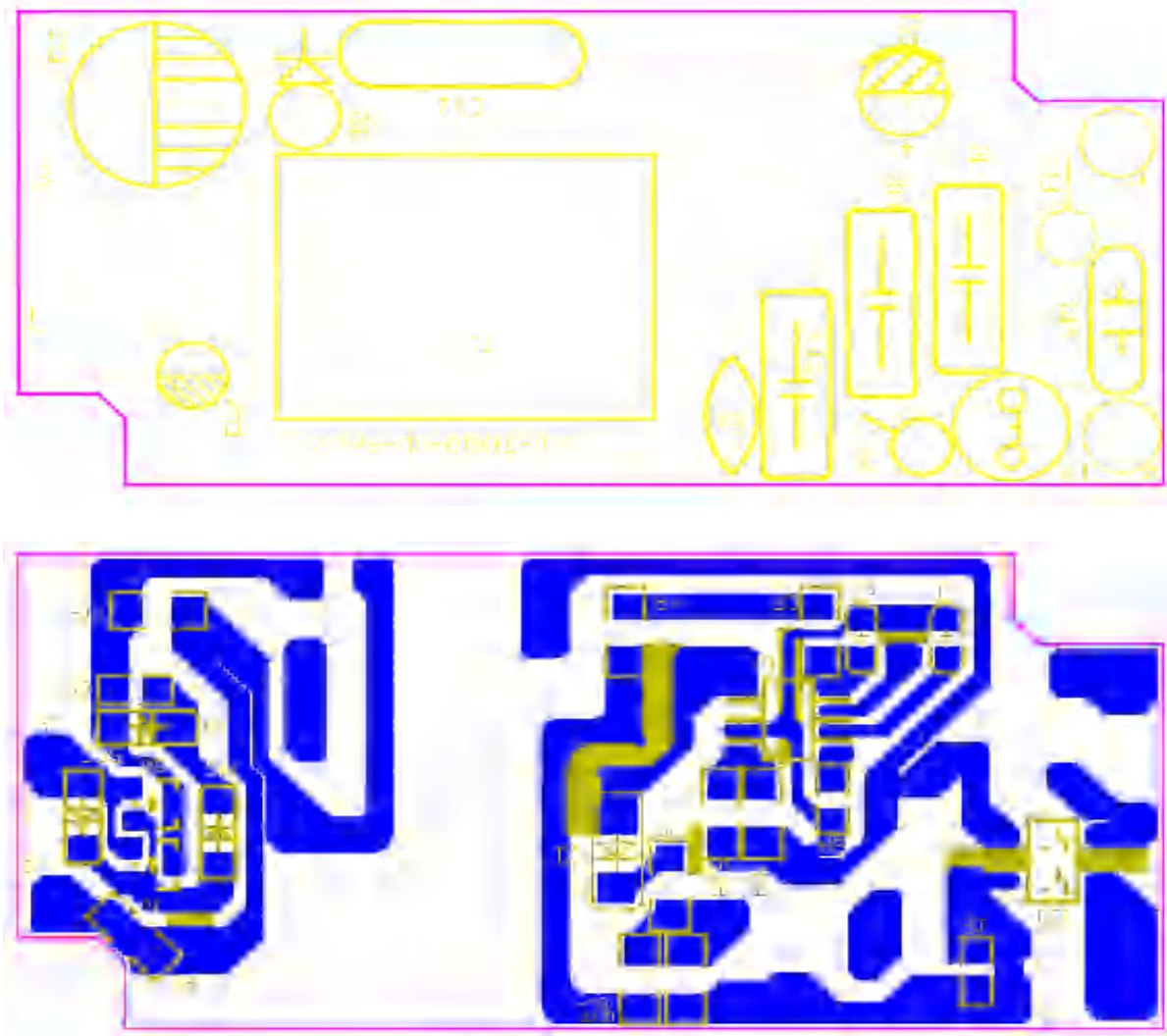
**7.0 Illustrations**

**Illustration 58** - Circuit diagram for LED Driver model TR-019



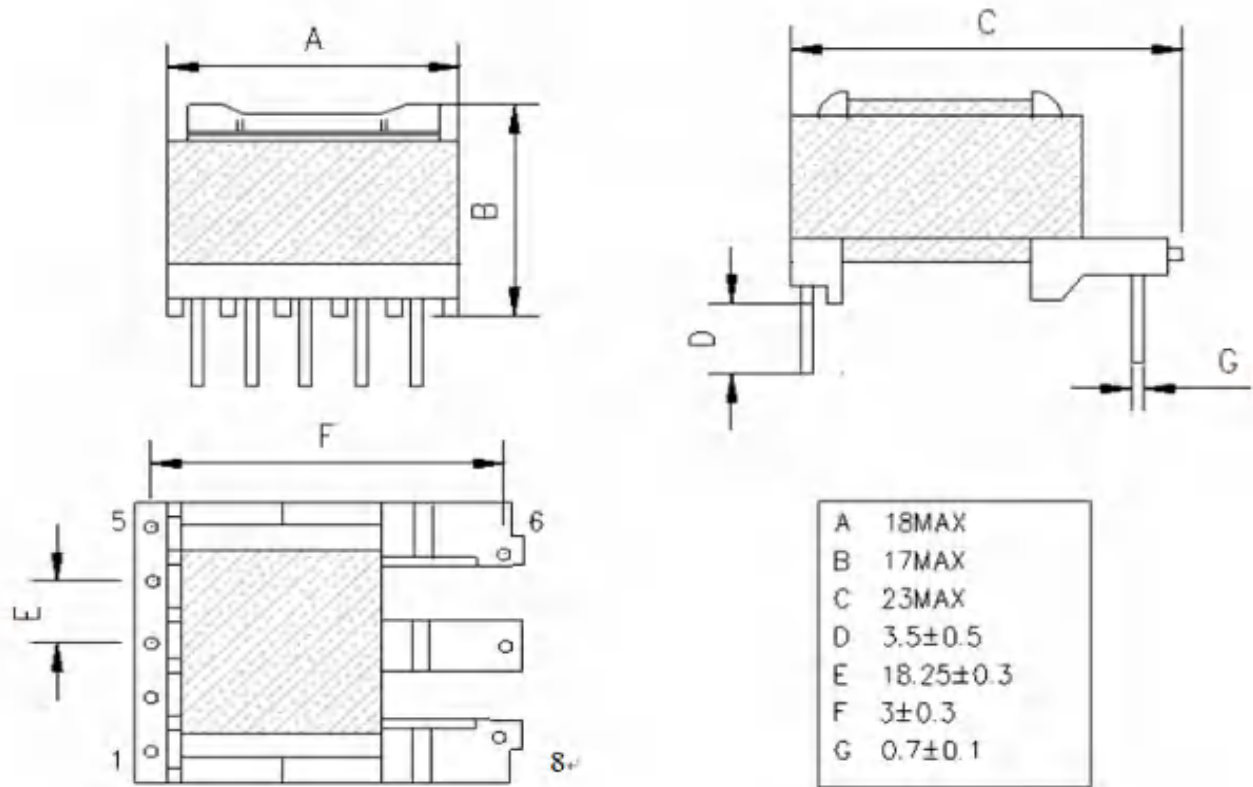
**7.0 Illustrations**

**Illustration 59 - PCB Layout diagram for LED Driver model TR-019**



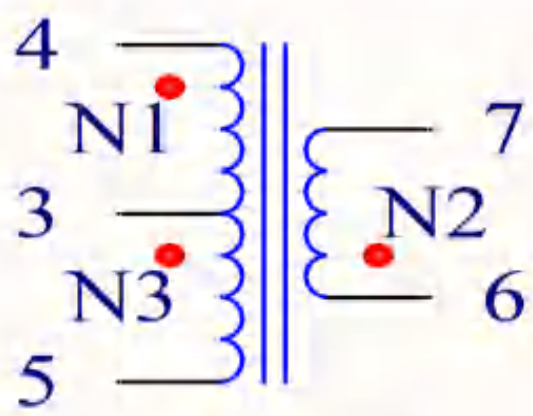
**7.0 Illustrations**

**Illustration 60 - Transformer T1 Specification for model TR-019 &TR-012B.**



备注：  
 1.成品真空浸油漆烘干处理、磁芯需要反包胶带  
 2.空 1.2.8.脚，3 脚剪余头。

二、绕线数据 Electrical schematic diagram:



序号	绕组	起绕-终绕	线 径	圈数	绕 法	胶 带
1	N1	4-3	2UEW $\phi$ 0.21*1P	60	密绕	2TS
2	N2	6-7	2TILW -F2 155(F) $\phi$ 0.25*1P (三层绝缘线)	50	密绕	2TS
3	N3	3-5	2UEW $\phi$ 0.21*1P	45	密绕	2TS

**7.0 Illustrations**

**Illustration 61 - Transformer T1 Specification for model TR-019 &TR-012B.**

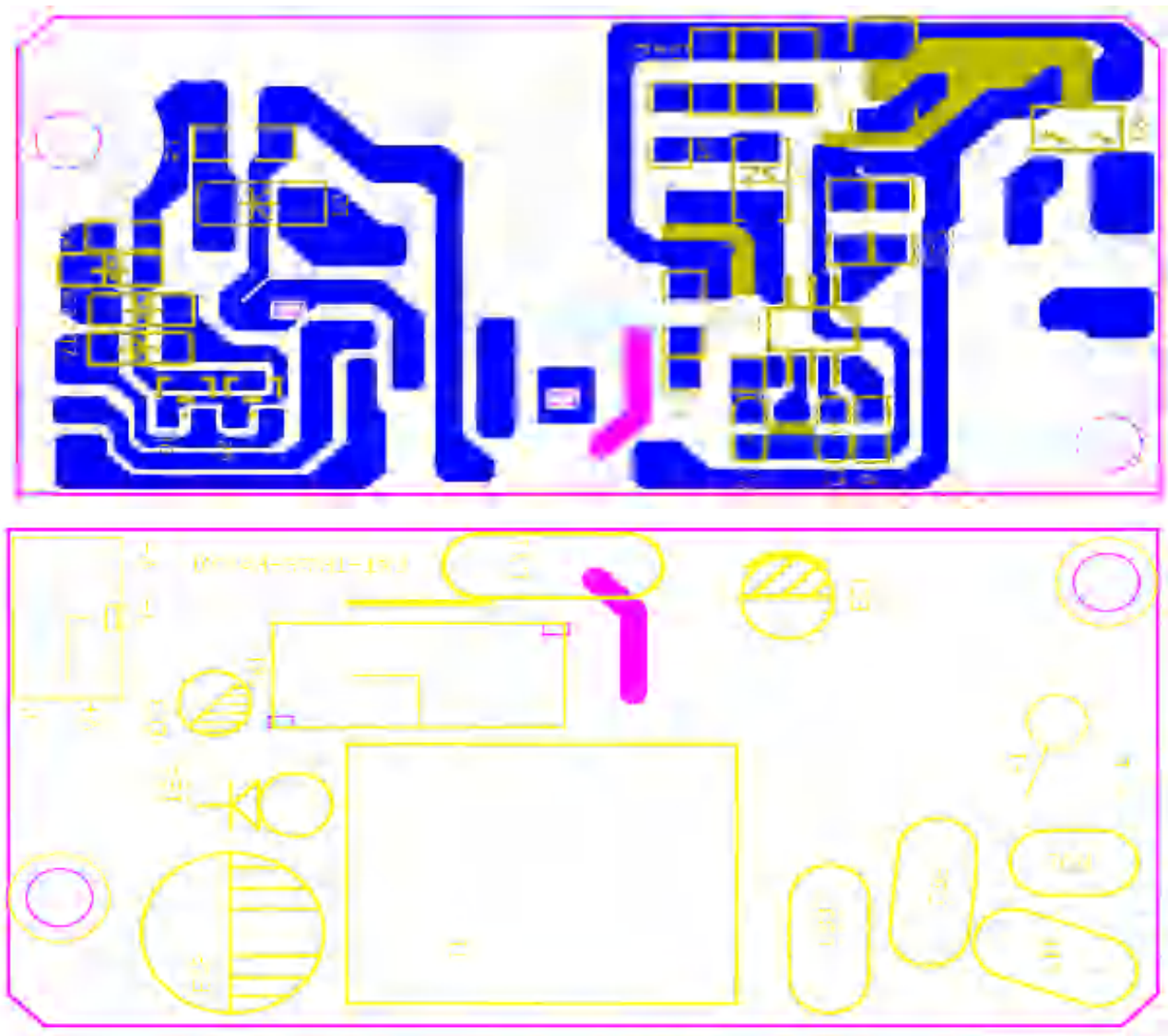
四、结构图及材料 Structural diagrams and materials: -  
 (-).材料清单(见下表)

NO.	ITEM	MATERIAL	SUPPLIER OR MANUFACTURER	CLASS	UL NO.
3.1	CORE 磁芯	EE16158/PC44	HAINING WANLI ELECTRONICS CO.,LTD		
3.2	BOBBIN 骨架	EE16(5+3)卧式单边加宽 (T378JB)	CHANG CHUN PLASTICS CO.LTD	130℃	E59481
3.3	WIRE 线材	XUEWEN155.QA/X-4/155	WU HU COPPER CORNS ELECTRICIANS LTD	155℃	E316176
		THW-F2 155(F)	TAYA ELECTRIC WIRE & CABLE CO.LTD	155℃	E225803
3.4	TAPE 胶带	JY312V 淡黄色	SUZHOU MEILADUONA ELECTRIC MATERIAL CO.LTD	130℃	E188295
3.5	SOLDER 锡	107B	THOUSAND ISLAND METAL FOIL Co.,LTD	420℃	
3.6	VARNISH 凡立水	1032C44	SHENZHEN MINGSHUNJIE TECHNOLOGY CO.,LTD		E113475



**7.0 Illustrations**

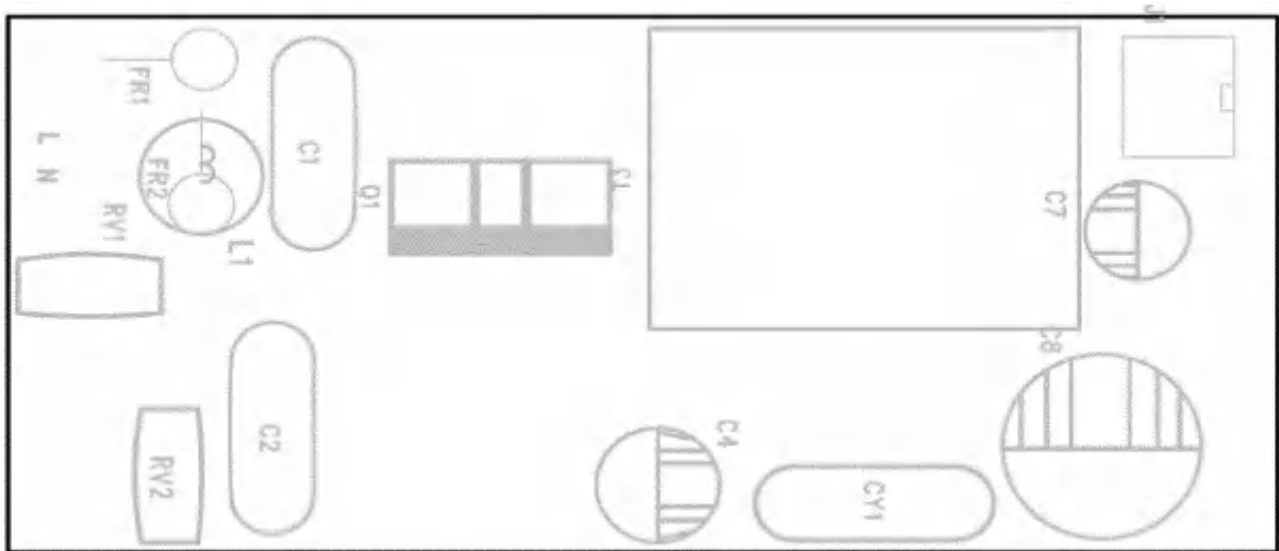
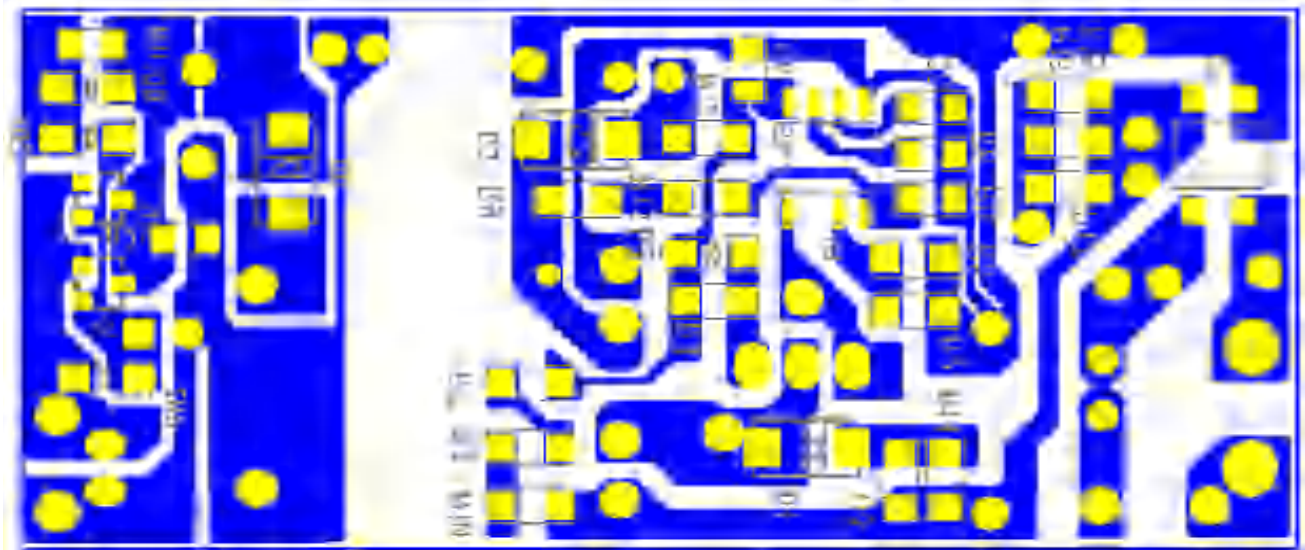
**Illustration 63** - Circuit diagram for LED Driver model TR-012B.





**7.0 Illustrations**

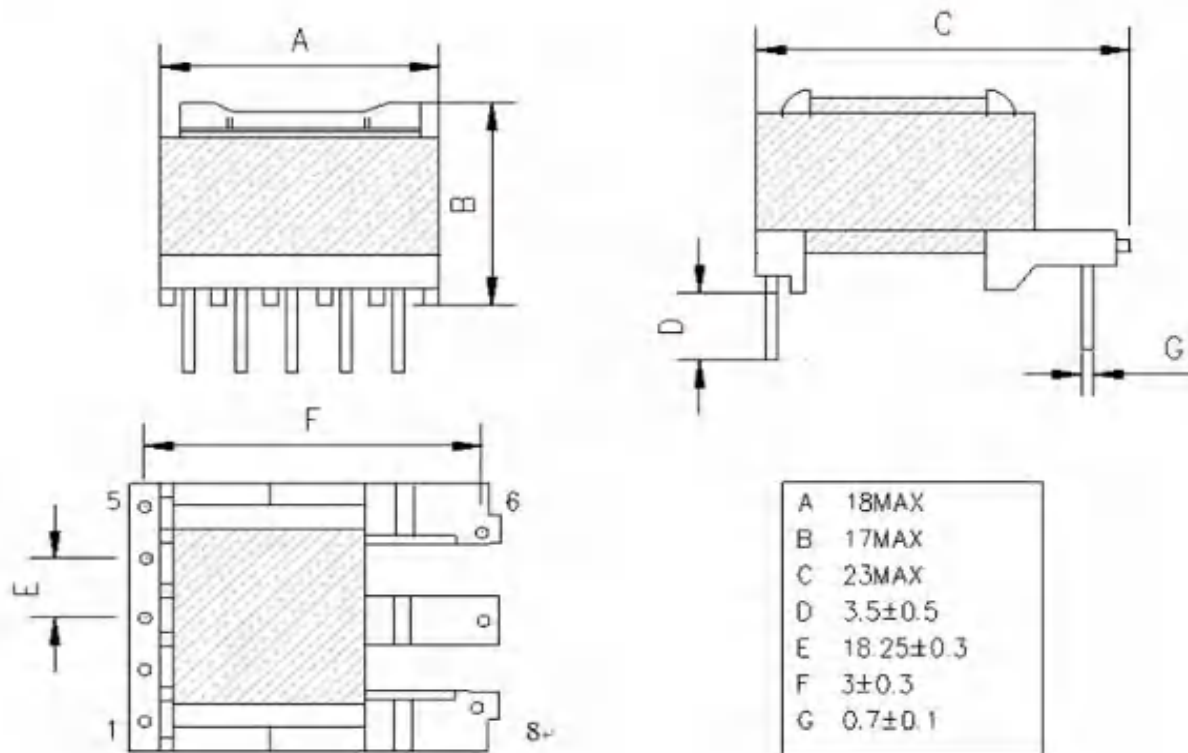
**Illustration 65 - PCB Layout diagram for LED Driver model TR-023A**



**7.0 Illustrations**

**Illustration 66 - Transformer T1 Specification for model TR-023A.**

一、外观结构图 **Oveall dimensions diagram (units:mm)**

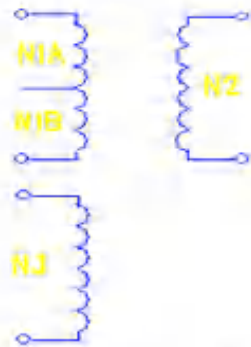


备注:

- 1.成品真空浸油漆烘干处理。
- 2.空.8.脚, 3脚剪余头。

**7.0 Illustrations**

**Illustration 67 - Transformer T1 Specification for model TR-023A.**



序号	绕组	起绕--终绕	线 径	圈数	绕 法	胶 带
1	N1A	2--3	2UEW $\phi$ 0.21*1P	58	密绕	2TS
2	N2	6--8	TILW -F2 155(F) $\phi$ 0.25*1P	45	密绕	2TS
3	N1B	3--1	2UEW $\phi$ 0.21*1P	27	密绕	2TS
4	N3	4--5	2UEW $\phi$ 0.18*1P	56	密绕	2TS

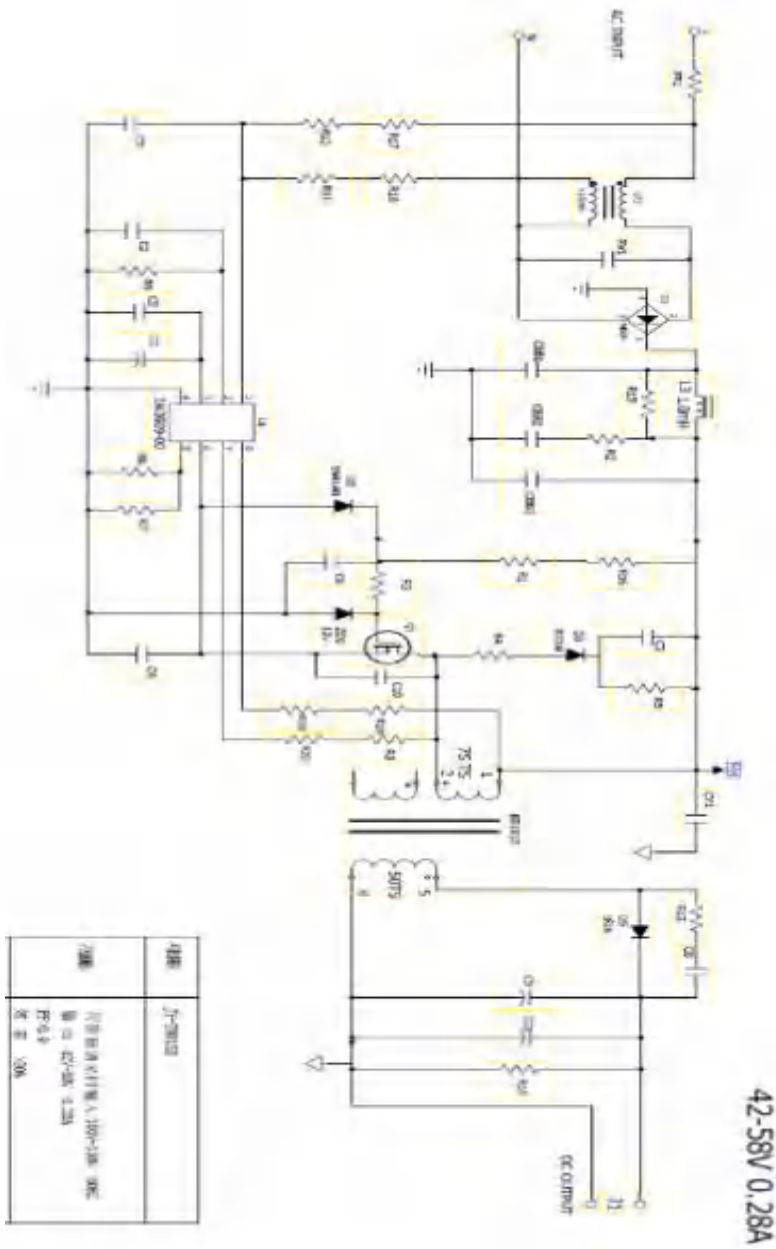
**四、结构图及材料 Structural diagrams and materials:**

(一).材料清单(见下表)

NO.	ITEM	MATERIAL	SUPPLIER OR MANUFACTURER	CLASS	UL NO.
3.1	CORE磁芯	EE1615/PC44	HAINING WANLI ELECTRONICS CO.LTD	-	-
3.2	BOBBIN骨架	EE16(S-3)卧式单边加宽 #1378JB	CHANG CHUN PLASTICS CO.LTD	130C	E59481
3.3	WIRE线材	X UEWN/155,Q3 X $\phi$ 155	WUHU COPPER CORWY ELECTRICIAN LTD	155C	E318170
		TILW -F2 155(F)	TAYA ELECTRIC WIRE & CABLE CO.LTD	155C	E225803
3.4	TAPE胶带	JV312Y淡黄色	SURET MAIADCO54 ELECTRIC MATERIAL CO.LTD	130C	E188295
3.5	SOLDER锡	107H	THOUSAND ISLAND METAL FOIL Co.,LTD	420C	-
3.6	VARNISH凡立水	1032CJ1	SHENZHEN MINGSHUNJIE TECHNOLOGY CO. LTD	-	E213473

**7.0 Illustrations**

**Illustration 68 - Circuit diagram for LED Driver model TR-018D**



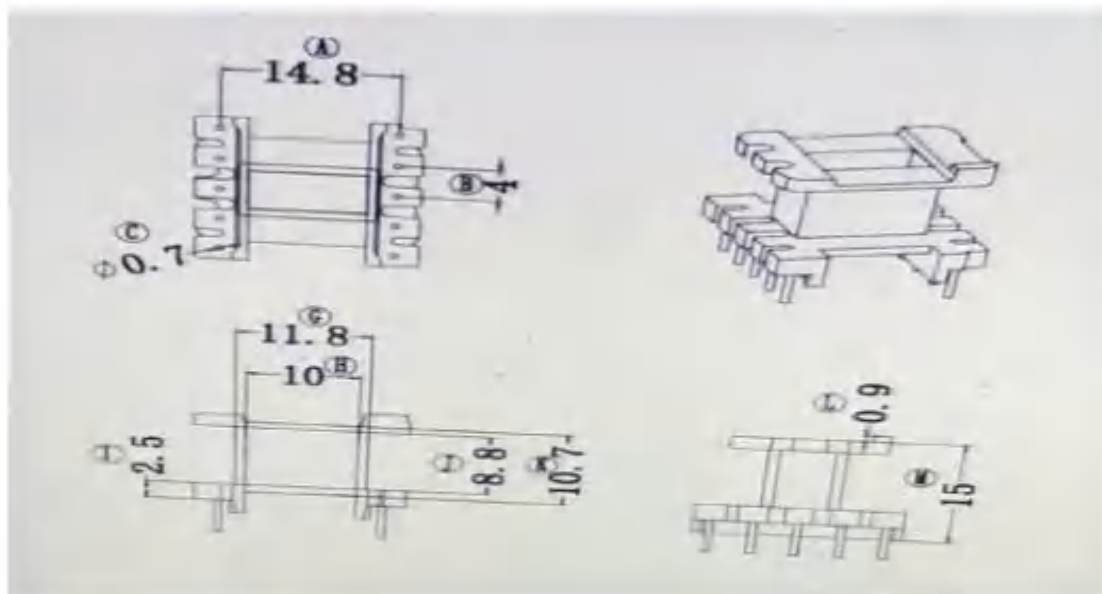
料號	J1-018D
規格	LED 驅動器 180-180 0.28A 輸入: AC 220V 50/60Hz 輸出: DC 42-58V 0.28A 功率: 10W



7.0 Illustrations

Illustration 70 - Transformer T1 Specification for model TR-018D.

一、外观结构图 Overall dimensions diagram (units:mm)

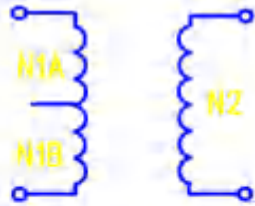


备注：

- 1.成品真空浸油漆烘干处理。
- 2.空 3,4,7,9,10脚, 5脚剪余头。

**7.0 Illustrations**

**Illustration 71 - Transformer T1 Specification for model TR-018D.**



序号	绕组	起绕-终绕	线 径	圈数	绕 法	胶 带
1	N1A	2--5	2UEW $\phi$ 0.3*1P	50	密绕	2TS
2	N2	6--8	TILW -F2 155(F) $\phi$ 0.25*1P (三层绝缘线)	50	密绕	2TS
3	N1B	5--1	2UEW $\phi$ 0.3*1P	5	密绕	2TS

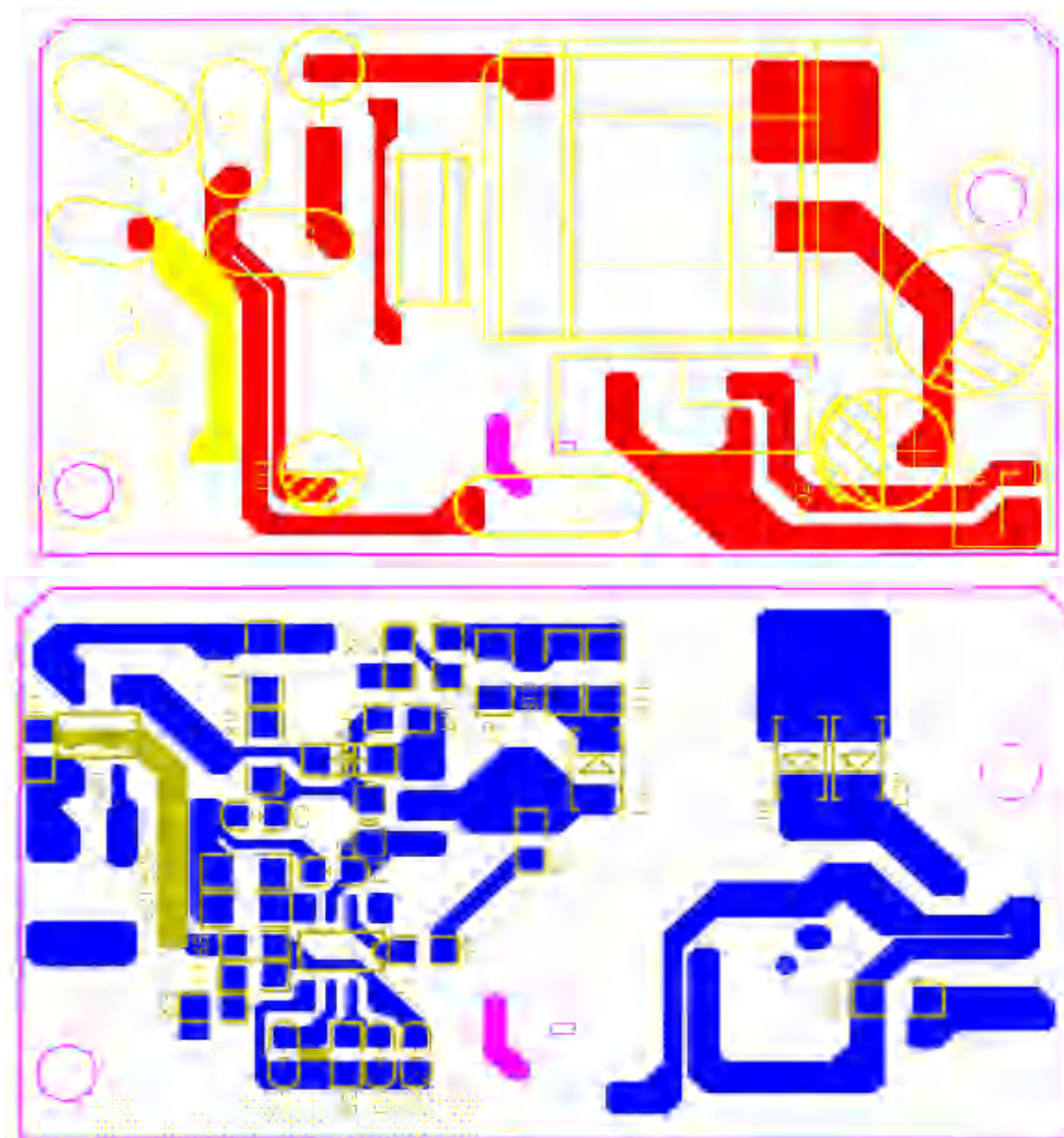
(一).材料清单(见下表)

NO	ITEM	MATERIAL	SUPPLIER OR MANUFACTURER	CLASS	UL NO
3.1	CORE 磁芯	EE16158/PC44	BAISING WANLE ELECTRONICS CO.LTD		
3.2	BOBBIN 骨架	EE1910(5+5)立式单边 T378JB	CHANG CHUN PLASTICS CO.LTD	130C	E59461
3.3	WIRE 线材	XUEWN/155QA/X-1/155	WU HU COPPER CORWN ELECTRICIAN LTD	155T	E32670
		TILW -F2 155(F)	TAYA ELECTRIC WIRE & CABLE CO.LTD	155T	E229803
3.4	TAPE 胶带	JY312V/微黄色	FUZHOU MAILADUONA ELECTRIC MATERIAL CO.LTD	130C	E188295
3.5	SOLDER 锡	107H	THOUSAND ISLAND METAL FOIL Co.,LTD	420C	
3.6	VARNISH 凡立水	1032C.L1	SHENZHEN MINGSHUNJIE TECHNOLOGY CO.,LTD		E213473



**7.0 Illustrations**

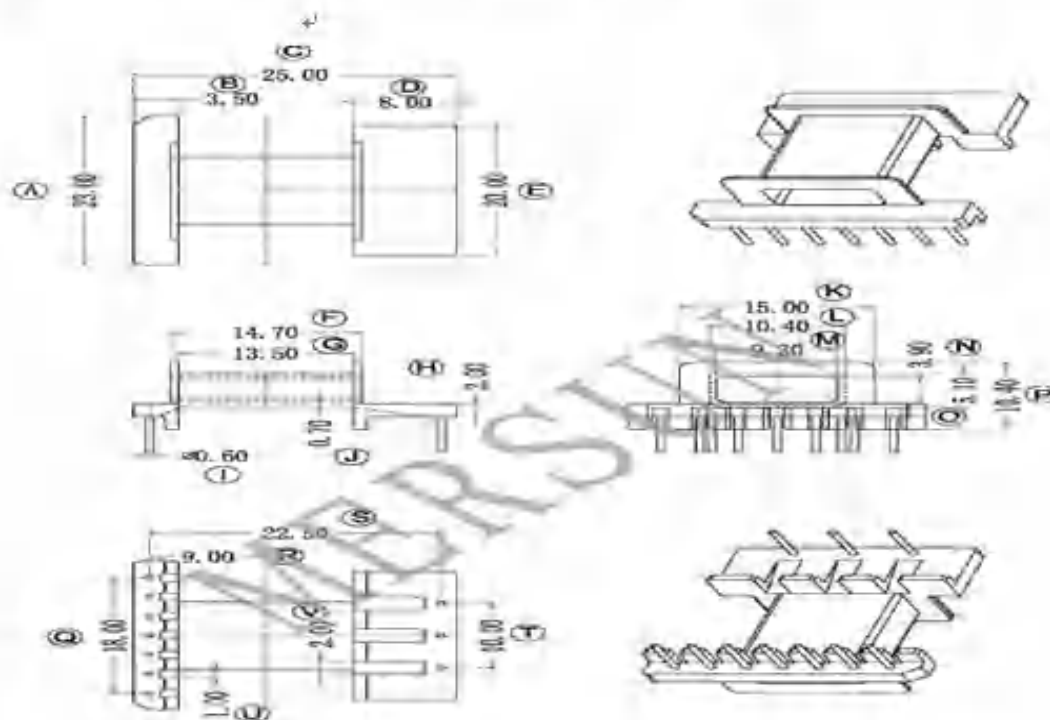
**Illustration 73 - PCB Layout diagram for LED Driver model TR-030**



**7.0 Illustrations**

**Illustration 74 - Transformer T1 Specification for model TR-030.**

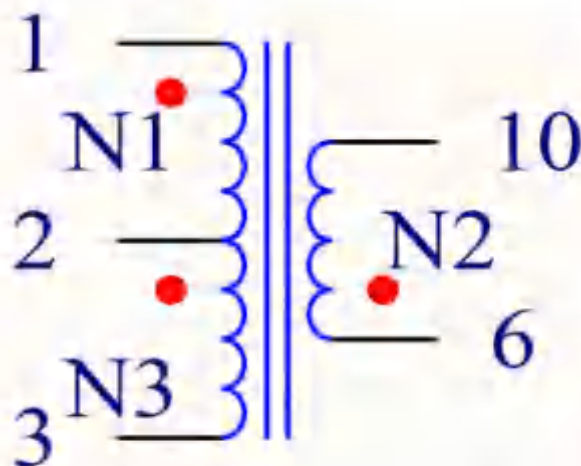
**一、外观结构图 Overall dimensions diagram (units:mm)**



备注：+

- 1.成品真空浸油漆烘干处理。+
- 2.空 1.5.6.7.8.9.11.13.14 脚，3 脚绕线后剪余头、成品底部磁芯需要加底座、加强绝缘。+

**二、绕线数据 Electrical schematic diagram:**



序号	绕组	起绕-终绕	线 径	圈数	绕 法	胶 带
1	N1	3-2	2UEWΦ 0.27*1P	40	密绕	2TS
2	N2	10-6	TILW-52 Φ0.4*1P 三层 绝缘线	54	密绕	2TS
3	N3	2-1	2UEWΦ 0.27*1P	46	密绕	2TS

**7.0 Illustrations**

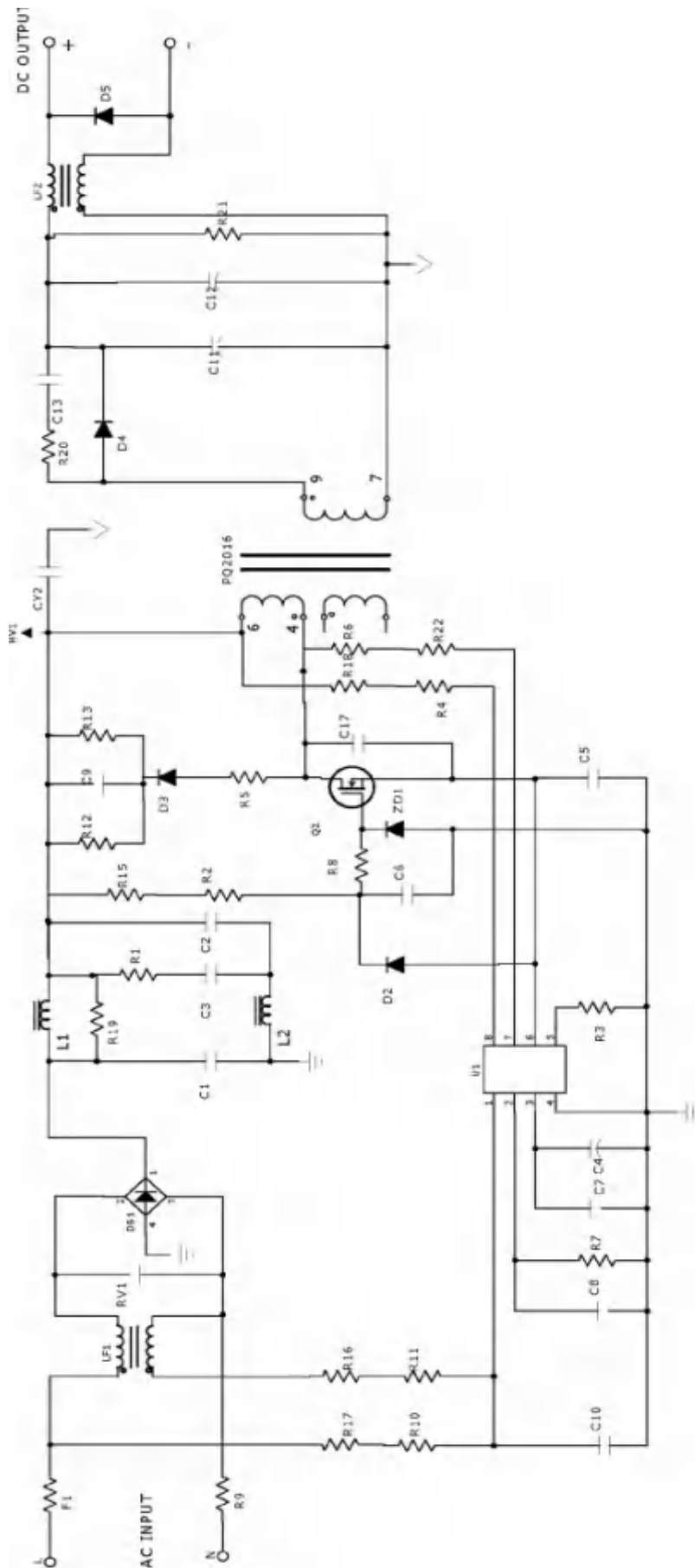
**Illustration 75 - Transformer T1 Specification for model TR-030.**

四、结构图及材料 Structural diagram and materials.  
 (-) 材料清单(见下表)

NO	ITEM	MATERIAL	SUPPLIER OR MANUFACTURER	CLASS	DL NO
3.1	CORE磁芯	EE16/15N-PC44	GUANGWANG ELECTRONICS CO. LTD		
3.2	BORON骨架	EE16/15-3D一体式单边加宽 IT-100/B	CHANG CHEN PLASTIC CO. LTD.	L30C	E15948
3.3	WIRE线材	X-LINE 0.15mm Q&A 0.155	WE HU COPPER COIN ELECTRICITY LTD	150T	E16170
		0.2mm-52.155(F)	TAIYU ELECTRIC WIRE & CABLE CO. LTD	153 D	E16580
3.4	TAPE胶带	JV J10V 淡黄色	SUNHOU AIAI ADONVA ELECTRIC MATERIAL CO. LTD	L30T	E155195
3.5	TUBE套管	Color Recognized	SHENZHEN WUER HEAT-SHRINKABLE MATERIAL CO. LTD	600V 125C	E183950
3.6	VARNISH凡 立水	HR1111	SHENZHEN MINGSHUNTE TECHNOLOGY C. O. LTD		E113473

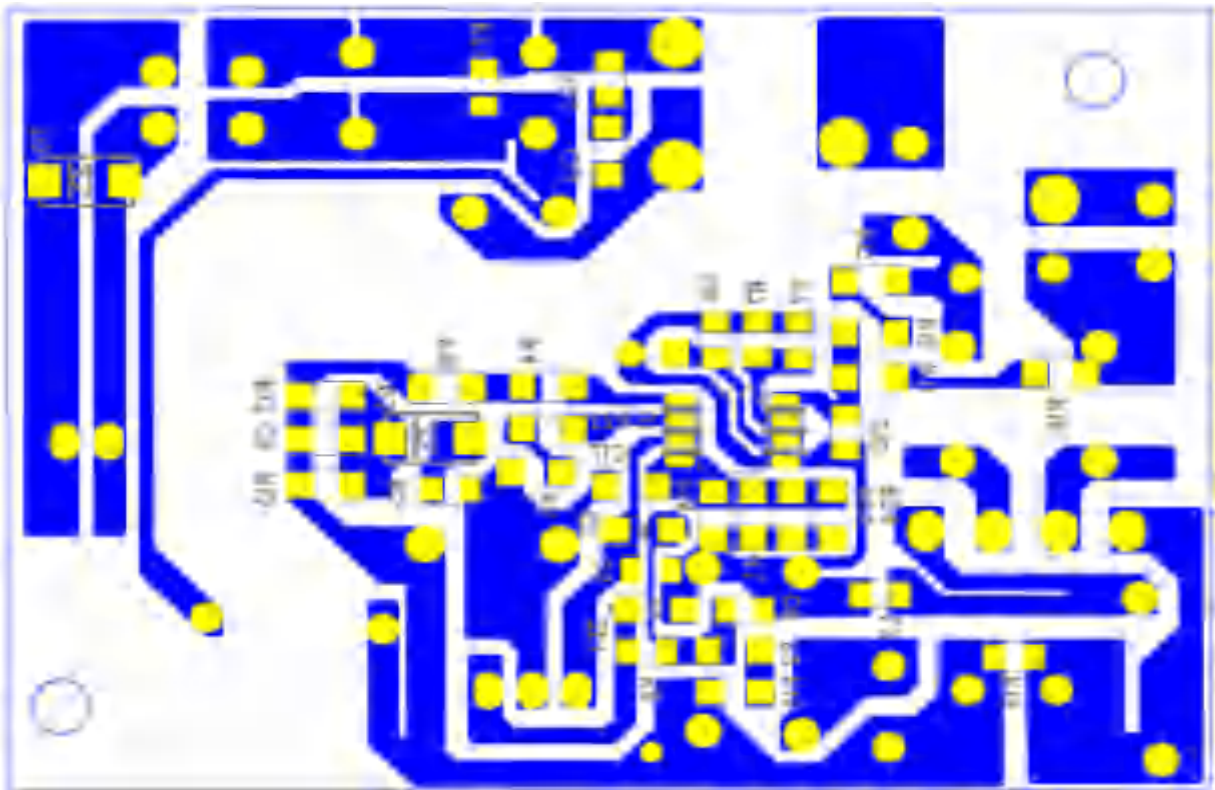
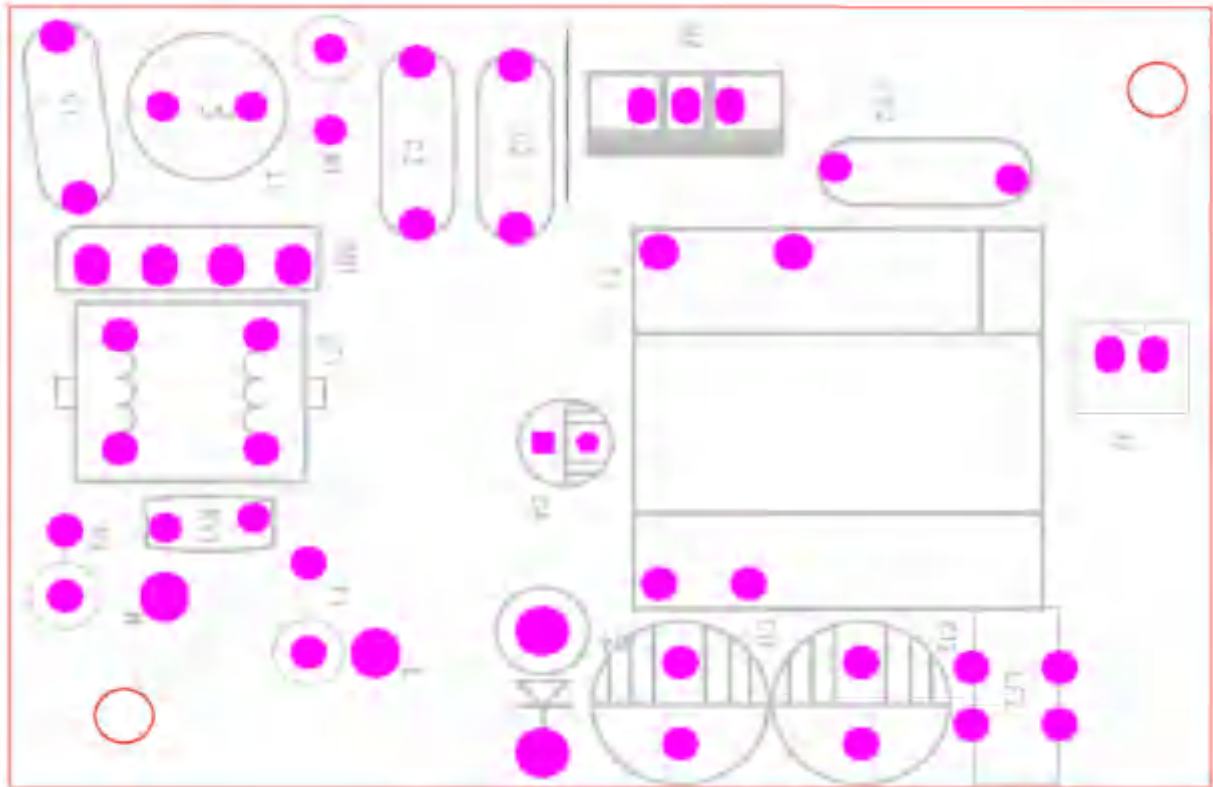
**7.0 Illustrations**

**Illustration 81a** - Circuit diagram for LED Driver model TR-031A



**7.0 Illustrations**

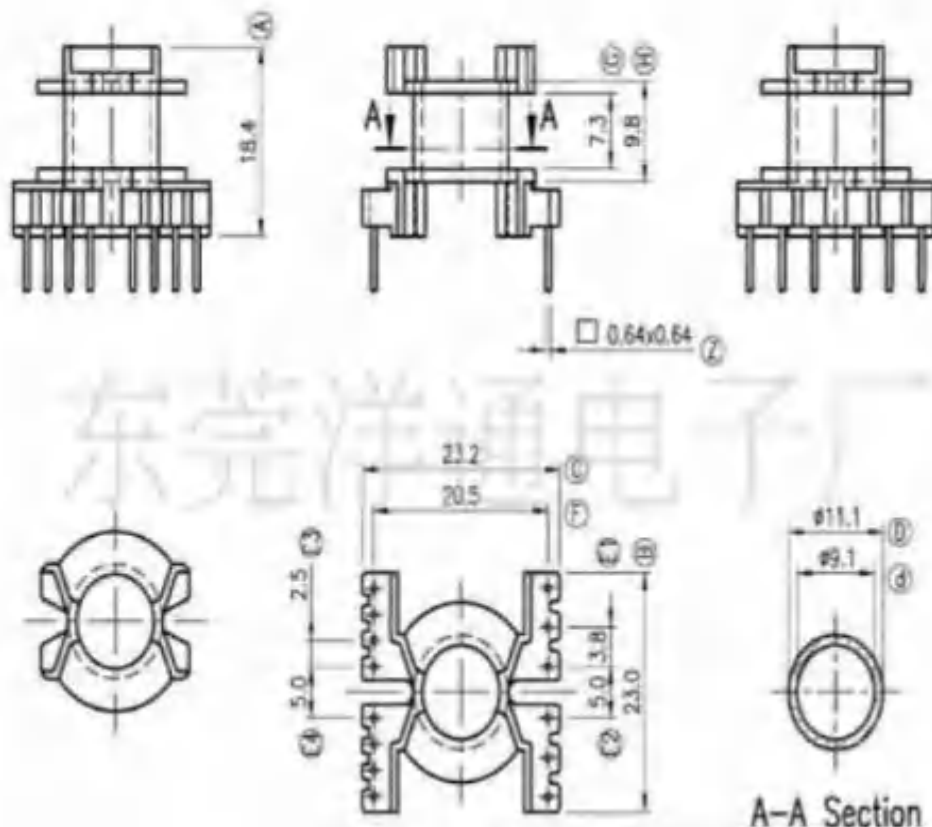
**Illustration 82a** - PCB Layout diagram for LED Driver model TR-031A



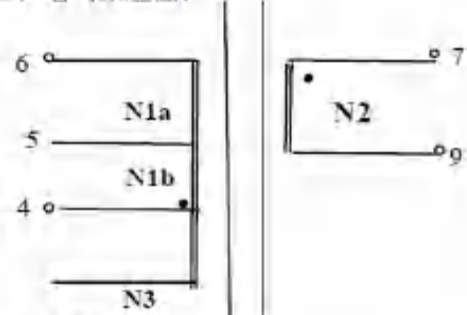
**7.0 Illustrations**

**Illustration 84a** - Transformer T1 Specification for model TR-031A

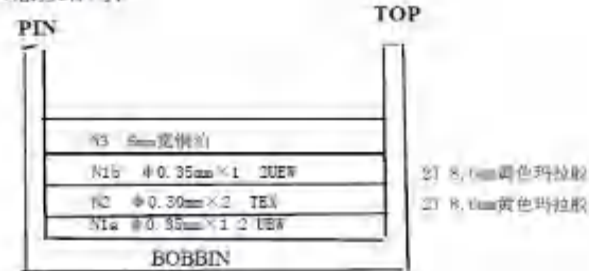
一、外形、结构 (单位: mm)



二、电气原理图:



三、绕组结构:



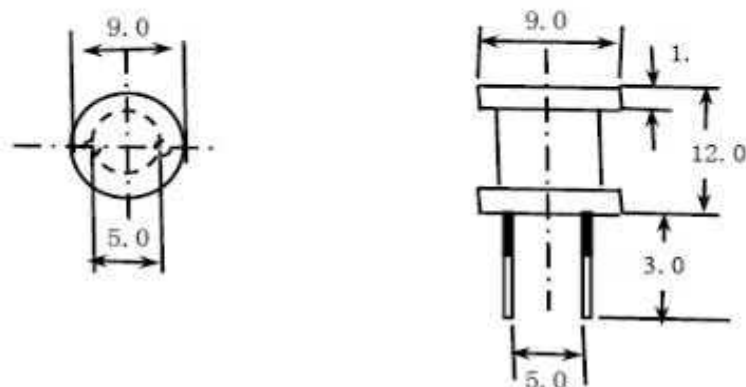
四、绕制顺序:

序号	绕序	相位	线径	圈数	隔层胶带	编制方式
1、	N1a	6→5	φ0.35mm×1.2 UEW	26TS	2TS	密绕
2、	N2	9→7	φ0.30mm×2 TEX 三层绝缘线	22TS	2TS	密绕
3、	N1b	5→4	φ0.35mm×1.2 UEW	28TS	2TS	密绕
4、	N3	4→NC	COPPER 6mm	0.9TS	2TS	

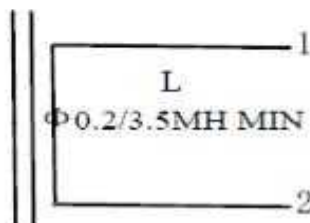
**7.0 Illustrations**

**Illustration 84c** - Specification of Inductor (L1) for LED Driver model TR-031A

**1. CONFIGURATION & DIMENSION: (UNIT:mm)**

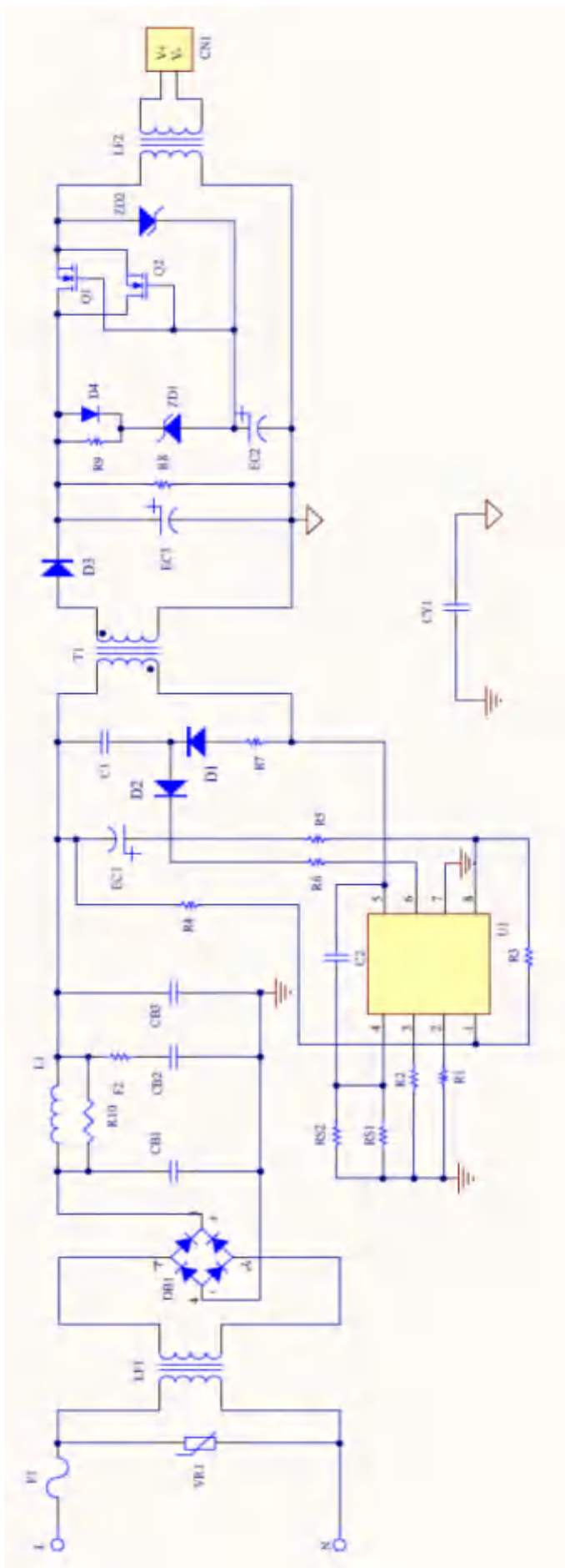


**2. SCHEMATIC:**



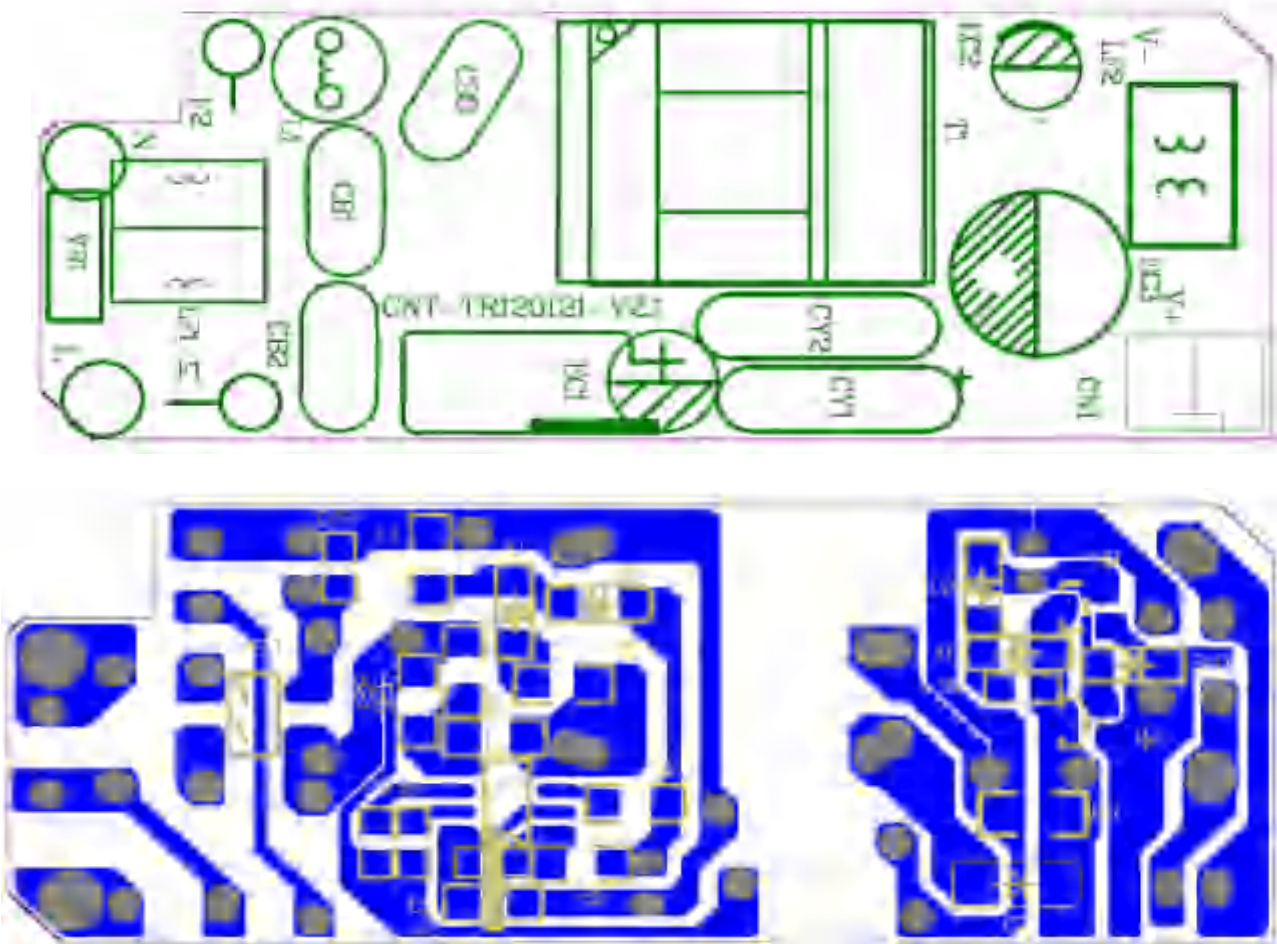
**7.0 Illustrations**

**Illustration 85 - Circuit diagram for LED Driver model TR120A and TR120B**



**7.0 Illustrations**

**Illustration 86** - PCB Layout diagram for LED Driver model TR120A and TR120B



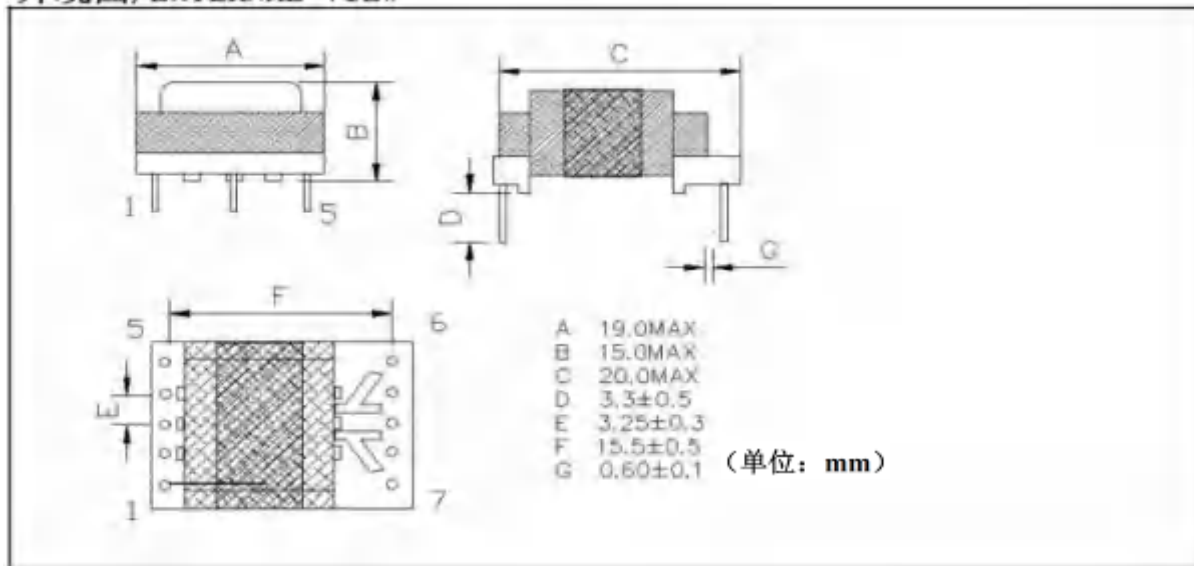
**Illustration 86a** - Model difference between LED Driver TR120A and TR120B

Model No.	Transformer T1
TR120A	EE1608
TR120B	EE16

**7.0 Illustrations**

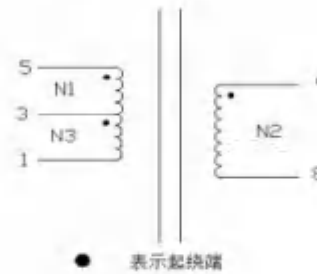
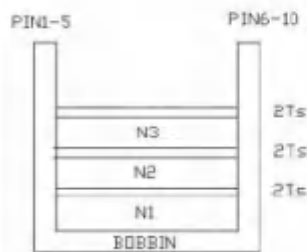
**Illustration 87 - Transformer T1 Specification for LED Driver model TR120A**

**外观图/EXTERNAL VIEW**



**SCHEMATIC:**

**CONNECT:**

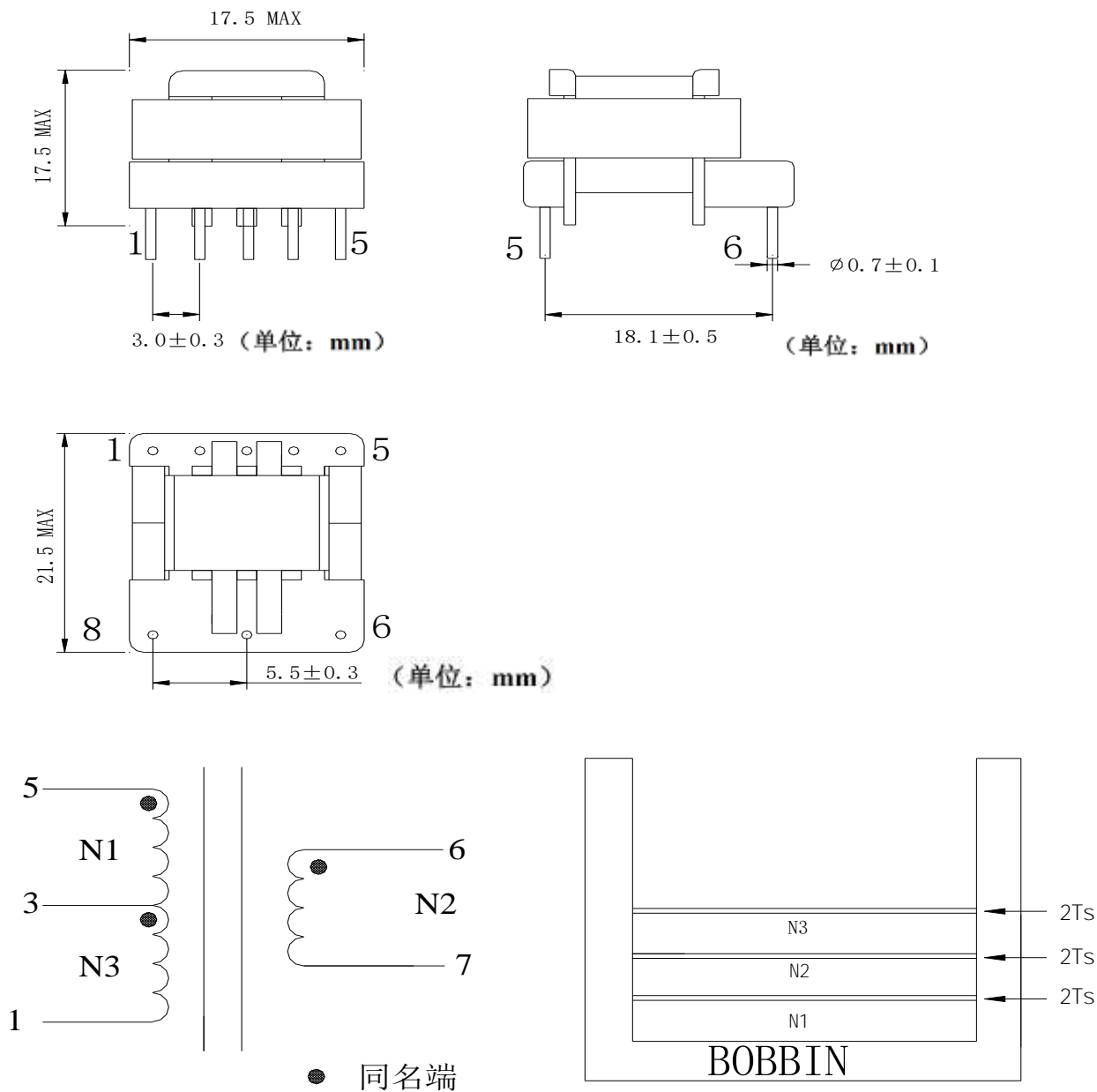


**绕线结构/WINDING STRUCTURE**

WDG	Pin S-F	Material	Turns	Tape	TUBE		Remarks
					BEGIN	FINISH	
N1	5-3	21EV-4Φ0.18mm*1P	80 TS	2TS*8.8mm			PIN1-5(0V) 前绕
N2	6-8	21W-B Φ0.23mm*1P	46 TS	2TS*8.8mm			PIN1-5(0V) 后绕
N3	3-1	21EV-4Φ0.18mm*1P	74 TS	2TS*8.8mm			PIN1-5(0V) 前绕

**7.0 Illustrations**

**Illustration 88 - Transformer T1 Specification for LED Driver model TR120B**

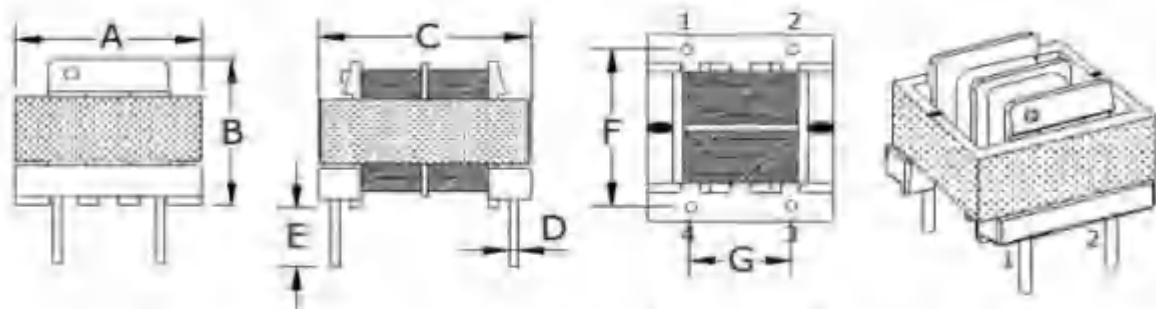


NO	STEP	Start - Finish	WIRE (mm)	TURNS(TS)	MILAY TAPE (mm)	REMARKS
1	N1	5-3	(2UEW) $\phi 0.18^*1P$	70TS	7.8mm*2TS	同层
2	N2	6-7	(TEX-E) $\phi 0.35^*1P$	40TS	7.8mm*2TS	同层
3	N3	3-4	(2UEW) $\phi 0.18^*1P$	30TS	7.8mm*2TS	同层

**7.0 Illustrations**

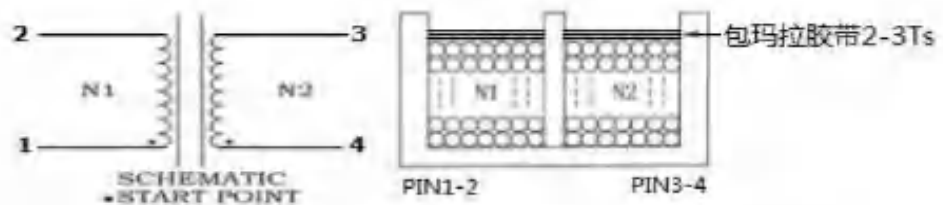
**Illustration 89** - Specification of Inductor (LF1) for LED Driver model TR120A and TR120B

**1. 外型尺寸图 (单位: mm)**



A	B	C	D	E	F	G
10.0(Max)	10.0(Max)	10.0(Max)	Ø0.5±0.1	3.5±0.5	6.8±0.5	5.0±0.5

**2. 原理图**



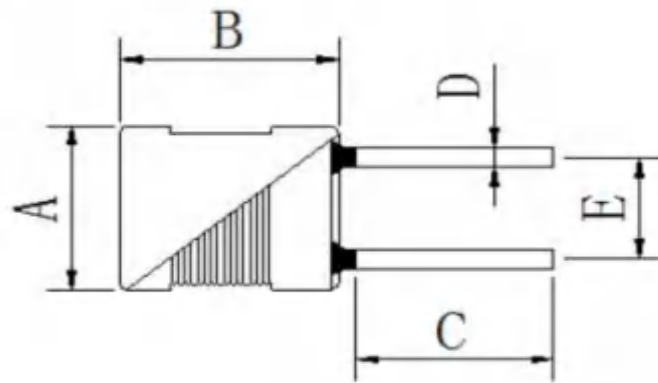
**3. 绕制工艺**

层次	S	F	线径&根数	圈数	绕线方式	需否包黄胶带
N1	1	2	Φ0.15x1C	85 Ref	密绕	需要
N2	4	3	Φ0.15x1C	85 Ref	密绕	需要

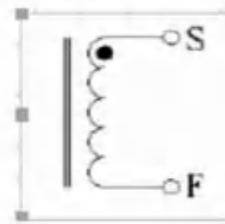
**7.0 Illustrations**

**Illustration 90** - Specification of Inductor (L1) for LED Driver model TR120A and TR120B

1. 构造尺寸:



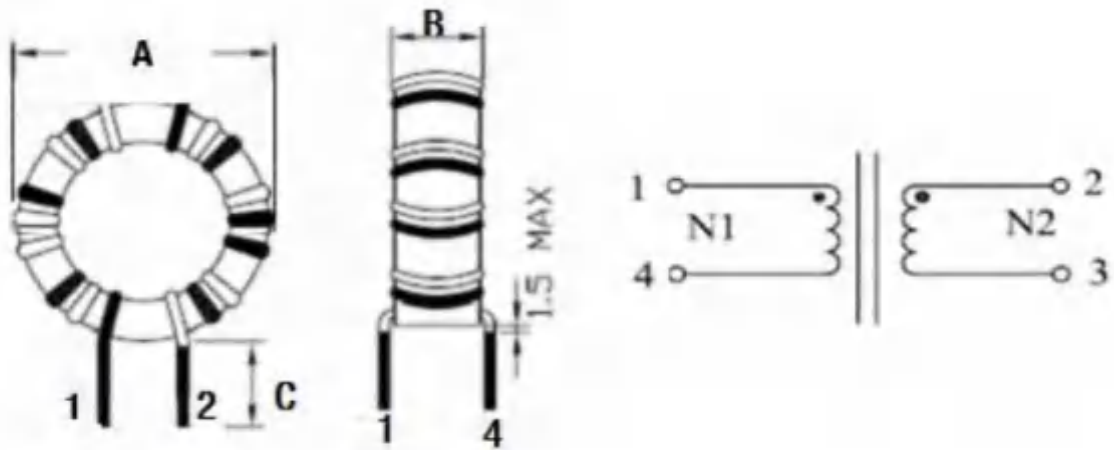
2. 电性图



0.12MM\*1P\*275TS

**7.0 Illustrations**

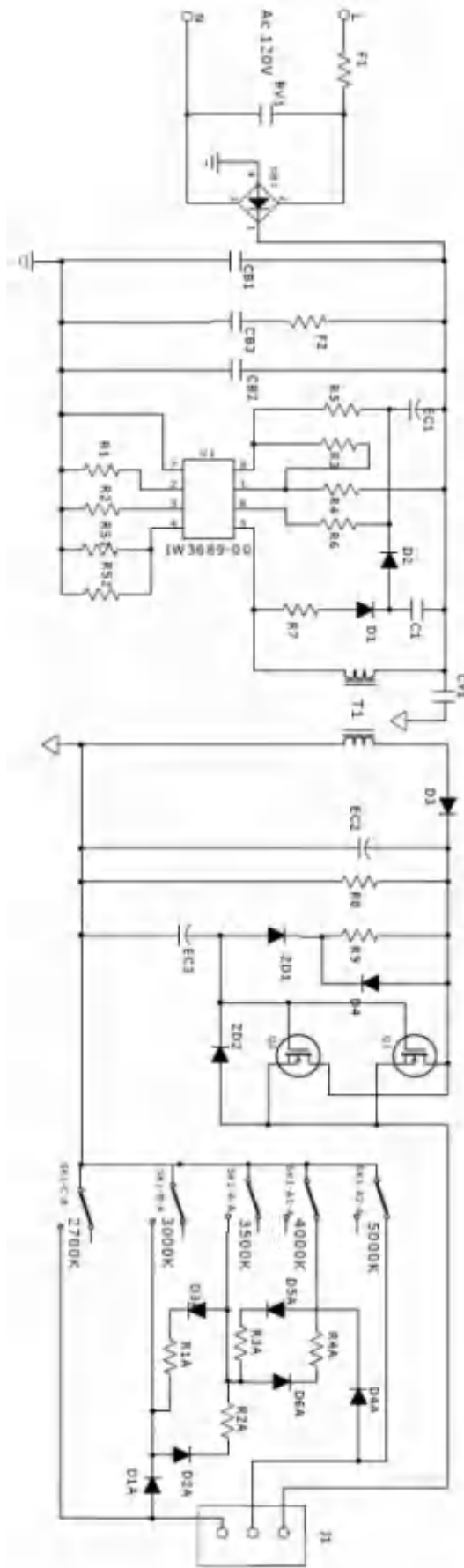
**Illustration 91** - Specification of Inductor (LF2) for LED Driver model TR120A and TR120B



No.	STAR	FINISH	WIRE	COLOR	TURNS	INDUCTANCE
N1	1	2	0.4mm	N	15T5	1500uH
N2	4	3	0.4mm (紅包)	N	15T5	1500uH

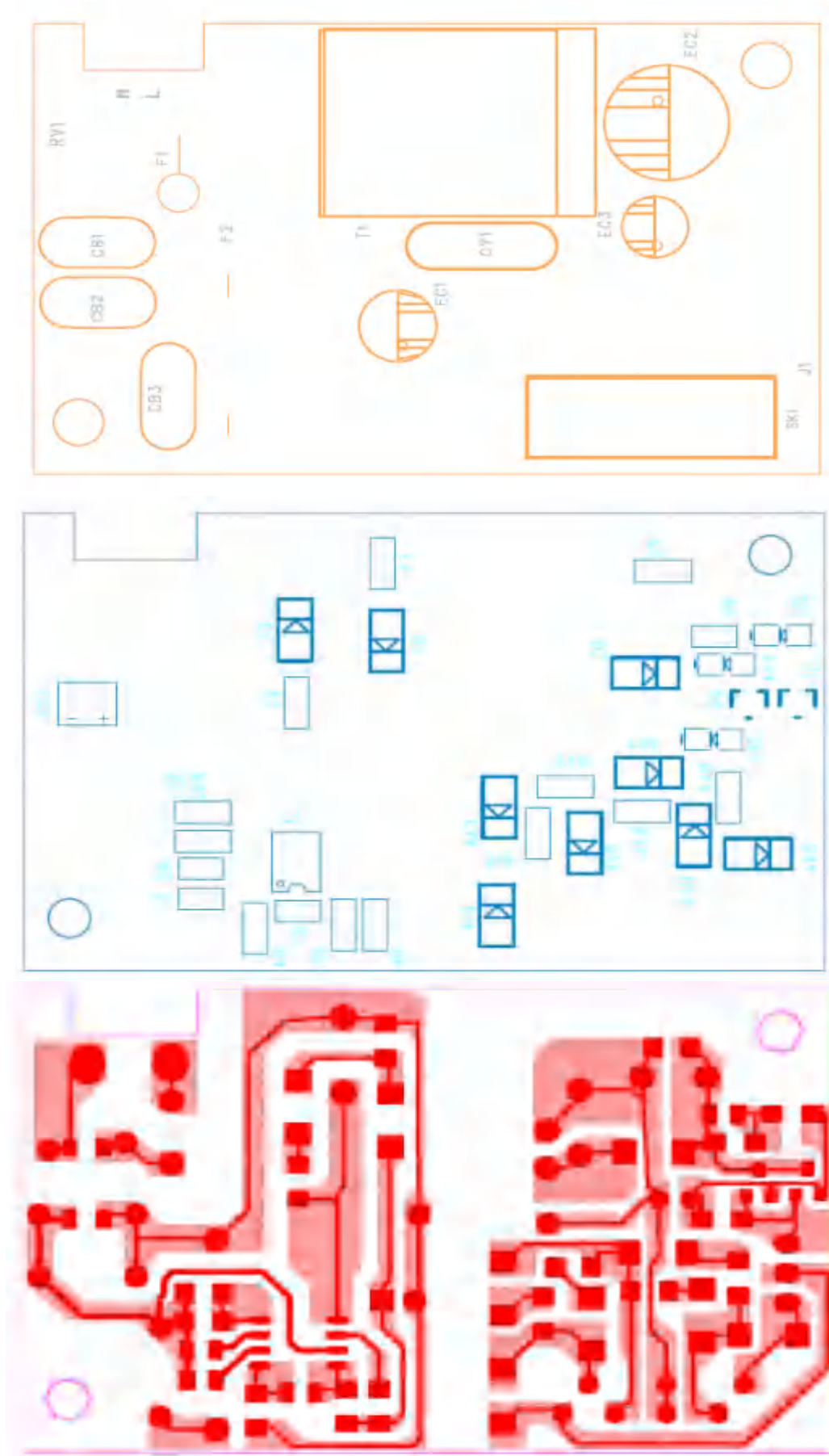
**7.0 Illustrations**

**Illustration 92 - Circuit diagram for LED Driver model TR125**



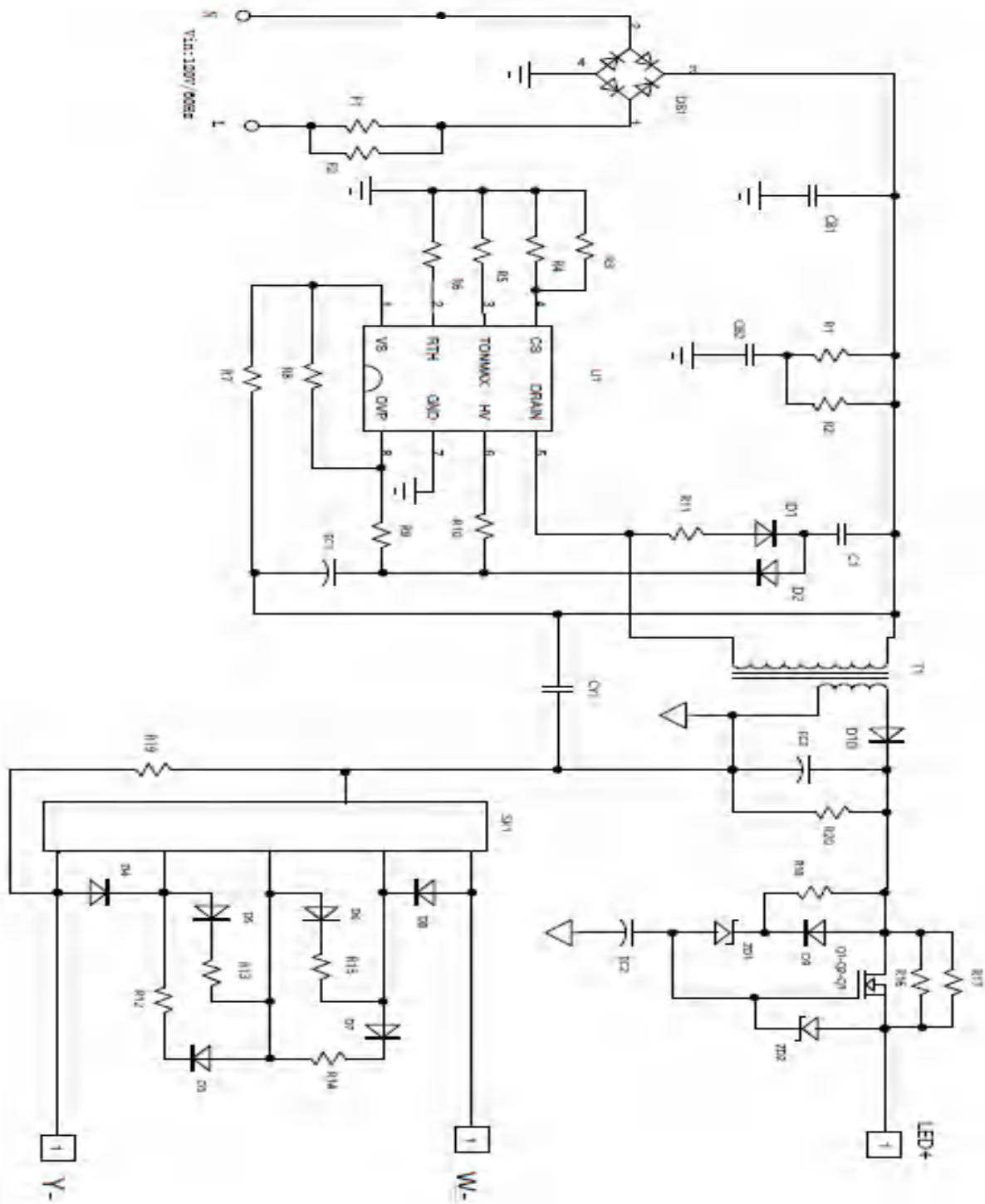
**7.0 Illustrations**

**Illustration 93 - PCB Layout diagram for LED Driver model TR125**



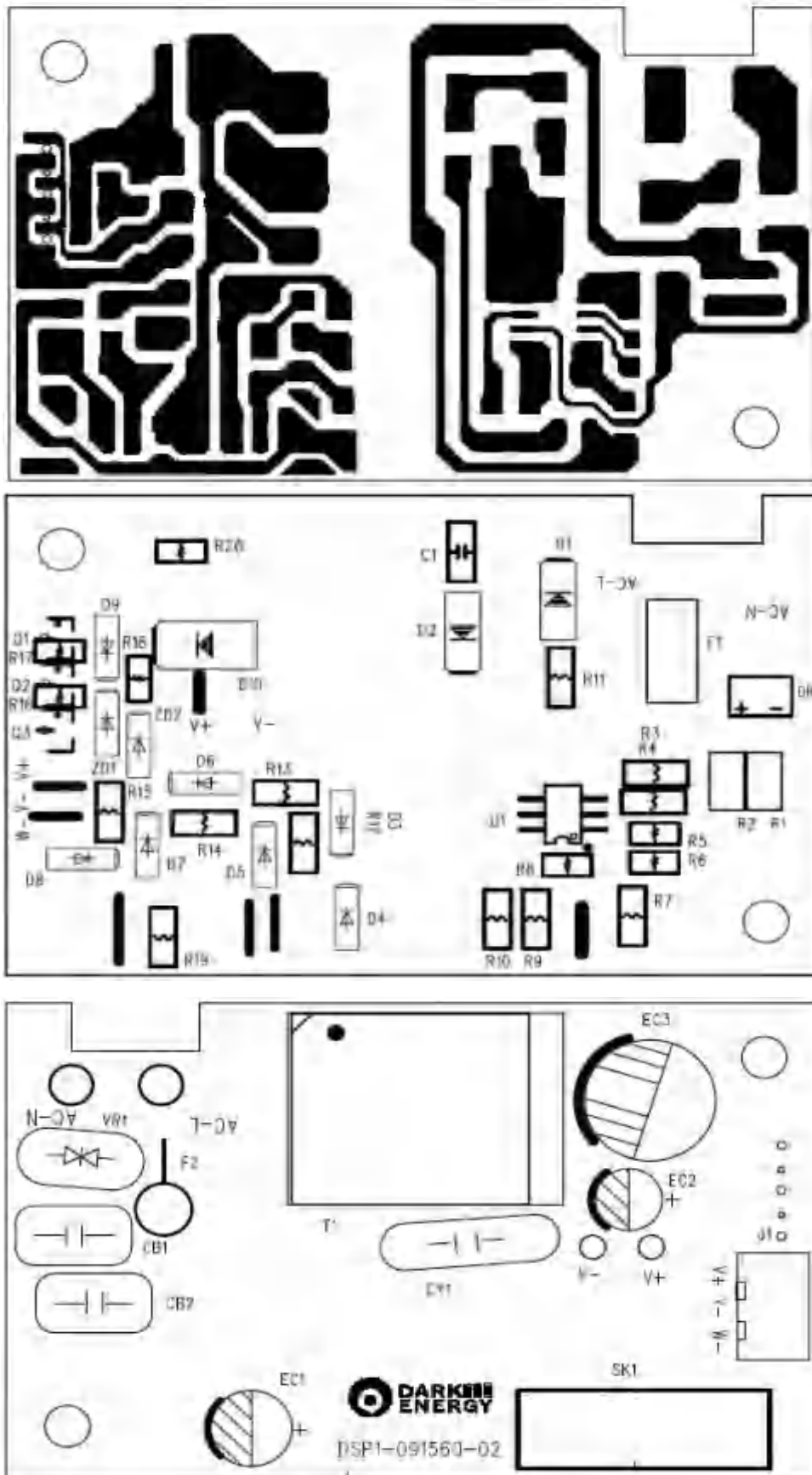
**7.0 Illustrations**

**Illustration 93a** - Circuit diagram for LED Driver model TR-063



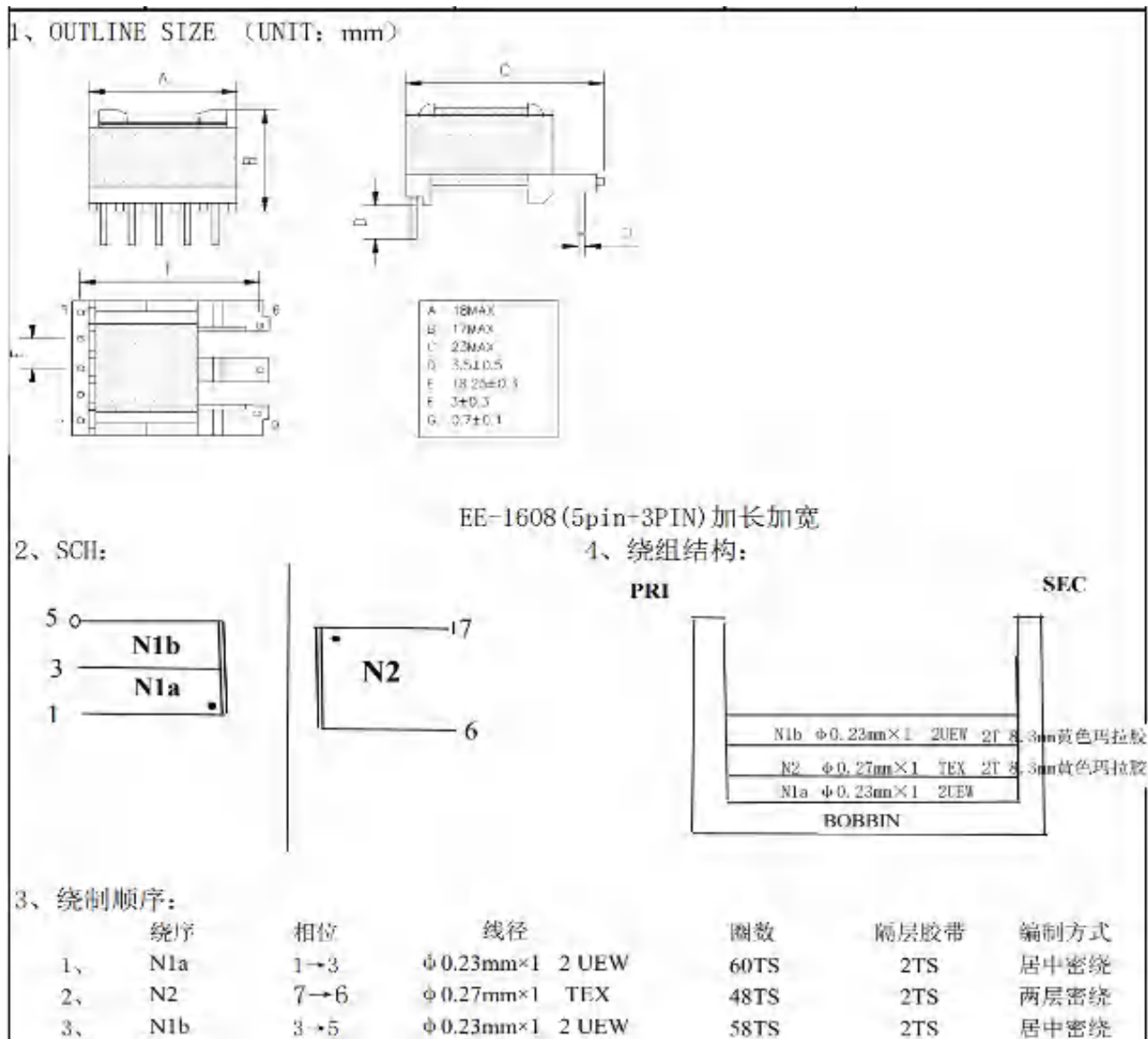
**7.0 Illustrations**

**Illustration 93b** - PCB Layout diagram for LED Driver model TR-063



**7.0 Illustrations**

**Illustration 94 - Transformer T1 Specification for LED Driver models TR-125 and TR-063**



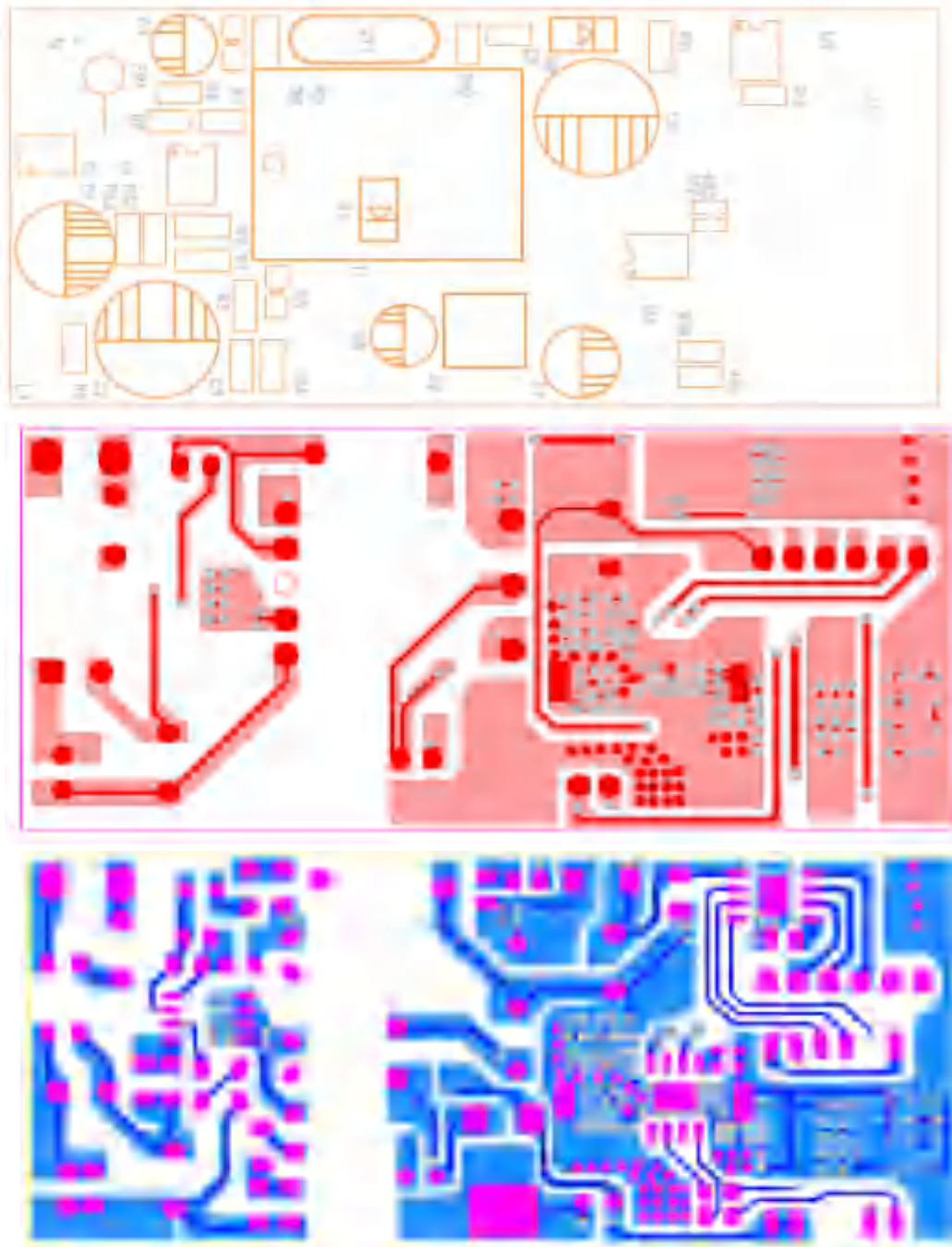


**7.0 Illustrations**

**Illustration 95a** - Components difference between LED Driver model TR-053 and TR-054

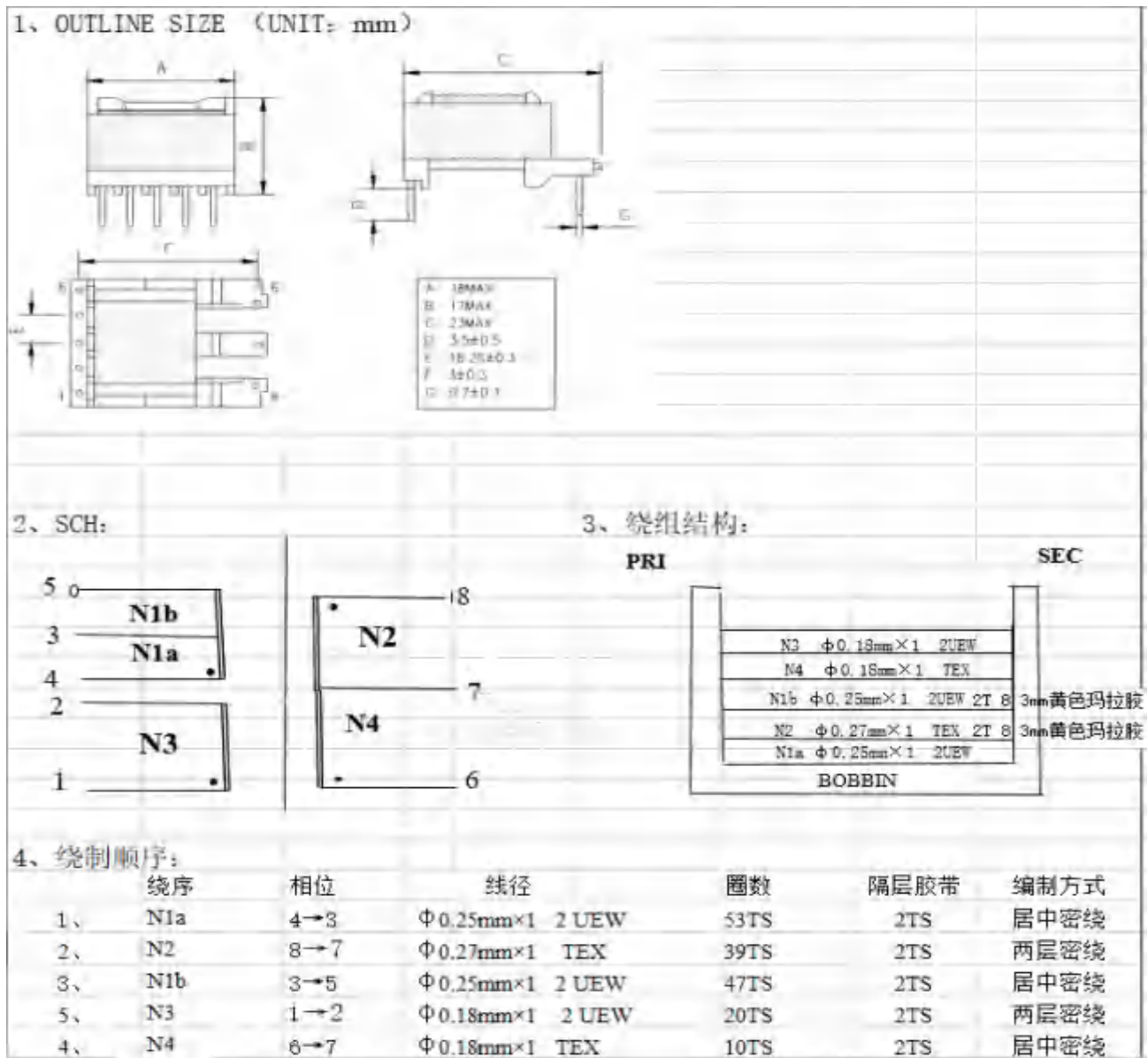
Model difference			
Model No	Transformer T1	C1	IC U3 is covered with heat sink or not
TR-053	JY-TR053-10W	6.8uF/400V	No
TR-054	JY-TR054-12W	10uF/400V	Yes

**Illustration 96** - PCB Layout diagram for LED Driver model TR-053 and TR-054



**7.0 Illustrations**

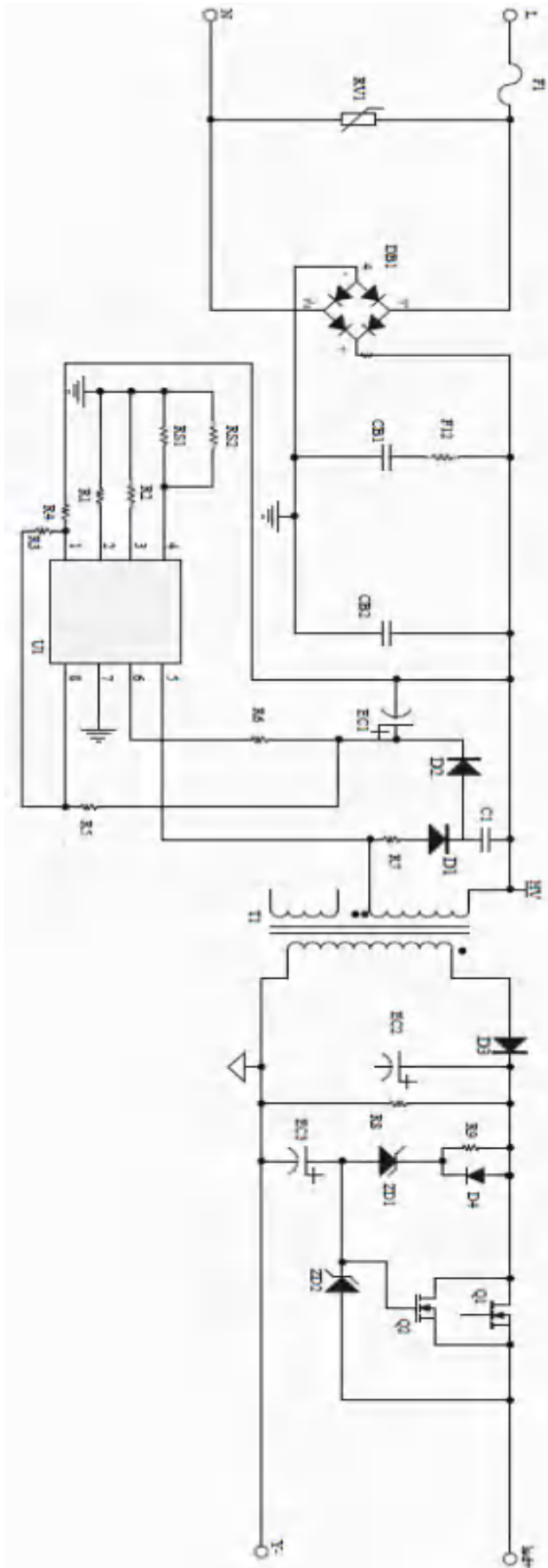
**Illustration 97 - Transformer T1 Specification for LED Driver model TR-053**





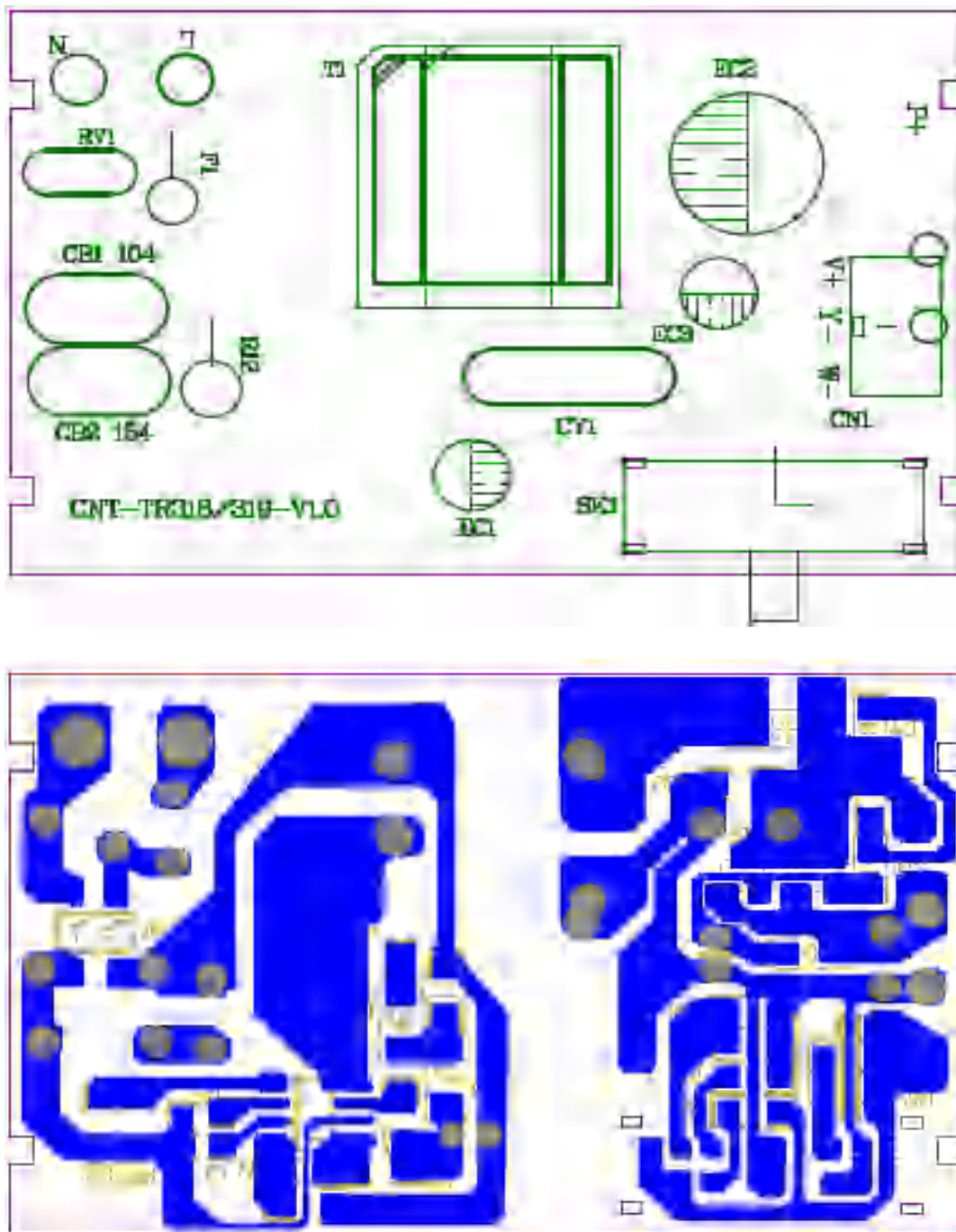
**7.0 Illustrations**

**Illustration 99** - Circuit diagram for LED Driver model TR-319



7.0 Illustrations

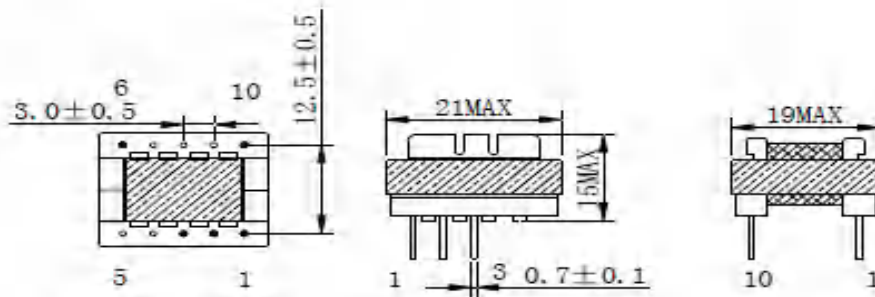
Illustration 100 - PCB Layout diagram for LED Driver model TR-319



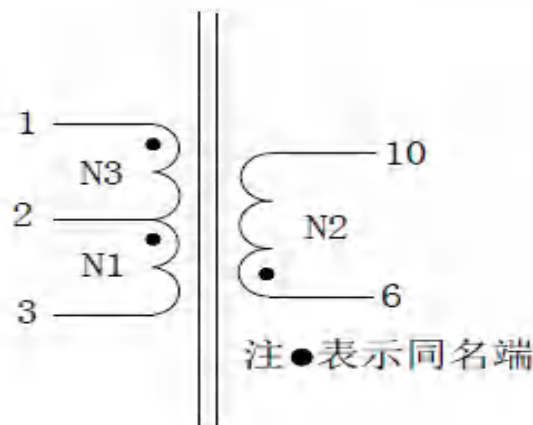
**7.0 Illustrations**

**Illustration 101 - Transformer T1 Specification for LED Driver model TR-319**

外观尺寸图 (单位: mm)



电路原理图

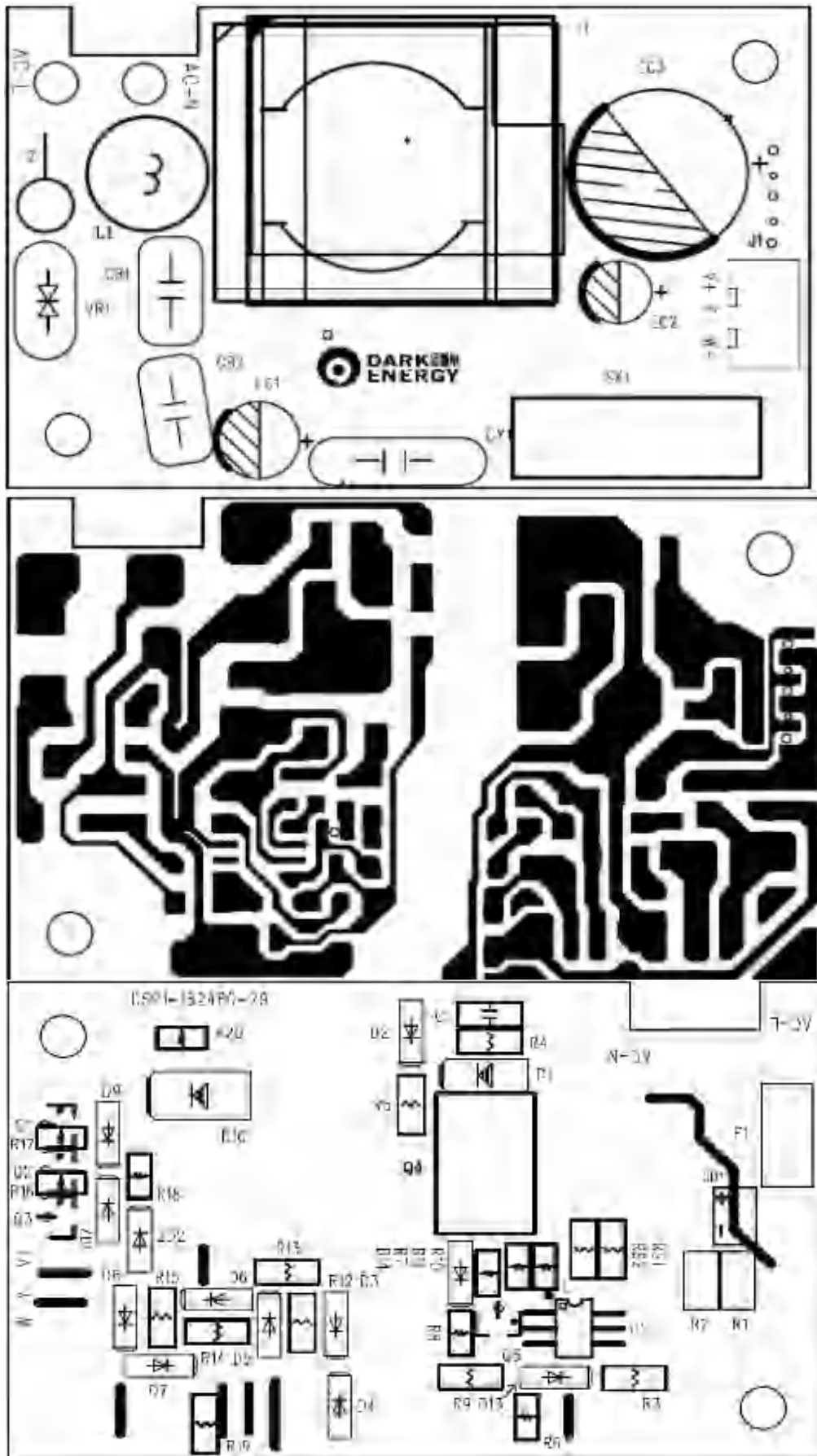


序号	材料	材质型号	厂商	UL 认证号码
1	骨架	T375J/UL94	CHANG CHUN PLASTICS CO LTD 长春人造树脂厂股份有限公司	E59431
2	磁芯	FC40/EE19 ±210℃	HAINING LINGTONG MAGNETIC INDUSTRY TECHNOLOGY CO LTD 海宁凌通磁性科技有限公司	(SGS)
3	铜线	DUEWF-155℃	SIHUI HENGHUI ELECTRICAL APPLIANCES CO LTD 四会市恒辉电工器材有限公司	E337946
			DONGGUAN HAOKE ELECTRONICS TECHNOLOGY CO LTD 东莞市浩科电子科技有限公司	E319387
			ZHEJIANG HONGBÓ TECHNOLOGY CO LTD 浙江洪波科技股份有限公司	E331719
4	玛拉胶布	TY-130℃	DONGGUAN BLEM ELECTRONIC TECHNOLOGY CO LTD 东莞贝莱尔纳电子科技有限公司	E490647
5	绝缘漆 稀释剂	E962	ZHUHAI CHANGXIAN NEW MATERIALS TECHNOLOGY CO LTD 珠海长先新材料科技股份有限公司	E335405
6	锡膏	Sn99.3/Cu0.7	云南锡业股份有限公司 Yunnan Tin Co., Ltd.	(SGS)
7	三层绝缘线	TIWB-130℃	DONGGUAN GUANGDING ELECTRONIC TECHNOLOGY CO LTD 东莞广鼎电子科技有限公司	E315265



7.0 Illustrations

Illustration 103 - PCB Layout diagram for LED Driver model TR-062



**7.0 Illustrations**

**Illustration 104 - Transformer T1 Specification for LED Driver model TR-062**

客户 CUSTOMER	明能集	客户料号 MATERIAL NO.	126-PQ2016 DU90-2011E1-00	版本 REV	A
品名 MODEL NO.	PQ2016变压器	同华料号 OUR PART NO.	PQ20KS099-ANL	日期 DATE	2022-11-14

1. 结构尺寸图(单位: mm) DIMENSION

正视图

侧视图

底视图

136-PQ2016  
HH YYWW

注意事项:

- PIN朝外顺时针绕线, PQ2016 6+8骨架空, 6, 7, 8, 9, 11, 12脚. PIN2脚剪掉2/3, PIN4脚保留.
- 线包胶套用0.2mm浅黄胶带, 绕线时线要拉紧, 平整, 均匀, 漆包层不可脱落或破损.
- 磁芯气隙装顶部, 用0.2mm浅黄胶带包3TS.
- 产品需真空浸油.
- 标签贴于顶部1-6边正面.

2. 原理图/CIRCUIT DIAGRAM

3. 内部结构图/CONSTRUCTION DIAGRAM

3. 绕线结构

绕组	PIN脚	绕线方向 (PIN1脚)	套管		漆包线规格	圈数 (TS)	胶带 (TS)	备注
			S	F				
N1	4-2				20EW Φ0.25*1P	27	2T	密绕1层 隔离交叉
N2	10-13				20EW Φ0.35*1P	34	2T	密绕2层
N3	2-3			套管	20EW Φ0.25*1P	35	2T	密绕2层
N4	1-5			套管	20EW Φ0.2*2P	31	2T	密绕2层

**7.0 Illustrations**

**Illustration 104a - Inductance L2 Specification for LED Driver model TR-062**

一、电气特性:

序号	测试项目	测试脚位	测试条件	测试范围
1	电感	S-F	L: 100Hz, 0.25V (25℃)	2.5mH ±10%
2	电阻	S-F		23.5Ω MAX
3				
4				
5				
6				

二、外型、结构 (单位: mm)

DIMENSION (mm)	
A:	10 MAX
B:	13 MAX
C:	1.0±0.1
D:	0.4±0.1
E:	0.6±0.1
F:	
G:	
H:	

三、原理图:

四、绕线工艺

Item	Winding	Terminal	Tuns	Wire	REMARKS
1	N1	S-F	273TS (REF)	2UEW Φ0.20mm*1P	均匀密绕

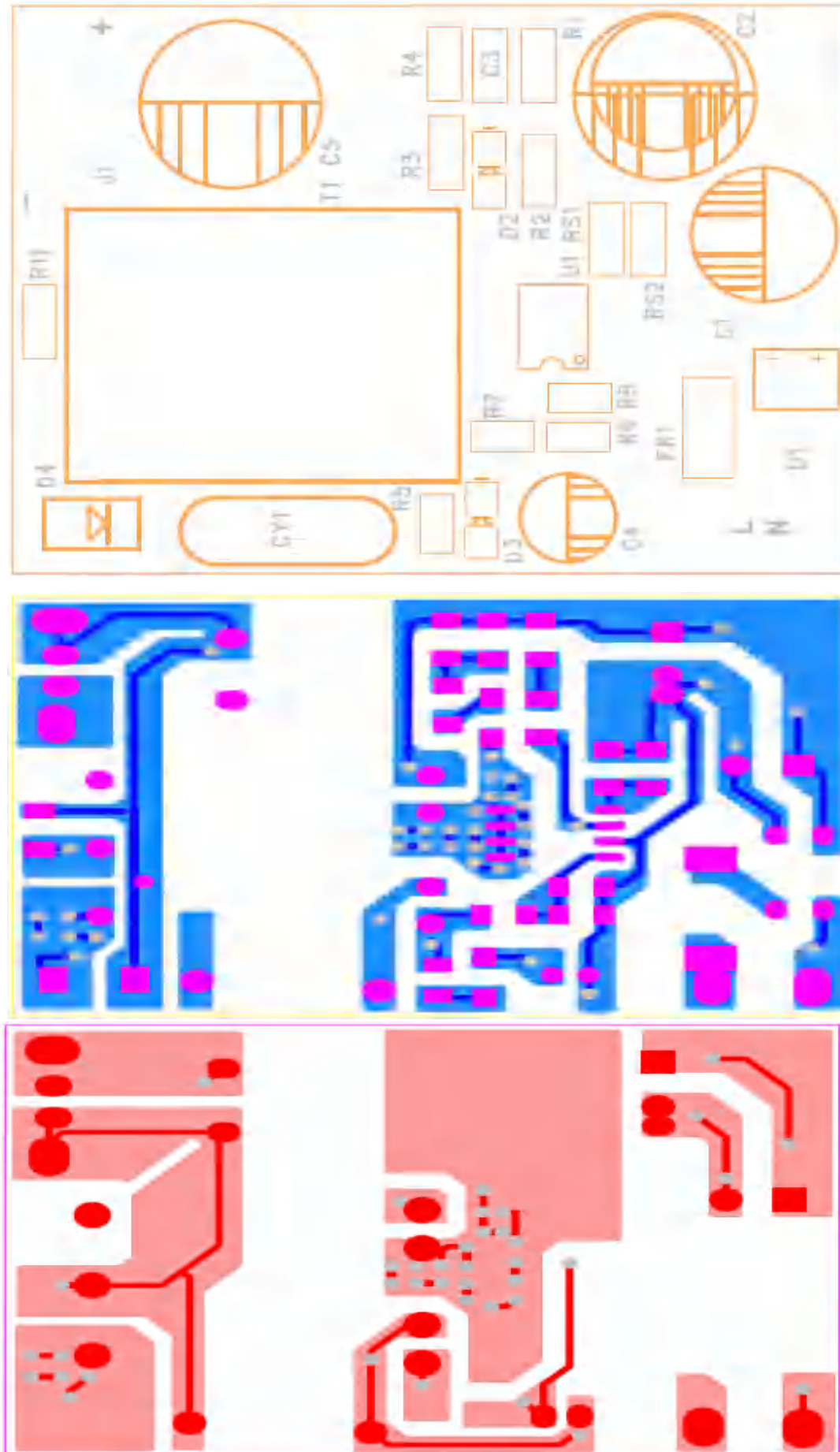
五、材料清单:

序号	材料名称	材质规格	用量	供应商	备注
1	CORE	DR2W 8x10 B=0.5		HONGHANG	
2	WIRE	2UEW 150℃ Φ0.20mm 漆包铜圆线		TONGLING	
3	TIN	1P		ZhengShi	
4	TUBE	Φ0.8		WSP	



7.0 Illustrations

Illustration 106 - PCB Layout diagram for LED Driver model TR-054B



**7.0 Illustrations**

**Illustration 107 - Transformer T1 Specification for LED Driver model TR-054B**

机种	EE1608TR054B分体	DATE	2022/9/29	RVE	A/0
MODEL	EE1608TR054B分体	NAME	变压器原理图	CORE	EE-1608(5+3pin)

1、OUTLINE SIZE (UNIT: mm)

EE-1608(5pin+3PIN) 加长加宽

2、SCH:

四、绕组结构:

五、编制顺序:

顺序	匝数	相位	线径	圈数	隔层胶带	编制方式
1、	N1a	4→3	φ0.25mm×1 2 UEW	53TS	2TS	层中密绕
2、	N2	3→7	φ0.27mm×1 2 TEX	45TS	2TS	两层密绕
3、	N1b	3→6	φ0.25mm×1 2 UEW	47TS	2TS	层中密绕
5、	N3	1→2	φ0.18mm×1 2 UEW	20TS	2TS	两层密绕

六、电性参数:

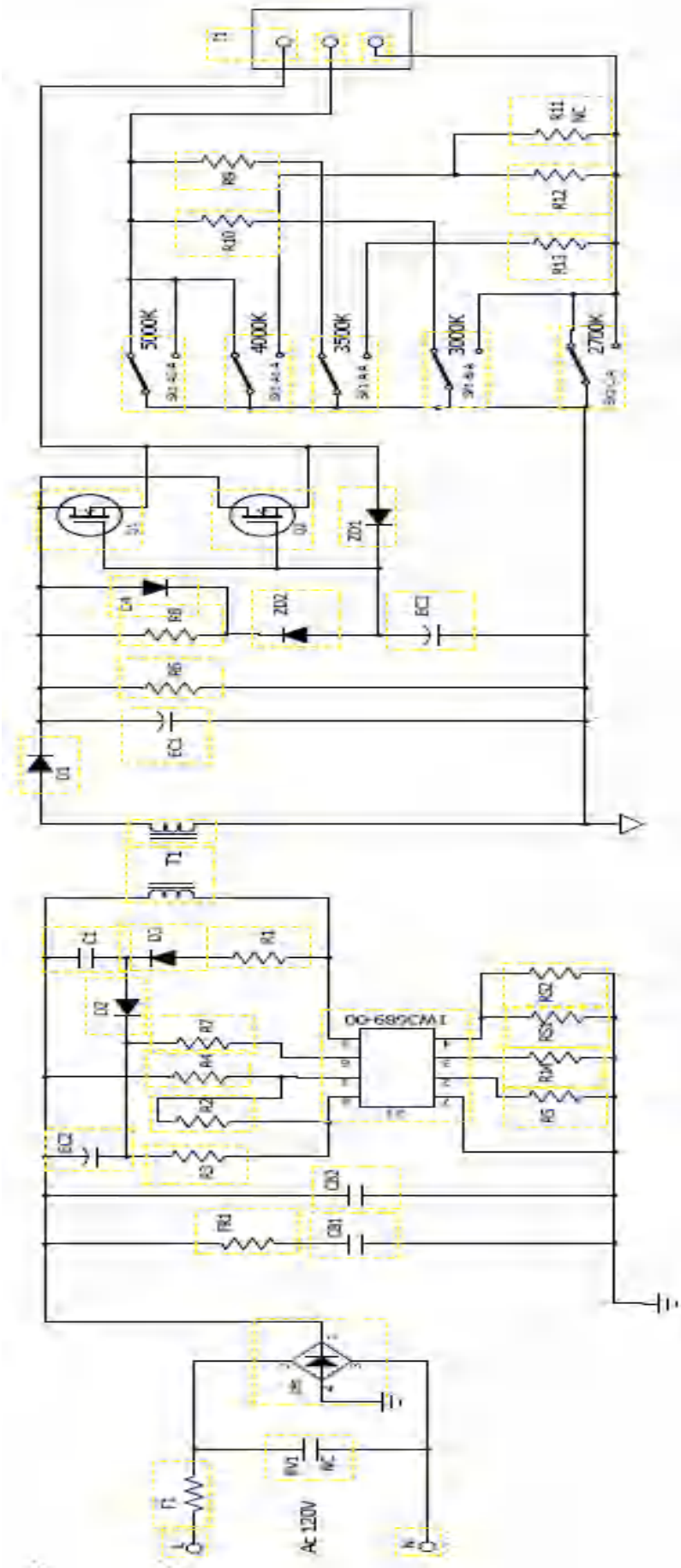
- INDUCTANCE TEST (10KHz 电桥串联测试)  
 $L(5-4)1.7-1.9mH$  /  $LK(5-4):50uH-max$
- HI-POT TEST:  
 P-S:AC1000V/2mA FOR 1 MIN  
 P-C:AC1000V/2mA FOR 1 MIN  
 S-C:AC1000V/2mA FOR 1 MIN

七、工艺要求:

- 真空浸漆, EE1608磁芯(CORE: PC40或等材料) UL ROHS
- 3PIN OUT OUT,
- 外面贴标签 EE1608TR054B分体

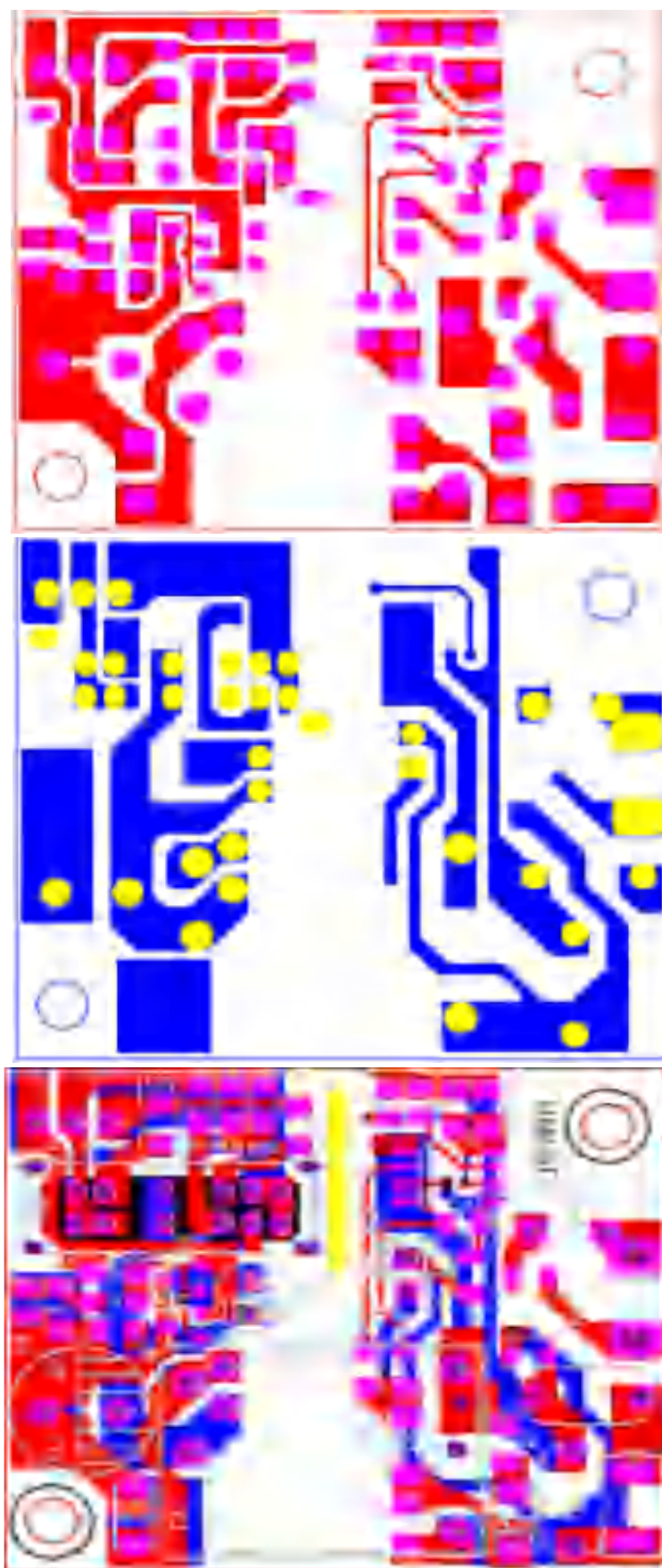
7.0 Illustrations

Illustration 108 - Circuit diagram for LED Driver model TR-071



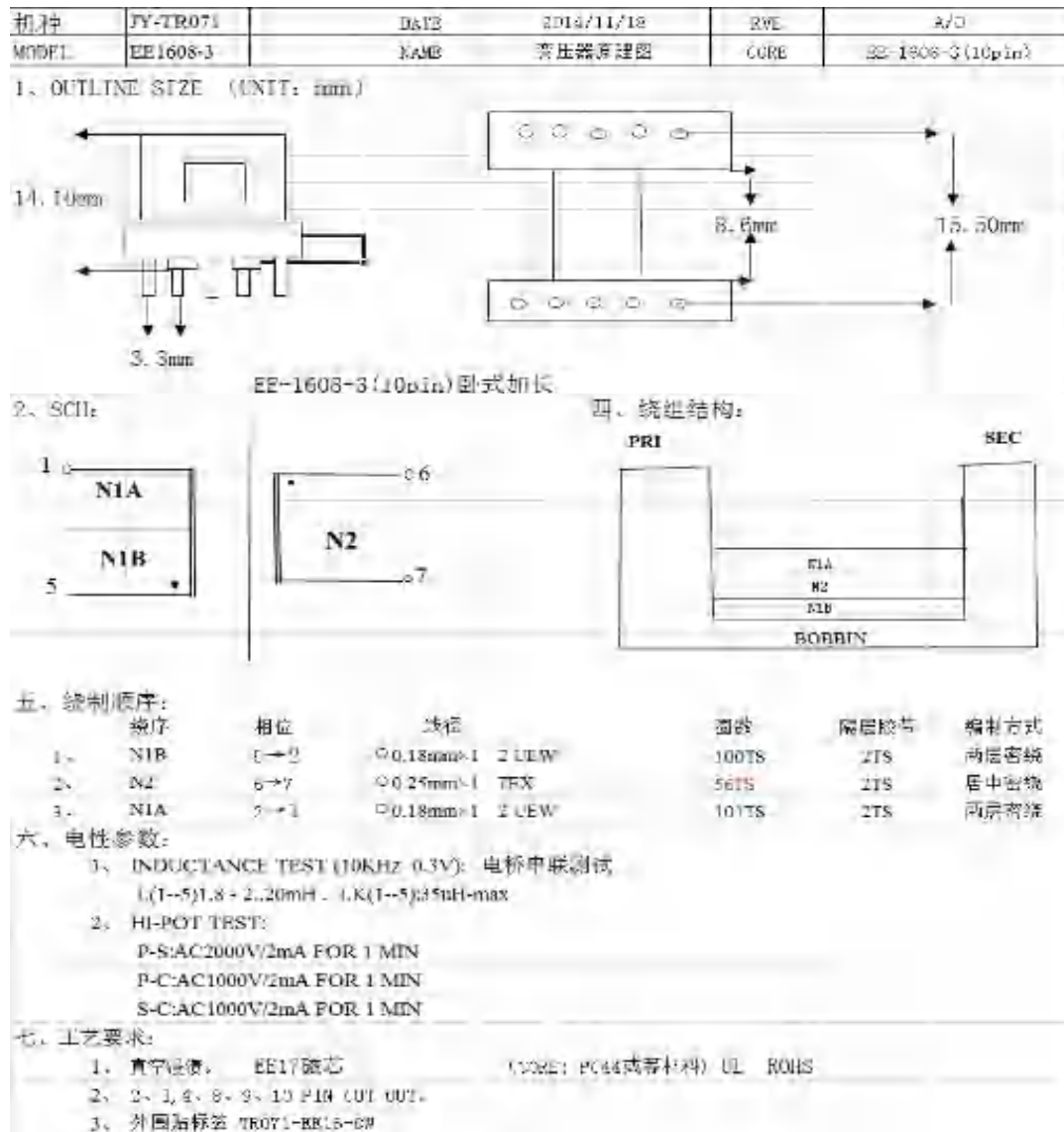
**7.0 Illustrations**

**Illustration 109** - PCB Layout diagram for LED Driver model TR-071



**7.0 Illustrations**

**Illustration 110 - Transformer T1 Specification for LED Driver model TR-071**



<b>8.0 Test Summary</b>			
Evaluation Period	25-Aug-2018 to 18-Oct-2018		Project No. HK18070260
Sample Rec. Date	24-Aug-2018	Condition	Prototype
			Sample ID. RSZ180712552-S01-S30
Test Location	Bay Area Compliance Lab Corp (Address: 6/F, The 3rd Phase of Wan Li Industrial Bldg, Shihua Road, Futian Free Trade Zone, Shenzhen, China)		
Test Procedure	Testing Lab		
Determination of the result includes consideration of measurement uncertainty from the test equipment and methods. The product was tested as indicated below with results in conformance to the relevant test criteria.			
The following tests were performed:			
			UL 1598:2018 Ed.4 & CSA C22.2#250.0:20 18 Ed.4
Test Description			Clause
Normal Temperature Test - Type IC recessed luminaires (intended for thermal insulation contact)			15.7
Barrier Strength			17.1
Mold stress relief			17.4
Conduit knockout and twistout			17.13
Loading			17.15
Snap-in or tab-mounted parts pull test without conduit opening			17.16
Suspended-ceiling luminaires – security of clips			17.18
Strain relief			17.21
Junction box rigidity			17.31
Polymeric impact			17.41
Dielectric voltage-withstand			18.1
Bonding circuit impedance			18.2
Articulate probe			18.4
			UL 8750:2015 Ed.2+R:05Feb2 018
			CSA C22.2#250.13:2 017 Ed.3
Test Description			Clause
Input Test			8.2
Temperature test			8.3
Dielectric Voltage-withstand			8.6
Component failure test			8.7.2
Output loading test			8.7.3
Leakage current measurement test			8.9
Humidity exposure			8.14.1
Determination of low-voltage, limited-energy circuit status			8.16
			9.2
			9.3
			9.4
			9.5.2
			9.5.3
			9.7
			9.12.1
			A.6-A.9

8.0 Test Summary			
Evaluation Period	25-Oct-2018 to 14-May-2019		Project No. HK19010772
Sample Rec. Date	24-Oct-2018	Condition Prototype	Sample ID. RSZ180712552-S01-S30
Test Location	Bay Area Compliance Lab Corp (Address: 6/F, The 3rd Phase of Wan Li Industrial Bldg, Shihua Road, Futian Free Trade Zone, Shenzhen, China)		
Test Procedure	Testing Lab		
Determination of the result includes consideration of measurement uncertainty from the test equipment and methods. The product was tested as indicated below with results in conformance to the relevant test criteria.			
Due to the previous testing performed under Intertek Report 18070260HKG-001, only the following testing was performed: (Added model JXL-COB03-T07W-UDD-, JXL-COB03-T10W-UDD-, JXL-TD04-A10W-UDD-, JXL-TD06-A12W-UDD-, JXL-COB04-T10W-UDD-, JXL-COF04-T10W-UDD-, JXL-TZ06-T15W-UDD-, JXL-CM06-T15W-UDD-, JXL-TA08-T18W-UDD-, JXL-TF08-T18W-UDD-, JXL-TE04-T12W-UDD-, JXL-TE06-T20W-UDD-, JXL-AF04-T10W-UDD-, JXL-AF06-T15W-UDD-, JXL-ZF03-T07W-UDD-xx, JXL-ZF04-T12W-UDD-xx, JXL-CA08-T25W-UDD-, JXL-CF08-T25W-UDD-, JXL-COB04-E15W-UDD-, JXL-TE06-T25W-CCT-, JXL-TE08-T25W-CCT-, JXL-COB06-F25/18/15W-UDD-, JXL-COB08-F25/18/15W-UDD-, JXL-TE06-E25/18/15W-UDD-, JXL-TE08-E25/18/15W-UDD-, JXL-COB08-F36W-UDD- or JXL-TE08-E36W-UDD-; followed by 27 to 65.)			
			UL 1598:2018 Ed.4 & CSA C22.2#250.0:2018 Ed.4
Test Description			Clause
Normal Temperature Test - Type IC recessed luminaires (intended for thermal insulation contact)			15.7
Barrier Strength			17.1
Conduit knockout and twistout			17.13
Loading			17.15
Snap-in or tab-mounted parts pull test without conduit opening			17.16
Suspended-ceiling luminaires – security of clips			17.18
Junction box rigidity			17.31
Dielectric voltage-withstand			18.1
Bonding circuit impedance			18.2
Articulate probe			18.4
			UL 8750:2015 Ed.2+R:22Aug2018
			CSA C22.2#250.13:2017 Ed.3
Test Description	Clause	Clause	
Input Test	8.2	9.2	
Temperature test	8.3	9.3	
Dielectric Voltage-withstand	8.6	9.4	
Component failure test	8.7.2	9.5.2	
Output loading test	8.7.3	9.5.3	
Leakage current measurement test	8.9	9.7	
Humidity exposure	8.14.1	9.12.1	
Determination of low-voltage, limited-energy circuit status	8.16	A.6-A.9	


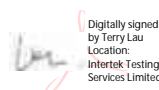
<b>8.0 Test Summary</b>			
Evaluation Period	25-Oct-2019 to 15-Apr-2020		Project No. HK19091444
Sample Rec. Date	20-Oct-2019	Condition	Prototype
			Sample ID. S1 to S88
Test Location	Intertek Testing Services HK Ltd. Guangdong Meide Testing Technology Co., Ltd. (Address:1st floor, B Area, Jinbaisheng Industrial Park, Headquarters 2 Road, Songshan Lake Hi-tech Industrial Development Zone, Dongguan City, Guangdong Pr., China.)		
Test Procedure	Testing at Manufacturers Premises (TMP) - Level 1		
Determination of the result includes consideration of measurement uncertainty from the test equipment and methods. The product was tested as indicated below with results in conformance to the relevant test criteria.			
The following tests were performed:			
			UL 1598:2018 Ed.4 & CSA C22.2#250.0:20 08 Ed.3 +G1;G2]
Test Description			Clause
Normal Temperature Test - Type IC recessed luminaires (intended for thermal insulation contact)			15.7
Barrier Strength			17.1
Conduit knockout and twistout			17.13
Loading			17.15
Snap-in or tab-mounted parts pull test without conduit opening			17.16
Suspended-ceiling luminaires – security of clips			17.18
Junction box rigidity			17.31
Dielectric voltage-withstand			18.1
Bonding circuit impedance			18.2
Articulate probe			18.4
			UL 8750:2015 Ed.2+R:22Aug2 018
			CSA C22.2#250.13:2 017 Ed.3
Test Description	Clause	Clause	
Input Test	8.2	9.2	
Temperature test	8.3	9.3	
Dielectric Voltage-withstand	8.6	9.4	
Component failure test	8.7.2	9.5.2	
Output loading test	8.7.3	9.5.3	
Leakage current measurement test	8.9	9.7	
Humidity exposure	8.14.1	9.12.1	
Determination of low-voltage, limited-energy circuit status	8.16	A.6-A.9	

8.0 Test Summary			
Evaluation Period	3-Nov-2021 to 17-Jan-2022		Project No. HK21110001, HK21091004
Sample Rec. Date	20-Oct-2021	Condition	Prototype
Sample ID.	S1 to S40, S122052		
Test Location	Bay Area Compliance Lab Corp (Address: 6/F, The 3rd Phase of Wan Li Industrial Bldg, Shihua Road, Futian Free Trade Zone, Shenzhen, China) Intertek Testing Services HK Ltd. (Address: Intertek, 2/F Garment Centre, 576 Castle Peak Road, Kowloon, Hong Kong SAR, China)		
Test Procedure	Testing Lab		
Determination of the result includes consideration of measurement uncertainty from the test equipment and methods. The product was tested as indicated below with results in conformance to the relevant test criteria.			
The following tests were performed:			
Test Description			UL 1598:2021 Ed.5+R:18Jun2021 & CSA C22.2#250.0:2021 Ed.5+U1
Normal Temperature Test - Type IC and LED Type Non-IC inherently protected recessed luminaires			Clause 15.8
Mold stress relief			17.4
Conduit knockout and twistout			17.13
Loading			17.15
Snap-in or tab-mounted parts pull test without conduit opening			17.16
Suspended-ceiling luminaires – security of clips			17.18
Junction box rigidity			17.31
Metal strength tests for reduced spacings			17.42
Dielectric voltage-withstand			18.1
Bonding circuit impedance			18.2
Articulate probe			18.4
Test Description	UL 8750:2015 Ed.2+R:23Sep2021	CSA C22.2#250.13:2020 Ed.4+U1	
Limited Short Circuit Test for fusible resistor	Clause 7.10.7	Clause 8.10.6	
Overload Test for fusible resistor	7.10.7	8.10.6	
Input Test	8.2	9.2	
Temperature test	8.3	9.3	
Dielectric Voltage-withstand	8.6	9.4	
Component failure test	8.7.2	9.5.2	
Leakage current measurement test	8.9	9.7	
Humidity exposure	8.14.1	9.12.1	
Determination of low-voltage, limited-energy circuit status	8.16	A.6-A.9	

<b>8.0 Test Summary</b>			
Evaluation Period	04-Dec-2021 to 24-Mar-2022		Project No. HK22020196
Sample Rec. Date	20-Oct-2021	Condition Prototype	Sample ID. S031427
Test Location	Bay Area Compliance Lab Corp (Address: 6/F, The 3rd Phase of Wan Li Industrial Bldg, Shihua Road, Futian Free Trade Zone, Shenzhen, China) Intertek Testing Services HK Ltd. (Address: Intertek, 2/F Garment Centre, 576 Castle Peak Road, Kowloon, Hong Kong SAR, China)		
Test Procedure	Testing Lab		
Determination of the result includes consideration of measurement uncertainty from the test equipment and methods. The product was tested as indicated below with results in conformance to the relevant test criteria.			
The following tests were performed:			
			UL 1598:2021 Ed.5+R:18Jun2021 & CSA C22.2#250.0:2021 Ed.5+U1
Test Description			Clause
Normal Temperature Test - Type IC and LED Type Non-IC inherently protected recessed luminaires			15.8
Barrier Strength			17.1
Mold stress relief			17.4
Conduit knockout and twistout			17.13
Loading			17.15
Snap-in or tab-mounted parts pull test without conduit opening			17.16
Suspended-ceiling luminaires – security of clips			17.18
Junction box rigidity			17.31
Metal strength tests for reduced spacings			17.42
Dielectric voltage-withstand			18.1
Bonding circuit impedance			18.2
Articulate probe			18.4
			UL 8750:2015 Ed.2+R:23Sep2021 CSA C22.2#250.13:2020 Ed.4+U1
Test Description	Clause	Clause	
Input Test	8.2	9.2	
Temperature test	8.3	9.3	
Dielectric Voltage-withstand	8.6	9.4	
Component failure test	8.7.2	9.5.2	
Output loading test	8.7.3	9.5.3	
Leakage current measurement test	8.9	9.7	
Humidity exposure	8.14.1	9.12.1	
Determination of low-voltage, limited-energy circuit status	8.16	A.6-A.9	

<b>8.0 Test Summary</b>			
Evaluation Period	15-Sep-2022 to 24-Oct-2022		Project No. HK22090371
Sample Rec. Date	15-Sep-2022	Condition Prototype	Sample ID. SZ2220914-41644E-S01-S15
Test Location	Bay Area Compliance Lab Corp (Address: 6/F, The 3rd Phase of Wan Li Industrial Bldg, Shihua Road, Futian Free Trade Zone, Shenzhen, China)		
Test Procedure	Testing at Manufacturers Premises (TMP) - Level 1		
Determination of the result includes consideration of measurement uncertainty from the test equipment and methods. The product was tested as indicated below with results in conformance to the relevant test criteria.			
The following tests were performed:			
			UL 1598:2021 Ed.5+R:18Jun2021 & CSA C22.2#250.0:2021 Ed.5+U1
Test Description			Clause
Normal Temperature Test - Type IC and LED Type Non-IC inherently protected recessed luminaires			15.8
Mold stress relief			17.4
Conduit knockout and twistout			17.13
Junction box rigidity			17.31
Metal strength tests for reduced spacings			17.42
Dielectric voltage-withstand			18.1
Bonding circuit impedance			18.2
Articulate probe			18.4
			UL 8750:2015 Ed.2+R:23Sep2021 CSA C22.2#250.13:2020 Ed.4+U1
Test Description	Clause	Clause	
Input Test	8.2	9.2	
Temperature test	8.3	9.3	
Dielectric Voltage-withstand	8.6	9.4	
Component failure test	8.7.2	9.5.2	
Output loading test	8.7.3	9.5.3	
Leakage current measurement test	8.9	9.7	
Humidity exposure	8.14.1	9.12.1	
Determination of low-voltage, limited-energy circuit status	8.16	A.6-A.9	

8.0 Test Summary			
Evaluation Period	24-Nov-2022 to 9-Feb-2022		Project No. HK22120435
Sample Rec. Date	23-Nov-2022	Condition	Prototype
			Sample ID. SZ2221122-56086E-S01-S25, S010414, S020609, S020908
Test Location	Intertek Testing Services HK Ltd. (Address: Intertek, 2/F Garment Centre, 576 Castle Peak Road, Kowloon, Hong Kong SAR, China), Bay Area Compliance Lab Corp (Address: 6/F, The 3rd Phase of Wan Li Industrial Bldg, Shihua Road, Futian Free Trade Zone, Shenzhen, China)		
Test Procedure	Testing Lab		
Determination of the result includes consideration of measurement uncertainty from the test equipment and methods. The product was tested as indicated below with results in conformance to the relevant test criteria.			
The following tests were performed:			
Test Description			UL 1598:2021 Ed.5+R:18Jun2021 & CSA C22.2#250.0:2021 Ed.5+U1
			Clause
Normal Temperature Test - Type IC and LED Type Non-IC inherently protected recessed			15.8
Mold stress relief			17.4
Conduit knockout and twistout			17.13
Suspended-ceiling luminaires – security of clips			17.18
Junction box rigidity			17.31
Metal strength tests for reduced spacings			17.42
Dielectric voltage-withstand			18.1
Bonding circuit impedance			18.2
Articulate probe			18.4
Test Description	UL 8750:2015 Ed.2+R:23Sep2021	CSA C22.2#250.13:2020 Ed.4+U1	
	Clause	Clause	
Input Test	8.2	9.2	
Temperature test	8.3	9.3	
Dielectric Voltage-withstand	8.6	9.4	
Component failure test	8.7.2	9.5.2	
Output loading test	8.7.3	9.5.3	
Leakage current measurement test	8.9	9.7	
Humidity exposure	8.14.1	9.12.1	
Determination of low-voltage, limited-energy circuit status	8.16	A.6-A.9	
Limited Short Circuit Test	7.10.7	8.10.6	
Overload Test	7.10.7	8.10.6	

8.1 Signatures			
A representative sample of the product covered by this report has been evaluated and found to comply with the applicable requirements of the standards indicated in Section 1.0.			
Completed by:	Mike Wong	Reviewed by:	Terry Lau
Title:	Lead Engineer	Title:	Supervisor
Signature:	 Digitally signed by Mike Wong Location: Intertek Testing Services Limited	Signature:	 Digitally signed by Terry Lau Location: Intertek Testing Services Limited

**9.0 Correlation Page For Multiple Listings**

The following products, which are identical to those identified in this report except for model number and Listee name, are authorized to bear the ETL label under provisions of the Intertek Multiple Listing Program.

BASIC LISTEE	Shenzhen goldsuno opto-electronic technology Co. Ltd.
Address	4F & 5F, Building B, Nuofeng Technology Park, Yuzhang 5Rd, Da Shui Tian, LONGHUA DISTRICT, Shenzhen
Country	China
Product	LED recessed luminaire

MULTIPLE LISTEE 1	Allstar Lighting Supplies Inc.
Address	33 Randolph Ave, Avenel NJ07001
Country	USA
Brand Name	LUXRITE

ASSOCIATED MANUFACTURER	Shenzhen goldsuno opto-electronic technology Co. Ltd.
Address	4F & 5F, Building B, Nuofeng Technology Park, Yuzhang 5Rd, Da Shui Tian, LONGHUA DISTRICT, Shenzhen
Country	China

MULTIPLE LISTEE 1 MODELS	BASIC LISTEE MODELS
LR23734	JXL-CA04-T10W-CCT
LR23736	JXL-CA06-T12W-CCT
LR23735	JXL-CF04-T10W-CCT
LR23737	JXL-CF06-T12W-CCT
LR23265	JXL-COB04-R15W-CCT
LR23267	JXL-COB04-S15W-CCT
LR32090	JXL-TXH05-T10W-UDN may be followed by 27 to 65.
LR32091	JXL-TXH05-T10W-UDN may be followed by 27 to 65.
LR32092	JXL-TXH05-T10W-UDN may be followed by 27 to 65.
LR32093	JXL-TXH05-T10W-UDN may be followed by 27 to 65.
LR32095	JXL-TXH10-T18W-UDN may be followed by 27 to 65.
LR32096	JXL-TXH10-T18W-UDN may be followed by 27 to 65.
LR32097	JXL-TXH10-T18W-UDN may be followed by 27 to 65.
LR32098	JXL-TXH10-T18W-UDN may be followed by 27 to 65.

MULTIPLE LISTEE 2	Bazz Inc.
Address	6000 Boul,Thimens Saint-Laurent, QC, H4S 1S5
Country	Canada
Brand Name	Bazz

ASSOCIATED MANUFACTURER	Shenzhen goldsuno opto-electronic technology Co. Ltd.
Address	4F & 5F, Building B, Nuofeng Technology Park, Yuzhang 5Rd, Da Shui Tian, LONGHUA DISTRICT, Shenzhen
Country	China

MULTIPLE LISTEE 2 MODELS	BASIC LISTEE MODELS
DISK2W	JXL-COB02-R08W-UDN may be followed by 27 to 65.
DISK4W	JXL-COB04-R12W-UDN may be followed by 27 to 65.
DISKCB5W	JXL-TXH05-T10W-UDN may be followed by 27 to 65.
DISKCB10W	JXL-TXH10-T18W-UDN may be followed by 27 to 65.

<b>9.0 Correlation Page For Multiple Listings</b>	
<b>MULTIPLE LISTEE 3</b>	Lighting Spot 26 LLC
Address	2021 E. 48th Street, Vernon, CA 90058
Country	USA
Brand Name	Lighting Spot26
<b>ASSOCIATED MANUFACTURER</b>	Shenzhen goldsuno opto-electronic technology Co. Ltd.
Address	4F & 5F, Building B, Nuofeng Technology Park, Yuzhang 5Rd, Da Shui Tian, LONGHUA DISTRICT, Shenzhen
Country	China
MULTIPLE LISTEE 3 MODELS	BASIC LISTEE MODELS
LS2-CS-2"R/S-3CCT,	JXL-COB02-R08W-CCT- followed by S or SM; followed by W, WH or MW.
LS2-CS-2"R/BF-3CCT,	JXL-COB02-R08W-CCT- followed by B or BF; followed by W, WH or MW.
LS2-CS-2"R/S-3CCT-BL,	JXL-COB02-R08W-CCT- followed by S or SM; followed by B, BL, BC or BK.
LS2-CS-2"R/BF-3CCT-BL,	JXL-COB02-R08W-CCT- followed by B or BF; followed by B, BL, BC or BK.
LS2-CS-2"SQ/S-3CCT,	JXL-COB02-S08W-CCT- followed by S or SM; followed by W, WH or MW.
LS2-CS-2"SQ/BF-3CCT,	JXL-COB02-S08W-CCT- followed by B or BF; followed by W, WH or MW.
LS2-CS-2"SQ/S-3CCT-BL,	JXL-COB02-S08W-CCT- followed by S or SM; followed by B, BL, BC or BK.
LS2-CS-2"SQ/BF-3CCT-BL,	JXL-COB02-S08W-CCT- followed by B or BF; followed by B, BL, BC or BK.
LS2-CS-4"R/S-3CCT,	JXL-COB04-R15W-CCT- followed by S or SM; followed by W, WH or MW.
LS2-CS-4"R/BF-3CCT,	JXL-COB04-R15W-CCT- followed by B or BF; followed by W, WH or MW.
LS2-CS-4"R/S-3CCT-BL,	JXL-COB04-R15W-CCT- followed by S or SM; followed by B, BL, BC or BK.
LS2-CS-4"R/BF-3CCT-BL,	JXL-COB04-R15W-CCT- followed by B or BF; followed by B, BL, BC or BK.
LS2-CS-4"SQ/S-3CCT,	JXL-COB04-S15W-CCT- followed by S or SM; followed by W, WH or MW.
LS2-CS-4"SQ/BF-3CCT,	JXL-COB04-S15W-CCT- followed by B or BF; followed by W, WH or MW.
LS2-CS-4"SQ/S-3CCT-BL,	JXL-COB04-S15W-CCT- followed by S or SM; followed by B, BL, BC or BK.
LS2-CS-4"SQ/BF-3CCT-BL,	JXL-COB04-S15W-CCT- followed by B or BF; followed by B, BL ,BC or BK.
LS2-CS-3"G-3K,	JXL-ZF03-T07W-UDD- followed by 3, 30 or 30K; followed by W, WH or MW.
LS2-CS-3"G-4K,	JXL-ZF03-T07W-UDD- followed by 4, 40 or 40K; followed by W, WH or MW.
LS2-CS-3"G-5K,	JXL-ZF03-T07W-UDD- followed by 5, 50 or 50K; followed by W, WH or MW.
LS2-CS-3"G-3K-BL,	JXL-ZF03-T07W-UDD- followed by 3, 30 or 30K; followed by B, BL ,BC or BK.
LS2-CS-3"G-4K-BL,	JXL-ZF03-T07W-UDD- followed by 4, 40 or 40K; followed by B, BL ,BC or BK.
LS2-CS-3"G-5K-BL	JXL-ZF03-T07W-UDD- followed by 5, 50 or 50K; followed by B, BL ,BC or BK.

<b>9.0 Correlation Page For Multiple Listings</b>	
<b>MULTIPLE LISTEE 4</b>	Onelux Lighting
Address	2883 Portland Drive Oakville, ON L6H 5S4
Country	Canada
Brand Name	Onelux
<b>ASSOCIATED MANUFACTURER</b>	Shenzhen goldsuno opto-electronic technology Co. Ltd.
Address	4F & 5F, Building B, Nuofeng Technology Park, Yuzhang 5Rd, Da Shui Tian, LONGHUA DISTRICT, Shenzhen
Country	China
MULTIPLE LISTEE 4 MODELS	BASIC LISTEE MODELS
VEG-5- followed by 30, 40 or 50; followed by -UNV-90-; followed by W, WH, MW, B, BL, BC or BK.	JXL-TXH05-T10W-UDN- followed by 30, 40 or 50; followed by -; followed by W, WH, MW, B, BL, BC or BK.
VEG-W5- followed by 30, 40 or 50; followed by -UNV-90-; followed by W, WH, MW, B, BL, BC or BK.	JXL-TX05-T10W-UDN- followed by 30, 40 or 50; followed by -; followed by W, WH, MW, B, BL, BC or BK.
VEG-10- followed by 30, 40 or 50; followed by -UNV-90-; followed by W, WH, MW, B, BL, BC or BK.	JXL-TXH10-T18W-UDN- followed by 30, 40 or 50; followed by -; followed by W, WH, MW, B, BL, BC or BK.
VEG-W10- followed by 30, 40 or 50; followed by -UNV-90-; followed by W, WH, MW, B, BL, BC or BK.	JXL-TX10-T18W-UDN- followed by 30, 40 or 50; followed by -; followed by W, WH, MW, B, BL, BC or BK.
DAL2-RD-OCC-M-120-90- followed by W, WH, MW, B, BL, BC or BK.	JXL-COB02-R08W-CCT-S followed by W, WH, MW, B, BL, BC or BK.
DAL2-SQ-OCC-M-120-90- followed by W, WH, MW, B, BL, BC or BK.	JXL-COB02-S08W-CCT-S followed by W, WH, MW, B, BL, BC or BK.
DAL4-RD-OCC-M-120-90- followed by W, WH, MW, B, BL, BC or BK.	JXL-COB04-R12W-CCT-S followed by W, WH, MW, B, BL, BC or BK.
DAL4-SQ-OCC-M-120-90- followed by W, WH, MW, B, BL, BC or BK.	JXL-COB04-S12W-CCT-S followed by W, WH, MW, B, BL, BC or BK.
<b>MULTIPLE LISTEE 5</b>	Super Bright LEDs, Inc.
Address	4400 Earth City Expressway, Earth City, MO, 63045
Country	USA
Brand Name	superbrightleds.com
<b>ASSOCIATED MANUFACTURER</b>	Shenzhen goldsuno opto-electronic technology Co. Ltd.
Address	4F & 5F, Building B, Nuofeng Technology Park, Yuzhang 5Rd, Da Shui Tian, LONGHUA DISTRICT, Shenzhen
Country	China
MULTIPLE LISTEE 5 MODELS	BASIC LISTEE MODELS
DLS4D-RGBCCT-10W	JXL-TZ04-T10W-RGBCW
DLS6D-RGBCCT-12W	JXL-TZ06-T12W-RGBCW

## 10.0 General Information

The Applicant and Manufacturer have agreed to produce, test and label ETL Listed products in accordance with the requirements of this Report. The Manufacturer has also agreed to notify Intertek and to request authorization prior to using alternate parts, components or materials.

### COMPONENTS

Components used shall be those itemized in this Intertek report covering the product, including any amendments and/or revisions.

### LISTING MARK

The ETL Listing mark applied to the products shall either be separable in form, such as labels purchased from Intertek, or on a product nameplate or other media only as specifically authorized by Intertek. Use of the mark is subject to the control of Intertek.

The mark must include the following four items:

- 1) applicable country identifiers "US" and/or "C" or "US", "C" and "EU"
- 2) the word "Listed" or "Classified" or "Recognized Component" (whichever is appropriate)
- 3) a control number issued by Intertek
- 4) a product descriptor that identifies the standards used for certification. Example:

**For US standards**, the words, "Conforms to" shall appear with the standard number along with the word, "Standard" or "Std." Example: "Conforms to ANSI/UL Std. XX."

**For Canadian standards**, the words "Certified to CAN/CSA Standard CXX No. XX." shall be used, or abbreviated, "Cert. to CAN/CSA Std. CXX No. XX."

Can be used together when both standards are used.

**If all standards on the ATM have the same standard title**, the shared title or its abbreviation may be used in place of the examples above. Example: "Medical Electrical Equipment" or "MEE"; "Information Technology Equipment" or "ITE"; "Audio/Video Information And Communication Technology Equipment" or "A/V ICTE".

### **Note: A facsimile must be submitted to Intertek, Attn: Follow-up Services for approval prior to use.**

The facsimile need not have a control number. A control number will be issued **after signed Certification Agreements** have been received by the Follow-up Services office, approval of the facsimile of your proposed Listing Mark, satisfactory completion of the Listing Report, and scheduling of a factory assessment in your facility.

### MANUFACTURING AND PRODUCTION TESTS

Manufacturing and Production Tests shall be performed as required in this Report.

### FOLLOW-UP SERVICE

Periodic unannounced audits of the manufacturing facility (and any locations authorized to apply the mark) shall be scheduled by Intertek. An audit report shall be issued after each visit. Special attention will be given to the following:

1. Conformance of the manufactured product to the descriptions in this Report.
2. Conformance of the use of the ETL mark with the requirements of this Report and the Certification Agreement.
3. Manufacturing changes.
4. Performance of specified Manufacturing and Production Tests.

In the event that the Intertek representative identifies non-conformance(s) to any provision of this Report, the Applicant shall take one or more of the following actions:

1. Correct the non-conformance.
2. Remove the ETL Mark from non-conforming product.
3. Contact the issuing product safety evaluation center for instructions.

### 10.1 Evaluation of Unlisted Components

Because Unlisted Components are uncontrolled, and they do not fall under a third party follow up program, Intertek may require these components to be tested and/or evaluated at least once annually, more often for certain components, as part of the independent certification process. The Unlisted Components in Section 5.0 require testing and/or evaluation as indicated.

**The Applicant will be notified, in writing, via the applicable contact methods, as defined in Section 1.0, when these components must be selected and sent to Component Evaluation Center (CEC) for re-evaluation.**

**Due to particular testing requirements, some components may be requested to be shipped to specific labs. Thus, specific shipment destination(s) for each sample will be provided in the written notification.**

Managing CEC Location:

Intertek Testing Services Hong Kong Limited

ETL Component Evaluation Center

Unit H, 3/F., Garment Centre, 576 Castle Peak Road

Kowloon, Hong Kong

Attn: Sample Room

Sample Disposition: Due to the destructive nature of the testing, all samples will be discarded at the conclusion of testing unless, the manufacturer specifically requests the return of the samples. The request for return must accompany the initial component shipment.

**11.0 Manufacturing and Production Tests**

The manufacturer agrees to conduct the following Manufacturing and Production Tests as specified:

**Required Tests**

Dielectric Voltage Withstand Test or Insulation Resistance Test,  
 Grounding Continuity Test,  
 Accessible edges

**11.1 Dielectric Voltage Withstand Test**

Method

One hundred percent of production of the products covered by this Report shall be subjected to a routine production line dielectric withstand test.

The test shall be conducted on products, which are fully assembled. Prior to applying the test potential, all switches, contactors, relays, etc., should be closed so that all primary circuits are energized by the test potential. If all primary circuits cannot be tested at one time, then separate applications of the test potential shall be made.

The test voltage specified below shall be applied between primary circuits and accessible dead-metal parts. The test voltage may be gradually increased to the specified value but must be maintained at the specified value for one second.

Test Equipment

The test equipment shall incorporate a transformer with an essentially sinusoidal output, a means to indicate the applied test potential, and an audible and/or visual indicator of dielectric breakdown.

The test equipment shall incorporate a voltmeter in the output circuit to indicate directly the applied test potential if the rated output of the test equipment is less than 500VA.

If the rated output of the test equipment is 500VA or more, the applied test potential may be indicated by either:

- 1 - a voltmeter in the primary circuit;
- 2 - a selector switch marked to indicate the test potential; or
- 3 - a marking in a readily visible location to indicate the test potential for test equipment having a single test potential output.

In cases 2 and 3, the test equipment shall include a lamp or other visual means to indicate that the test potential is present at the test equipment output. All test equipment shall be maintained in current calibration.

Alternative Method

A 500 V dc insulation resistance test on 100% of production can be considered representative of the 100% dielectric voltage-withstand test and may be used as an alternative method.

Test Equipment for Alternative Method

The insulation resistance measurement of Clause I.1.7 should be made using a dc insulation tester capable of delivering the appropriate open circuit voltage (i.e., 500 V dc), or other suitable equipment.

The test voltage should be applied for a minimum duration of 1 s. The measured resistance should not be less than 2 MΩ. For safety reasons, the test should be performed with the luminaire disconnected from the power supply.

All test equipment shall be maintained in current calibration.

Test Record

Test records shall be retained for a period of at least six months, and include test quantity, test dates, catalog or model numbers, test results, and disposition of any non-complying products.

**Products Requiring Dielectric Voltage Withstand Test:**

<u>Product</u>	<u>Test Voltage</u>	<u>Test Time</u>
All products covered by this report. Dielectric Withstand Voltage Test	1200V	1 second
One sample from each shipment of Section 4.0 item 139, 143, 176, 186, 186a, 215, 250, 256, 260: Between primary circuit and secondary circuit	1240V (40-70Hz) or 1748VDC	1 minute

<b>11.1a Insulation Resistance Test</b>
<p><u>Method</u>                      A 500 V dc insulation resistance test on 100% of production can be considered representative of the 100% dielectric voltage-withstand test and may be used as an alternative method.</p> <p><u>Test Equipment</u>                      The insulation resistance measurement of Clause I.1.7 should be made using a dc insulation tester capable of delivering the appropriate open circuit voltage (i.e., 500 V dc), or other suitable equipment.                      The test voltage should be applied for a minimum duration of 1 s. The measured resistance should not be less than 2 MΩ. For safety reasons, the test should be performed with the luminaire disconnected from the power supply.</p> <p>All test equipment shall be maintained in current calibration.</p>

<b>11.2 Grounding Continuity Test</b>
<p><u>Method</u>                      All luminaires shall be subjected to test at least once per quarter per design. The test shall be performed on luminaires with non-current-carrying metal parts that may become energized and are accessible during user maintenance or snap-in lampholders with integral grounding means.</p> <p>An ac or dc power supply of approximately 12V providing a current of 30A through the bonding means being evaluated. Alternatively, it may be determined by an ohmmeter or similar indicating instrument. The measured or calculated resistance shall not exceed 0.10 ohm.</p> <p><u>Test Record</u>                      Test records shall be retained for a period of at least six months, and include test quantity, test dates, catalog or model numbers, test results, and disposition of any non-complying products.</p>

<b>Products Requiring Grounding Continuity Test:</b>	
<u>Product</u>	<u>Resistance</u>
All products covered by this Report.	Not exceed 0.1 ohm

<b>11.3 Accessible edges</b>	
<p><u>Method</u>                      An enclosure, frame, or similar device shall not have accessible edges that are sharp or pointed such that they constitute a risk of injury to persons during normal installation, maintenance, and use, unless:</p> <ul style="list-style-type: none"> <li>a) accessible edges are protected by guards or the use of handles to minimize access to sharp edges during installation or maintenance;</li> <li>b) an accessible edge or portion of an accessible edge shall be required to be sharp in order to perform a working function; or</li> <li>c) it is possible to avoid the hazard through proper procedures; then signs, labels, or the manufacturer's instructions shall describe the procedure to avoid the hazard during installation, maintenance, and use.</li> </ul> <p>Whenever referee measurements are necessary to determine that a part as mentioned above is not sufficiently sharp to constitute a risk of injury to persons, the method described in UL 1439, Tests for Sharpness of Edges on Equipment, shall apply.</p> <p>One sample of each luminaire style that contains an accessible edge that does not comply with (a), (b), or (c), shall be tested twice annually.</p> <p><u>Test Record</u>                      Test records shall be retained for a period of at least six months, and include test quantity, test dates, catalogue or model numbers, test results, and disposition of any non-complying products.</p>	
<b>Products Requiring Accessible edges:</b>	
All products covered by this Report.	



12.0 Revision Summary				
The following changes are in compliance with the declaration of Section 8.1:				
Date/ Proj # Site ID	Project Handler/ Reviewer	Section	Item	Description of Change
	Cont'd	6.0	9	Revised "ETL listed mark" to "Certification Mark as authorized in the Authorization to Mark".
		7.0	ill 23 - 49	Added illustrations for new models.
		8.0	--	Adding testing summary.
20-Apr-2020	Mike Wong		--	Added manufacturer 2: Smart Wisdom Enterprise Limited.
HK19091444 HKG	Terry Lau	1.0	--	Revised applicant and manufacturer 1 e-mail from "CZ@goldsuno.com" to "cz@goldsuno.com".
			--	Revised standard from "Luminaires [CSA C22.2#250.0:2018 Ed.4]" to "Luminaires (R2013) [CSA C22.2#250.0:2008 Ed.3 +G1;G2]".
			2.0	--
		--	Added ratings and model similarity for new models.	
		3.0	143-209	Added photos for new models.
		4.0	39,40	Added back components information due to typing error.
			84-122	Added components for new models
		5.0	97d,97e,98d,99d,100d,101d,103d,103e,104d,106d,106e	Added unlisted components for new models.
			29	Revised unlisted component number and information form "item 28, inductors 1 (LF2)" to "item 29, Transformer 1 (T1)" due to typing error.
			39	Revised unlisted component number and information form "item 37c, Insulated tape of SK" to "item 39, Transformer 2 (T1)" due to typing error.
		6.0	9	Added marking system requirement.
			10,11	Removed "both in French and English"
		7.0	50,51	Added model list for LED specification and LED driver.
			52-84a	Added PCB layout, circuit diagram, transformer construction, model difference for new models.
8.0	--	Added Test Summary.		
11.0	1	Updated test method for Dielectric Voltage Withstand Test.		

12.0 Revision Summary				
The following changes are in compliance with the declaration of Section 8.1:				
Date/ Proj # Site ID	Project Handler/ Reviewer	Section	Item	Description of Change
29-Sep-2020 HK20090953 HKG	Oscar Ho Eric Chau	9.0	ML1	Added Multiple Listee 1 - "Allstar Lighting Supplies Inc."
18-Jan-2021 HK21010625 HKG	Mike Wong Eric Chau	1.0	--	Updated standard from "Luminaires (R2013) [CSA C22.2#250.0:2008 Ed.3 +G1;G2]" to "Luminaires (R2013)>Valid without technical revision: 30Oct2021< [CSA C22.2#250.0:2008 Ed.3+G1;G2] "
		9.0	ML1	Revised format of Multiple Listee 1 - "Allstar Lighting Supplies Inc." Basic Listee models "JXL-TXH05-T10W-UDN- may be followed by 27 to 65.", "JXL-TXH10-T18W-UDN- may be followed by 27 to 65" to "JXL-TXH05-T10W-UDN may be followed by 27 to 65.", "JXL-TXH10-T18W-UDN may be followed by 27 to 65" as typo.
			ML2	Added Multiple Listee 2 - "Bazz Inc."
27-Jan-2022 HK21110001 HKG	Andy Tse	1.0	--	Updated standard from "Luminaires [UL 1598:2018 Ed.4], Luminaires (R2013) [CSA C22.2#250.0:2008 Ed.3+G1;G2] " to "Luminaires [UL 1598:2021 Ed.5+R:18Jun2021]" "Luminaires [CSA C22.2#250.0:2021 Ed.5+U1]"
			--	Removed Manufacturer 2 - "Smart Wisdom Enterprise Limited" (Control no.: 5016567).
	Terry Lau	2.0	--	Revised models from "JXL-COB03-T07W-UDD-, JXL-COB03-T10W-UDD-, JXL-TD04-A10W-UDD-, JXL-TD06-A12W-UDD-, JXL-COB04-T10W-UDD-, JXL-COF04-T10W-UDD-, JXL-TZ06-T15W-UDD-, JXL-CM06-T15W-UDD-, JXL-TA08-T18W-UDD-, JXL-TF08-T18W-UDD-, JXL-TE04-T12W-UDD-, JXL-TE06-T20W-UDD-, JXL-AF04-T10W-UDD-, JXL-AF06-T15W-UDD-, JXL-ZF03-T07W-UDD-xx, JXL-ZF04-T12W-UDD-xx, JXL-CA08-T25W-UDD-, JXL-CF08-T25W-UDD-, JXL-COB04-E15W-UDD-, JXL-TE06-T25W-CCT -, JXL-TE08-T25W-CCT -, JXL-COB06-F25/18/15W-UDD-, JXL-COB08-F25/18/15W-UDD-, JXL-TE06-E25/18/15W-UDD-, JXL-TE08-E25/18/15W-UDD-, JXL-COB08-F36W-UDD- or JXL-TE08-E36W-UDD-; followed by 27 to 65." to "JXL-COB03-T07W-UDD, JXL-COB03-T10W-UDD, JXL-TD04-A10W-UDD, JXL-TD06-A12W-UDD, JXL-COB04-T10W-UDD, JXL-COF04-T10W-UDD, JXL-TZ06-T15W-UDD, JXL-CM06-T15W-UDD, JXL-TA08-T18W-UDD, JXL-TF08-T18W-UDD, JXL-TE04-T12W-UDD, JXL-TE06-T20W-UDD, JXL-AF04-T10W-UDD, JXL-AF06-T15W-UDD, JXL-ZF03-T07W-UDD, JXL-ZF04-T12W-UDD, JXL-CA08-T25W-UDD, JXL-CF08-T25W-UDD, JXL-COB04-E15W-UDD, JXL-TE06-T25W-CCT , JXL-TE08-T25W-CCT , JXL-COB06-F25/18/15W-UDD, JXL-COB08-F25/18/15W-UDD, JXL-TE06-E25/18/15W-UDD, JXL-TE08-E25/18/15W-UDD, JXL-COB08-F36W-UDD or JXL-TE08-E36W-UDD; may be followed by -; may be followed by one to two numbers; may be followed by K; may be followed by W, WH, MW, B, BL, BC or BK."

12.0 Revision Summary				
The following changes are in compliance with the declaration of Section 8.1:				
Date/ Proj # Site ID	Project Handler/ Reviewer	Section	Item	Description of Change
	Cont'd			<p>Revised models from                      "JXL-COB02-R08W-UDN, JXL-COB02-S08W-UDN, JXL-COB04-R12W-UDN, JXL-COB04-S12W-UDN, JXL-COB04-S15W-UDN, JXL-COB04-R15W-UDN, JXL-SMD04-G10W-UDN, JXL-COB04-G10W-UDN, JXL-COB04-G10W-CCT, JXL-SMD04-G10W-CCT, JXL-TE04-T12W-UDN, JXL-TEH04-T12W-UDN, JXL-TE06-T20W-UDN, JXL-TE08-T25W-UDN, JXL-TE06-G12W-UDN, JXL-TE06-T12W-UDN, JXL-TE08-T18W-UDN, JXL-TX05-T10W-UDN, JXL-TX10-T18W-UDN, JXL-TXH10-T18W-UDN, JXL-TXH05-T10W-UDN, JXL-TZ04-T10W-UDN, JXL-TZ06-T12W-UDN, JXL-CA04-T10W-UDN, JXL-CA06-T12W-UDN, JXL-TZ04-R10W-CCT, JXL-TZ06-R12W-CCT, JXL-COB04-R12W-CCT, JXL-COB04-S12W-CCT, JXL-TXH03-T10W-CCT, JXL-TXH05-T18W-CCT, JXL-COB04-R15W-CCT, JXL-COB04-S15W-CCT, JXL-COB02-R08W-CCT, JXL-COB02-S08W-CCT, JXL-CA04-T10W-CCT, JXL-CA06-T12W-CCT, JXL-CM06-T12W-CCT, JXL-CM04-T10W-CCT, JXL-CF04-T10W-CCT or JXL-CF06-T12W-CCT; may be followed by 27 to 65." to                      "JXL-COB02-R08W-UDN, JXL-COB02-S08W-UDN, JXL-COB04-R12W-UDN, JXL-COB04-S12W-UDN, JXL-COB04-S15W-UDN, JXL-COB04-R15W-UDN, JXL-SMD04-G10W-UDN, JXL-COB04-G10W-UDN, JXL-COB04-G10W-CCT, JXL-SMD04-G10W-CCT, JXL-TE04-T12W-UDN, JXL-TEH04-T12W-UDN, JXL-TE06-T20W-UDN, JXL-TE08-T25W-UDN, JXL-TE06-G12W-UDN, JXL-TE06-T12W-UDN, JXL-TE08-T18W-UDN, JXL-TX05-T10W-UDN, JXL-TX10-T18W-UDN, JXL-TXH10-T18W-UDN, JXL-TZ04-T10W-UDN, JXL-TZ06-T12W-UDN, JXL-CA04-T10W-UDN, JXL-CA06-T12W-UDN, JXL-TZ04-R10W-CCT, JXL-TZ06-R12W-CCT, JXL-COB04-R12W-CCT, JXL-COB04-S12W-CCT, JXL-TXH03-T10W-CCT, JXL-TXH05-T18W-CCT, JXL-COB04-R15W-CCT, JXL-COB04-S15W-CCT, JXL-COB02-R08W-CCT, JXL-COB02-S08W-CCT, JXL-CA04-T10W-CCT, JXL-CA06-T12W-CCT, JXL-CM06-T12W-CCT, JXL-CM04-T10W-CCT, JXL-CF04-T10W-CCT or JXL-CF06-T12W-CCT; may be followed by -; may be followed by 27 to 65; may be followed by -; may be followed by S, SM, B or BF; may be followed by W, WH, MW, B, BL, BC, BK, WB, WHB, WBK, WBL or CM."</p> <p>Added models "JXL-TXH05-T10W-UDN may be followed by -; may be followed by 27 to 65; may be followed by -; may be followed by S, SM, B or BF; may be followed by W, WH, MW, B, BL, BC, BK, WB, WHB, WBK, WBL or CM; may be followed by -; may be followed by A."</p>
		2.0	--	

12.0 Revision Summary				
The following changes are in compliance with the declaration of Section 8.1:				
Date/ Proj # Site ID	Project Handler/ Reviewer	Section	Item	Description of Change
	Cont'd			Revised note "1. The number 27 to 65 (represents as xx) denotes the CCT of LEDs." to "1. The number 27 to 65 or one to two numbers (represents as xx) denotes the CCT of LEDs. 1a. Suffix S, SM, B or BF denotes the different trim finish, for example, S or SM for Smooth Design; B or BF for Baffle design. 1b. Suffix W, WH, MW, B, BL, BC, BK, WB, WHB, WBK, WBL or CM denotes finish color, for example, W or WH or MW for all white; B, BL, BC or BK for all black; WB, WHB, WBK or WBL for white with black, CM for Chrome." in Model Similarity Table.
		2.0	--	Revised note "7. LED driver model TR-031A,TR-031B with same schematic diagram and PCB layout, refer to Illustration 84a for the component difference table." to "7. LED driver model TR-031A, TR-031B with same schematic diagram, and different PCB layout, refer to Illustration 84b for the component difference table." in Model Similarity Table. Added note 8, 9 in Model Similarity Table. Added alternative LED driver model for models JXL-ZF03-T07W-UDD-xx, JXL-COB02-R08W-UDN-XX, JXL-COB02-S08W-UDN-XX, JXL-COB04-R12W-UDN-XX, JXL-COB04-S12W-UDN-XX in Model Similarity Table.
			--	Divided models JXL-TXH05-T10W-UDN-XX into JXL-TXH05-T10W-UDN-XX-A (Used LED driver: TR-023A) and JXL-TXH05-T10W-UDN-XX (Used LED driver: TR120B) in Model Similarity and Ratings Table.
			31	Updated callout no.
			95a, 96a, 97a, 146a-146r, 150a-150r	Added photos for alternative construction.
			145, 149	Added callout# 84a.
			150	Revised callout# 90 to 92 due to typo.
			169	Added callout# 15.
		3.0	169, 173, 177, 181, 185	Revised callout# from "84" to "84b, 84c", and from "85" to "85a" due to typo.
			170	Revised callout# from "84" to "84b, 84c".
			171-174, 191, 197-199, 200	Updated title.
			199	Added callout# 87, 88, 110.
			199a	Added photos for new construction.
			207, 208	Updated photos for new construction.
			207a	Added callout# 114.
			210-219a	Added photos for new LED drivers models TR120A and TR120B.
			220-221a	Added photos for Transformer (T1) construction of driver TR-019 and TR-031A.
		4.0	11	Added photo# 96a, 173.
			12	Combined component item 12 and 12a into item 12.
			14	Revised Mark(s) of conformity from "UR" to "UL".
			15	Added photo# 169, 173.



12.0 Revision Summary				
The following changes are in compliance with the declaration of Section 8.1:				
Date/ Proj # Site ID	Project Handler/ Reviewer	Section	Item	Description of Change
	Cont'd	4.0	44	Added photo# 97a.
			45	Added photo# 95a.
			48	Added photo# 96, 96a.
			80	Revised "(Item 80a-80c)" to "(Item 80a-80b)" in technical information due to typo.
			80b	Revised photo# from "149, 150" to "140, 141" due to typo.
			82	Added photo# 96a.
			84, 85, 86	Added photo# 146b, 146e, 146h, 146k, 146n, 146q, 150b, 150e, 150h, 150k, 150n, 150q.
			87	Added photo# 146b, 146e, 146h, 146k, 146n, 146q, 150b, 150e, 150h, 150k, 150n, 150q, 169, 170, 173, 177, 181, 185, 189, 193, 196a, 199.
			87a	Removed component: Output wire.
			88	Added photo# 146b, 146e, 146h, 146k, 146n, 146q, 150b, 150e, 150h, 150k, 150n, 150q, 199.
			89, 90, 92, 93	Added photo# 146c, 146f, 146i, 146l, 146o, 146r, 150c, 150f, 150i, 150l, 150o, 150r.
			99d	Added photo# 220, 220a.
			105, 106	Added include item 114 in technical information.
			106d	Added photo# 221, 221a.
				Revised "refer to Illustration 83 and 84." to "refer to Illustration 84a." in technical information.
			106h	Added "Refer 7.0 illustration No. 84c for detail construction." in technical information.
			106h2	Removed photo# 207.
			109, 111-113	Added photo# 199a.
			114	Added photo# 207, 207a, 209.
				Removed photo# 208.
			115	Added photo# 208a.
			116	Added photo# 209.
			123-143h	Added components for new LED drivers.
			5.0	29, 39
		29, 39, 71, 71a, 76, 81, 81a, 97d, 97e, 98d, 99d, 100d, 101d, 103d, 103e, 104d, 106d, 106e		Updated Component Standard used from "UL 8750:2015 Ed.2+R:22Aug2018 CAN/CSA C22.2#250.13:2017 Ed.3" to "UL 8750:2015 Ed.2+R:23Sep2021 CSA C22.2#250.13:2020 Ed.4+U1".
		71, 76		Revised Electrical Rating from "NA" to "650uH".
		71a		Revised Electrical Rating from "NA" to "1000uH".
		81, 81a		Revised Electrical Rating from "NA" to "400uH".
		81a		Revised "refer to illustration 44-45" to "refer to illustration 46-47" due to typo.
		97e		Revised "refer to illustration 54 to 55" to "refer to illustration 56 to 57" due to typo.
		98d, 99d		Divided into 2 unlisted component items: model TR-019 (photo# 202) for item 98d; model TR-012B (photo# 203, 220, 220a) for item 99d.

12.0 Revision Summary					
The following changes are in compliance with the declaration of Section 8.1:					
Date/ Proj # Site ID	Project Handler/ Reviewer	Section	Item	Description of Change	
HK21091004 HKG	Cont'd	5.0	100d, 101d, 103d, 103e, 106d, 106e	Revised all Test Voltage from "1240Vac" to "1554Vac".	
			103e	Revised "refer to illustration 78 to 80" to "refer to illustration 78, 80" due to typo.	
			106d, 106e	Divided into 2 unlisted component items: model TR031A (photo# 207, 221, 221a) for item 98d; model TR031B (photo# 207a) for item 99d.	
			133, 133a	Added new unlisted components for new LED drivers.	
		6.0	9	Revised "2. Applicant Name or Brand Name/Trademark (S16-L2)" to "2. Applicant Name or Brand Name (S16-L2)".	
				Revised "S24" to "S16".	
			10	Revised "S24" to "S16". Added new cautionary markings.	
		13	Added Transformer Features.		
		7.0	1	Updated Format Designation of Markings and Instructions.	
			2	Updated Markings sample.	
			51	Revised "5)TR031A" to "5)TR-031A".	
			81	Updated title.	
				Rotated the illustration 180°.	
			81a	Added Circuit diagram for LED Driver model TR-031A.	
			82	Updated title.	
			82a	Added PCB Layout diagram for LED Driver model TR-031A.	
			83, 84	Updated title.	
			84a	Revised illustration from Model difference between LED Driver TR-031A and TR-031B to Transformer T1 Specification for model TR-031A	
		84b, 84c	Added illustrations for LED Driver TR-031A and TR-031B.		
		85-91	Added illustrations for new LED Drivers.		
		8.0	--	Added Test Summary.	
		9.0	ML3	Added ML3 - "Lighting Spot 26 LLC".	
			ML4	Added ML4 - "Onelux Lighting".	
		11.0, 11.1a, 11.3	--	Added Insulation Resistance Test, Accessible edges.	
		11.1	--	Added Test Product - One sample from each shipment of Section 4.0 item 139, 143.	

12.0 Revision Summary				
The following changes are in compliance with the declaration of Section 8.1:				
Date/ Proj # Site ID	Project Handler/ Reviewer	Section	Item	Description of Change
28-Mar-2022  HK22020196 HKG	Mike Wong	2.0	--	Added new models: JXL-TZ04-T10W-5CCT, JXL-CM04-T10W-5CCT, JXL-TZ06-T12W-5CCT, JXL-CM06-T12W-5CCT, JXL-CA04-T10W-5CCT, JXL-CF04-T10W-5CCT, JXL-CA06-T12W-5CCT, JXL-CF06-T12W-5CCT, JXL-COB04-G12W-5CCT, JXL-TZ04-T10W-RGBCW, JXL-CA04-T10W-RGBCW, JXL-TZ06-T12W-RGBCW, JXL-CA06-T12W-RGBCW. JXL-TEH06-T18W-UDN may be followed by -; may be followed by 27 to 65.
			--	Added model similarity and ratings for new models.
	Terry Lau	3.0	222-292	Added photos for new models.
		4.0	6a,100	Added photo number for new model.
			144-205	Added components for new models.
		5.0	172,183,183a	Added unlisted components for new models.
		6.0	9	Added marking system requirement.
			13	Added Transformer production test requirements.
		7.0	92,93,95,95a,96	Added circuit diagram and PCB layout for new models.
			94,97,98	Added Transformer Features.
		8.0	--	Added Test Summary.
11.0	1	Added Transformer production test requirements.		
12-May-2022  HK22041039 HKG	Oscar Ho	1.0	Address	Revised applicant and manufacturer's "401 B Building, Shan Yuehua Technology Park, No.63 Xintang Village, Fucheng Street,Longhua District,Shenzhen,Guangdong" to "4F & 5F, Building B, Nuofeng Technology Park, Yuzhang 5Rd, Da Shui Tian, LONGHUA DISTRICT, Shenzhen".
			--	Revised BASIC LISTEE's address "401 B Building, Shan Yuehua Technology Park, No.63 Xintang Village, Fucheng Street,Longhua District,Shenzhen,Guangdong" to "4F & 5F, Building B, Nuofeng Technology Park, Yuzhang 5Rd, Da Shui Tian, LONGHUA DISTRICT, Shenzhen".
	Terry Lau	9.0	ML1 - 4	Revised ASSOCIATED MANUFACTURER's address "401 B Building, Shan Yuehua Technology Park, No.63 Xintang Village, Fucheng Street,Longhua District,Shenzhen,Guangdong" to "4F & 5F, Building B, Nuofeng Technology Park, Yuzhang 5Rd, Da Shui Tian, LONGHUA DISTRICT, Shenzhen".
			ML5	Added Multiple Listee 5 - "Super Bright LEDs, Inc."

12.0 Revision Summary							
The following changes are in compliance with the declaration of Section 8.1:							
Date/ Proj # Site ID	Project Handler/ Reviewer	Section	Item	Description of Change			
28-Oct-2022	Andy Tse	2.0	--	Revised models from "JXL-TZ04-T10W-5CCT, JXL-CM04-T10W-5CCT, JXL-TZ06-T12W-5CCT, JXL-CM06-T12W-5CCT, JXL-CA04-T10W-5CCT, JXL-CF04-T10W-5CCT, JXL-CA06-T12W-5CCT, JXL-CF06-T12W-5CCT, JXL-COB04-G12W-5CCT, JXL-TZ04-T10W-RGBCW, JXL-CA04-T10W-RGBCW, JXL-TZ06-T12W-RGBCW, JXL-CA06-T12W-RGBCW." to "JXL-TZ04-T10W-5CCT, JXL-CM04-T10W-5CCT, JXL-TZ06-T12W-5CCT, JXL-CM06-T12W-5CCT, JXL-CA04-T10W-5CCT, JXL-CF04-T10W-5CCT, JXL-CA06-T12W-5CCT, JXL-CF06-T12W-5CCT, JXL-COB04-G12W-5CCT, JXL-TZ04-T10W-RGBCW, JXL-CA04-T10W-RGBCW, JXL-TZ06-T12W-RGBCW or JXL-CA06-T12W-RGBCW; may be followed by -; may be followed by 27 to 65; may be followed by W, WH, MW, B, BL, BC, BK, WB, WHB, WBK, WBL, CM or OB."			
			--	Revised models from "JXL-TEH06-T18W-UDN may be followed by -; may be followed by 27 to 65." to "JXL-TEH06-T18W-UDN may be followed by -; may be followed by 27 to 65; may be followed by W, WH, MW, B, BL, BC, BK, WB, WHB, WBK, WBL, CM or OB."			
			--	Revised note 1b from "Suffix W, WH, MW, B, BL, BC, BK, WB, WHB, WBK, WBL or CM denotes finish color, for example, W or WH or MW for all white; B, BL, BC or BK for all black; WB, WHB, WBK or WBL for white with black, CM for Chrome." to "Suffix W, WH, MW, B, BL, BC, BK, WB, WHB, WBK, WBL, CM or OB denotes finish color, for example, W or WH or MW for all white; B, BL, BC or BK for all black; WB, WHB, WBK or WBL for white with black, CM for Chrome, OB for oil brown." in Model Similarity Table.			
			--	Added Alternative LED Driver "TR-319" for models JXL-TZ04-T10W-UDN-XX, JXL-TZ06-T12W-UDN-XX in Model Similarity Table..			
			--	Added Alternative LED Driver "TR-063" for models JXL-TZ04-T10W-5CCT, JXL-TZ06-T12W-5CCT, JXL-CA04-T10W-5CCT, JXL-CA06-T12W-5CCT in Model Similarity Table..			
			HK22090371 HKG	Terry Lau	3.0	176a-176b	Added photos for models JXL-TZ04-T10W-UDN-XX and JXL-TZ06-T12W-UDN-XX with Alternative LED driver of model TR-319
						176c	Added Alternative strain relief device for model JXL-TZ04-T10W-UDN-XX, JXL-TZ06-T12W-UDN-XX, JXL-TZ04-T10W-5CCT, JXL-TZ06-T12W-5CCT, JXL-CA04-T10W-5CCT and JXL-CA06-T12W-5CCT.
						274	Updated title. Added callouts# 155b, 155c.
						275	Updated title and photos. Added callouts# 168a.
						276	Updated title and photos. Removed callouts# 168a.
278a, 278b	Added photos for LED driver model TR-063.						
293-299	Added photos for LED driver model TR-319.						
4.0	86	Added photo# 176c.					

<b>12.0 Revision Summary</b>					
The following changes are in compliance with the declaration of Section 8.1:					
Date/ Proj # Site ID	Project Handler/ Reviewer	Section	Item	Description of Change	
	Cont'd	4.0	155b, 155c	Added components of Output wire, Material of connector.	
			166	Revised technical information from "secured on body by snap-fit." to "secured on body by snap-fit and a screw."	
			168	Removed photo# 276.	
			168a	Added components of Grounding wire-1.	
			172a	Added components of LED Driver-26.	
			173, 173a, 175, 176, 176a- 176g, 177, 178, 178a	Added photo# 278a.	
			179	Added photo# 278b.	
			206-219	Added components for alternative LED Driver-27 model TR-319.	
			5.0	172a, 212	Added CEC components for alternative LED Drivers.
			6.0	9	Updated Markings features.
				13	Updated Transformer features.
			7.0	1	Updated the table of Format Designation of Markings and Instructions.
				93a, 93b	Added illustrations for LED driver model TR-063.
				94	Updated title.
			99-101	Added illustrations for LED driver model TR-319.	
		8.0	--	Added test summary.	
		11.1	--	Added One sample from each shipment of Section 4.0 item 215.	

12.0 Revision Summary				
The following changes are in compliance with the declaration of Section 8.1:				
Date/ Proj # Site ID	Project Handler/ Reviewer	Section	Item	Description of Change
13-Feb-2023	Mike Wong  Digitally signed by Mike Wong Location: Intertek Testing Services Limited	2.0	--	Deleted model and revised from "JXL-CA03-T07W-UDD-, JXL-CF03-T07W-UDD-, JXL-TZ04-F10W-UDD-, JXL-TZ04-T10W-UDD-, JXL-TZ06-F12W-UDD-, JXL-TZ06-T12W-UDD-, JXL-TZ04-T10W-CCT -, JXL-TZ06-T12W-CCT -, JXL-DZ04-T10W-UDD- or JXL-DZ06-T12W-UDD-; followed by 27 to 65." to "JXL-TZ04-T10W-CCT - or JXL-TZ06-T12W-CCT -; followed by 27 to 65."
HK22120435 HKG	Terry Lau  Digitally signed by Terry Lau Location: Intertek Testing Services Limited		--	Deleted model and revised from "JXL-COB03-T07W-UDD, JXL-COB03-T10W-UDD, JXL-TD04-A10W-UDD, JXL-TD06-A12W-UDD, JXL-COB04-T10W-UDD, JXL-COF04-T10W-UDD, JXL-TZ06-T15W-UDD, JXL-CM06-T15W-UDD, JXL-TA08-T18W-UDD, JXL-TF08-T18W-UDD, JXL-TE04-T12W-UDD, JXL-TE06-T20W-UDD, JXL-AF04-T10W-UDD, JXL-AF06-T15W-UDD, JXL-ZF03-T07W-UDD, JXL-ZF04-T12W-UDD, JXL-CA08-T25W-UDD, JXL-CF08-T25W-UDD, JXL-COB04-E15W-UDD, JXL-TE06-T25W-CCT , JXL-TE08-T25W-CCT , JXL-COB06-F25/18/15W-UDD, JXL-COB08-F25/18/15W-UDD, JXL-TE06-E25/18/15W-UDD, JXL-TE08-E25/18/15W-UDD, JXL-COB08-F36W-UDD or JXL-TE08-E36W-UDD; may be followed by -; may be followed by one to two numbers; may be followed by K; may be followed by W, WH, MW, B, BL, BC or BK." to "JXL-COB03-T07W-UDD, JXL-COB03-T10W-UDD, JXL-COB04-T10W-UDD, JXL-COF04-T10W-UDD, JXL-AF04-T10W-UDD, JXL-AF06-T15W-UDD, JXL-ZF03-T07W-UDD, JXL-ZF04-T12W-UDD, JXL-CA08-T25W-UDD, JXL-CF08-T25W-UDD, JXL-COB04-E15W-UDD, JXL-TE06-T25W-CCT , JXL-TE08-T25W-CCT , JXL-COB06-F25/18/15W-UDD, JXL-COB08-F25/18/15W-UDD, JXL-TE06-E25/18/15W-UDD, JXL-TE08-E25/18/15W-UDD, JXL-COB08-F36W-UDD or JXL-TE08-E36W-UDD; may be followed by -; may be followed by one to two numbers; may be followed by K; may be followed by W, WH, MW, B, BL, BC or BK."

12.0 Revision Summary				
The following changes are in compliance with the declaration of Section 8.1:				
Date/ Proj # Site ID	Project Handler/ Reviewer	Section	Item	Description of Change
	Cont'd			Deleted model and revised from "JXL-COB02-R08W-UDN, JXL-COB02-S08W-UDN, JXL-COB04-R12W-UDN, JXL-COB04-S12W-UDN, JXL-COB04-S15W-UDN, JXL-COB04-R15W-UDN, JXL-SMD04-G10W-UDN, JXL-COB04-G10W-UDN, JXL-COB04-G10W-CCT, JXL-SMD04-G10W-CCT, JXL-TE04-T12W-UDN, JXL-TEH04-T12W-UDN, JXL-TE06-T20W-UDN, JXL-TE08-T25W-UDN, JXL-TE06-G12W-UDN, JXL-TE06-T12W-UDN, JXL-TE08-T18W-UDN, JXL-TX05-T10W-UDN, JXL-TX10-T18W-UDN, JXL-TXH10-T18W-UDN, JXL-TZ04-T10W-UDN, JXL-TZ06-T12W-UDN, JXL-CA04-T10W-UDN, JXL-CA06-T12W-UDN, JXL-TZ04-R10W-CCT, JXL-TZ06-R12W-CCT, JXL-COB04-R12W-CCT, JXL-COB04-S12W-CCT, JXL-TXH03-T10W-CCT, JXL-TXH05-T18W-CCT, JXL-COB04-R15W-CCT, JXL-COB04-S15W-CCT, JXL-COB02-R08W-CCT, JXL-COB02-S08W-CCT, JXL-CA04-T10W-CCT, JXL-CA06-T12W-CCT, JXL-CM06-T12W-CCT, JXL-CM04-T10W-CCT, JXL-CF04-T10W-CCT or JXL-CF06-T12W-CCT; may be followed by -; may be followed by 27 to 65; may be followed by -; may be followed by S, SM, B or BF; may be followed by W, WH, MW, B, BL, BC, BK, WB, WHB, WBK, WBL or CM." to "JXL-COB02-R08W-UDN, JXL-COB02-S08W-UDN, JXL-COB04-R12W-UDN, JXL-COB04-S12W-UDN, JXL-COB04-S15W-UDN, JXL-COB04-R15W-UDN, JXL-SMD04-G10W-UDN, JXL-COB04-G10W-UDN, JXL-COB04-G10W-CCT, JXL-SMD04-G10W-CCT, JXL-TE04-T12W-UDN, JXL-TEH04-T12W-UDN, JXL-TE06-G12W-UDN, JXL-TE06-T12W-UDN, JXL-TE08-T18W-UDN, JXL-TX05-T10W-UDN, JXL-TX10-T18W-UDN, JXL-TXH10-T18W-UDN, JXL-TZ04-T10W-UDN, JXL-TZ06-T12W-UDN, JXL-CA04-T10W-UDN, JXL-CA06-T12W-UDN, JXL-TZ04-R10W-CCT, JXL-TZ06-R12W-CCT, JXL-COB04-R12W-CCT, JXL-COB04-S12W-CCT, JXL-TXH03-T10W-CCT, JXL-TXH05-T18W-CCT, JXL-COB04-R15W-CCT, JXL-COB04-S15W-CCT, JXL-COB02-R08W-CCT, JXL-COB02-S08W-CCT, JXL-CA04-T10W-CCT, JXL-CA06-T12W-CCT, JXL-CM06-T12W-CCT, JXL-CM04-T10W-CCT, JXL-CF04-T10W-CCT or JXL-CF06-T12W-CCT; may be followed by -; may be followed by 27 to 65; may be followed by -; may be followed by S, SM, B or BF; may be followed by W, WH, MW, B, BL, BC, BK, WB, WHB, WBK, WBL or CM."
		2.0	--	Removed model JXL-CA03-T07W-UDD-xx, JXL-CF03-T07W-UDD-xx, JXL-TZ04-F10W-UDD-xx, JXL-TZ04-T10W-UDD-xx, JXL-TZ06-F12W-UDD-xx, JXL-TZ06-T12W-UDD-xx, JXL-DZ04-T10W-UDD-xx, JXL-DZ06-T12W-UDD-xx, JXL-TD04-A10W-UDD-xx, JXL-TD06-A12W-UDD-xx, JXL-TZ06-T15W-UDD-xx, JXL-CM06-T15W-UDD-xx, JXL-AF04-T10W-UDD-xx, JXL-AF06-T15W-UDD-xx, JXL-ZF04-T12W-UDD-xx, JXL-SMD04-G10W-UDN-XX, JXL-COB04-G10W-UDN-XX, JXL-TE06-G12W-UDN-XX, JXL-TE06-T12W-UDN-XX, JXL-TE08-T18W-UDN-XX, JXL-TXH03-T10W-CCT, JXL-TXH05-T18W-CCT in model similarity and ratings

12.0 Revision Summary				
The following changes are in compliance with the declaration of Section 8.1:				
Date/ Proj # Site ID	Project Handler/ Reviewer	Section	Item	Description of Change
	Cont'd	2.0	--	Deleted technical description of LED driver model TR-007A, TR-007B, TR017-B, TR-031B in model similarity and ratings.
			--	Added new models: JXL-COB02-R9W-5CCT, JXL-COB02-S9W-5CCT, JXL-COB04-R15W-5CCT, JXL-COB04-S15W-5CCT, JXL-COB04-R12W-5CCT, JXL-COB04-S12W-5CCT, JXL-COB06-R15W-5CCT, JXL-COB06-S15W-5CCT, JXL-TA08-T18W-5CCT, JXL-TF08-T18W-5CCT, JXL-TZ06-T15W-5CCT, JXL-CA06-T15W-5CCT, JXL-SMD04-G12W-5CCT, JXL-TXH05-T11W-5CCT, JXL-TXH10-T18W-5CCT, JXL-ZF03-T07W-5CCT, JXL-TZ03-T7W-5CCT, JXL-BK04-T10W-5CCT, JXL-BK06-T12W-5CCT or JXL-COB04-T10W-5CCT; may be followed by -; may be followed by 27 to 65; may be followed by W, WH, MW, B, BL, BC, BK, WB, WHB, WBK, WBL, CM or OB.
			--	Added model similarity and ratings for new models.
		3.0	1-5	Deleted photo 1-5 of model JXL-CA03-T07W-UDD-xx.
			6-10	Deleted photo 6-10 of model JXL-CF03-T07W-UDD-xx
			11a	Deleted model description JXL-CA03-T07W-UDD-xx, JXL-CF03-T07W-UDD-xx, JXL-ZF04-T12W-UDD-xx.
			12-13	Deleted photo 12-13 of model JXL-TZ04-F10W-UDD-xx, JXL-TZ04-T10W-UDD-xx, JXL-TZ06-F12W-UDD-xx, JXL-TZ06-T12W-UDD-xx
			14,14a	Delete model description JXL-TZ04-F10W-UDD-xx, JXL-TZ04-T10W-UDD-xx, JXL-TZ06-F12W-UDD-xx, JXL-TZ06-T12W-UDD-xx, JXL-TD04-A10W-UDD-xx, JXL-TD06-A12W-UDD-xx, JXL-AF04-T10W-UDD-xx, JXL-AF06-T15W-UDD-xx, JXL-TZ06-T15W-UDD-xx, JXL-CM06-T15W-UDD-xx, JXL-TA08-T18W-UDD-xx, JXL-TF08-T18W-UDD-xx
			15-17	Deleted photos of model JXL-TZ04-F10W-UDD-xx, JXL-TZ04-T10W-UDD-xx, JXL-TZ06-F12W-UDD-xx, JXL-TZ06-T12W-UDD-xx
			18	Deleted model description JXL-TZ04-F10W-UDD-xx, JXL-TZ06-F12W-UDD-xx, JXL-TD04-A10W-UDD-xx, JXL-TD06-A12W-UDD-xx, JXL-AF04-T10W-UDD-xx, JXL-ZF04-T12W-UDD-xx, JXL-ZF03-T07W-UDD-xx
			19	Deleted model description JXL-TZ04-F10W-UDD-xx, JXL-TZ06-F12W-UDD-xx, JXL-TD04-A10W-UDD-xx, JXL-TD06-A12W-UDD-xx, JXL-AF04-T10W-UDD-xx, JXL-ZF04-T12W-UDD-xx, JXL-ZF03-T07W-UDD-xx
			20,21	Deleted photo 20,21 of driver model TR017-B for model JXL-CA03-T07W-UDD-xx, JXL-CF03-T07W-UDD-xx, JXL-TZ04-T10W-UDD-xx, JXL-TZ06-T12W-UDD-xx
			28	Updated photo.
			30-38	Deleted photo 30-38 for model JXL-DZ06-T12W-UDD-xx, JXL-DZ04-T10W-UDD-xx
			47-53	Deleted photo 47-53 of model JXL-TD04-A10W-UDD-xx, JXL-TD06-A12W-UDD-xx
			60-69	Deleted photo 60-69 of model JXL-TZ06-T15W-UDD-xx, JXL-CM06-T15W-UDD-xx
			70-74	Deleted photo 70-74 of model JXL-TA08-T18W-UDD-xx
			75-79	Deleted photo 75-79 of model JXL-TF08-T18W-UDD-xx
		80-81	Deleted photo 80-81 of model JXL-TE04-T12W-UDD-xx	
		82-87a	Deleted photo 82-87a of model JXL-TE04-T12W-UDD-xx, JXL-TE06-T20W-UDN-XX	

12.0 Revision Summary				
The following changes are in compliance with the declaration of Section 8.1:				
Date/ Proj # Site ID	Project Handler/ Reviewer	Section	Item	Description of Change
	Cont'd	3.0	88-94	Deleted photo 88-94 of model JXL-AF04-T10W-UDD-xx, JXL-AF06-T15W-UDD-xx
			99-102	Deleted photo 99-102 of model JXL-ZF04-T12W-UDD-xx
			111-112	Deleted photo 111-112 of model JXL-TZ06-T15W-UDD-xx
			136,137	Deleted Driver PCB photo of model JXL-TZ06-T15W-UDD-xx x, JXL-CM06-T15W-UDD-xx, JXL-AF06-T15W-UDD-xx, JXL-ZF04-T12W-UDD-x, JXL-ZF03-T07W-UDD-xx, JXL-TA08-T18W-UDD-xx, JXL-TF08-T18W-UDD-xx, JXL-TE04-T12W-UDD-xx, JXL-TE06-T20W-UDD-xx
			151-154	Deleted model description JXL-SMD04-G10W-UDN-XX, updated photos
			155-158	Deleted model description JXL-COB04-G10W-UDN-XX, updated photos
			159,160	Deleted model description JXL-TE06-T20W-UDN-XX JXL-TE08-T25W-UDN-XX and updated photos.
			161	Deleted external view of JXL-TE06-T20W-UDN-XX, JXL-TE04-T12W-UDN-XX, JXL-TEH04-T12W-UDN-XX, JXL-TE08-T25W-UDN-XX
			162,162a	Deleted model description JXL-TE06-T20W-UDN-XX JXL-TE08-T25W-UDN-XX.
			163-166	Deleted photo 163-166 of model JXL-TE06-G12W-UDN-XX, JXL-TE06-T12W-UDN-XX, JXL-TE08-T18W-UDN-XX
			179-182	Deleted photo 179-182 of model JXL-TXH03-T10W-CCT, JXL-TXH05-T18W-CCT
			187-189	Deleted photo 187-189 of LED driver model TR-007A
			190, 191,193	Deleted LED driver model description TR-007B, TR-028A.
			197,198,200	Deleted photo 197,198,200 for LED Driver TR-028B
			199,199a	Deleted LED driver model description TR-031B
			201	Deleted photo 201 of LED Driver of TR-007A, TR-007B
			206	Deleted photo 206 of PCB assembly photo for driver TR-028A, TR-028B
			207a,208a	Deleted photo 207a,208a of LED Driver model TR-031B
			300-343	Added photos for new models.
			4.0	1-18, 22a,24-26,29,33, 38,43,45, 46,53,59-62,82,84-84c,85-91, 94,95,106a-106c,106f-115,122

12.0 Revision Summary				
The following changes are in compliance with the declaration of Section 8.1:				
Date/ Proj # Site ID	Project Handler/ Reviewer	Section	Item	Description of Change
	Cont'd	4.0	6b,20-22,22b,23 a, 40-42,56,57, 58,64,67-71a,96-97e,102-103e,106, 106e, 106h2,108	Deleted components due to deleted photos in section 3.0.
			220-264	Added components for new models.
		5.0	71,71a,97d,97e,103d,103e,106e,	Deleted unlisted components.
			246,253,258	Added unlisted components for new models.
		6.0	8	Added schematics requirements.
			9	Added marking system requirement for new models.
			12	Added Transformer requirements for new models.
		7.0	3,6,7,17,18,19	Deleted model description of JXL-CA03-T07W-UDD-xx, JXL-CF03-T07W-UDD-xx, JXL-TZ04-F10W-UDD-xx, JXL-TZ04-T10W-UDD-xx, JXL-TZ06-F12W-UDD-xx, JXL-TZ06-T12W-UDD-xx, JXL-TD04-A10W-UDD-xx, JXL-TD06-A12W-UDD-xx, JXL-ZF04-T10W-UDD-xx, JXL-AF04-T12W-UDD-xx, JXL-ZF03-T07W-UDD-xx
			5	Deleted Illustration 5 - Schematics of driver PCB of models JXL-DZ04-T10W-UDD-xx and JXL-DZ06-T12W-UDD-xx
			10	Deleted Illustration 10 - Top PCB layout of driver of models JXL-DZ04-T10W-UDD-xx and JXL-DZ06-T12W-UDD-xx
			11,12	Deleted model description of JXL-TZ04-F10W-UDD-xx, JXL-TZ06-F12W-UDD-xx, JXL-TD04-A10W-UDD-xx, JXL-TD06-A12W-UDD-xx, JXL-ZF04-T10W-UDD-xx, JXL-AF04-T12W-UDD-xx, JXL-ZF03-T07W-UDD-xx
			22	Deleted Illustration 22 - Component difference table for driver model TR017-A and TR017-B
			23	Deleted Illustration 23 - Circuit of driver of models JXL-TZ06-T15W-UDD-xx, JXL-CM06-T15W-UDD-xx, JXL-TA08-T18W-UDD-xx, JXL-TF08-T18W-UDD-xx, JXL-TE04-T12W-UDD-xx, JXL-TE06-T20W-UDD-xx, JXL-AF06-T15W-UDD-xx.
			26	Illustration 26 - Top of PCB layout of driver of models JXL-TZ06-T15W-UDD-xx, JXL-CM06-T15W-UDD-xx, JXL-TA08-T18W-UDD-xx, JXL-TF08-T18W-UDD-xx, JXL-TE04-T12W-UDD-xx, JXL-TE06-T20W-UDD-xx, JXL-AF06-T15W-UDD-xx.
		27	Illustration 27 - Bottom of PCB layout of driver of models JXL-TZ06-T15W-UDD-xx, JXL-CM06-T15W-UDD-xx, JXL-TA08-T18W-UDD-xx, JXL-TF08-T18W-UDD-xx, JXL-TE04-T12W-UDD-xx, JXL-TE06-T20W-UDD-xx, JXL-AF06-T15W-UDD-xx.	

12.0 Revision Summary				
The following changes are in compliance with the declaration of Section 8.1:				
Date/ Proj # Site ID	Project Handler/ Reviewer	Section	Item	Description of Change
	Cont'd		32	Deleted Illustration 32 - Specification of inductor(L1) for models JXL-TZ06-T15W-UDD-xx, JXL-CM06-T15W-UDD-xx, JXL-TA08-T18W-UDD-xx, JXL-TF08-T18W-UDD-xx, JXL-TE04-T12W-UDD-xx, JXL-TE06-T20W-UDD-xx, JXL-AF06-T15W-UDD-xx.
			34	Deleted Illustration 34 - Specification of inductor(LF1) for models JXL-TZ06-T15W-UDD-xx, JXL-CM06-T15W-UDD-xx, JXL-TA08-T18W-UDD-xx, JXL-TF08-T18W-UDD-xx, JXL-TE04-T12W-UDD-xx, JXL-TE06-T20W-UDD-xx, JXL-AF06-T15W-UDD-xx.
			36	Deleted Illustration 36 - Specification of inductor(LF2) for models JXL-TZ06-T15W-UDD-xx, JXL-CM06-T15W-UDD-xx, JXL-TA08-T18W-UDD-xx, JXL-TF08-T18W-UDD-xx, JXL-TE04-T12W-UDD-xx, JXL-TE06-T20W-UDD-xx, JXL-AF06-T15W-UDD-xx.
			38	Deleted Illustration 38 - Specification of transformer(T1) of TR018A for models JXL-TZ06-T15W-UDD-xx, JXL-CM06-T15W-UDD-xx, JXL-TA08-T18W-UDD-xx, JXL-TF08-T18W-UDD-xx, JXL-TE04-T12W-UDD-xx, JXL-TE06-T20W-UDD-xx, JXL-AF06-T15W-UDD-xx.
			39	Deleted Illustration 39 - Specification of transformer(T1) of TR018A for models JXL-TZ06-T15W-UDD-xx, JXL-CM06-T15W-UDD-xx, JXL-TA08-T18W-UDD-xx, JXL-TF08-T18W-UDD-xx, JXL-TE04-T12W-UDD-xx, JXL-TE06-T20W-UDD-xx, JXL-AF06-T15W-UDD-xx.
			42	Deleted Illustration 42 - Specification of transformer(T1) of TR018C for models JXL-TE04-T12W-UDD-xx
			43	Deleted Illustration 43 - Specification of transformer(T1) of TR018C for models JXL-TE04-T12W-UDD-xx
		7.0	50	Deleted model description of JXL-SMD04-G10W-UDN-XX, JXL-TE06-G12W-UDN-XX, JXL-TE06-T12W-UDN-XX, JXL-TE08-T18W-UDN-XX, JXL-TXH03-T10W-CCT, JXL-TXH05-T18W-CCT, JXL-COB04-G10W-UDN-XX, JXL-TE06-T20W-UDN-XX, JXL-TE08-T25W-UDN-XX
			51	Deleted model description of JXL-COB02-R08W-UDN-XX, JXL-COB02-S08W-UDN-XX, JXL-COB04-R12W-UDN-XX, JXL-COB04-S12W-UDN-XX, JXL-SMD04-G10W-UDN-XX, JXL-COB04-G10W-UDN-XX, JXL-TE06-G12W-UDN-XX, JXL-TE06-T12W-UDN-XX, JXL-TZ04-T10W-UDN-XX, JXL-TZ06-T12W-UDN-XX, JXL-CA04-T10W-UDN-XX, JXL-CA06-T12W-UDN-XX, JXL-TXH05-T18W-CCT, JXL-TE08-T18W-UDN-XX, JXL-TXH03-T10W-CCT, JXL-SMD04-G10W-UDN-XX, JXL-COB04-G10W-UDN-XX, JXL-TE06-G12W-UDN-XX, JXL-TE06-T20W-UDN-XX, JXL-TE08-T25W-UDN-XX
			52	Deleted Illustration 52 - Circuit diagram for model TR-007A and TR-007B
			53	Deleted Illustration 53 - PCB Layout diagram for model TR-007A and TR-007B
			54	Deleted Illustration 54 - Transformer T1 Specification for model TR-007A .
			55	Deleted Illustration 55 - Transformer T1 Specification for model TR-007A .
			56	Deleted Illustration 56 - Transformer T1 Specification for model TR-007B .
			57	Deleted Illustration 57 - Transformer T1 Specification for model TR-007B .

